

RAILROAD DESIGN
AND REHABILITATION

APPROVED FOR PUBLIC RELEASE: DISTRIBUTION IS UNLIMITED

REPRODUCTION AUTHORIZATION/RESTRICTIONS

This manual has been prepared by or for the Government and is public property and not subject to copyright.

Reprints or republications of this manual should include a credit 4 substantially as follows: "Joint Departments of the Army and Air -Force, TM 5-850-2/AFMAN 321046, Railroad Design and Rehabilitation, 16 October 1995."

TECHNICAL MANUAL }
No. 5-850-2 }
AIR FORCE MANUAL }
No. 32-1046 }

HEADQUARTERS
DEPARTMENTS OF THE ARMY
AND AIR FORCE
WASHINGTON, DC, 16 October 1995

RAILROAD DESIGN AND REHABILITATION

CHAPTER		<i>Paragraph</i>	<i>Page</i>
1.	GENERAL INFORMATION		
	Purpose	1-1	1-1
	Scope	1-2	1-1
	References	1-3	1-1
	Organization and Use of the Manual	1-4	1-1
	Supplementary Material	1-5	1-1
	Using the AREA Manual for Railway Engineering	1-6	1-1
	Applicability of State and Commercial Railroad Standards	1-7	1-2
	Sources of Assistance	1-8	1-2
2.	DETERMINING TRAFFIC AND LOAD CARRYING REQUIREMENTS		
	Introduction	2-1	2-1
	Traffic Type	2-2	2-1
	Traffic Volume	2-3	2-1
	Wheel Loads	2-4	2-1
	Locomotive Tractive Effort	2-5	2-1
	Traffic and Terminals	2-6	2-2
	Sources for Traffic Information	2-7	2-2
3.	ESTABLISHING ROUTE PROFILE AND ALIGNMENT SPECIFICATIONS		
	Introduction	3-1	3-1
	Grades and Grade Resistance	3-2	3-1
	Route Profile and Transitions Between Grades	3-3	3-1
	Curvature, Curve Resistance, and Effective Grade	3-4	3-1
	Locomotive Tonnage Rating	3-5	3-3
	Trial Ruling Grade	3-6	3-3
4.	ROUTE SELECTION		
	Introduction	4-1	4-1
	Establishing Control Points and Potential Corridors	4-2	4-1
	Reconnaissance	4-3	4-1
	Initial Survey	4-4	4-2
	Trial Location	4-5	4-2
	Final Location	4-6	4-3
5.	REHABILITATION: TRACK, BRIDGES, AND TERMINALS		
	Definition and Application	5-1	5-1
	Installation Requirements and Facility Evaluation	5-2	5-1
	Condition Evaluation	5-3	5-1
	Structural Evaluation	5-4	5-2
	Operational Evaluation	5-5	5-2
	The Rehabilitation Plan	5-6	5-2
	Final Plans and Specifications	5-7	5-3
	Construction and On-Site Inspection	5-8	5-4
6.	STRUCTURAL DESIGN		
	Track Structure	6-1	6-1
	Track Design Methods	6-2	6-1
	AREA Design Procedure (Modified)	6-3	6-1
	Roadway	6-4	6-6
	Subgrade	6-5	6-6
	Frost Design Modifications	6-6	6-10
	Drainage	6-7	6-14
	Geotextiles	6-8	6-15
	Ballast	6-9	6-16
	Sub-Ballast	6-10	6-17
	Ties and Tie Spacing	6-11	6-18
	Rail	6-12	6-19
	Other Track Material	6-13	6-21

*This manual supersedes TM 5-850-2/AFM 88-7, Chap. 2, dated 1 July 1980

	<i>Paragraph</i>	<i>Page</i>
Turnouts and Crossovers	6-14	6-24
Road Crossings	6-15	6-28
Rail Crossings	6-16	6-36
Bridges	6-17	6-37
Miscellaneous Track Appliances	6-18	6-40
7. GEOMETRIC DESIGN		
Roadway Cross Section	7-1	7-1
Grades and Track Profile	7-2	7-1
Horizontal Curves	7-3	7-1
Turnouts	7-4	7-2
Track Connections and Ladder Tracks	7-5	7-4
Clearances	7-6	7-4
Road Crossings	7-7	7-6
8. TERMINALS		
Introduction	8-1	8-1
Siting and General Layout	8-2	8-1
Track Design	8-3	8-1
Clearances and Usable Track Length	8-4	8-2
Vehicle Terminals	8-5	8-2
Break Bulk (Small Cargo) Terminals	8-6	8-7
Container Terminals	8-7	8-7
Ammunition Terminals	8-8	8-9
POL Terminals	8-9	8-9
Car Interchange	8-10	8-9
Yard, Storage, and Other Auxiliary Tracks	8-11	8-11
Miscellaneous Buildings	8-12	8-13
Security Fencing	8-13	8-13
9. CONSTRUCTION		
Construction Survey	9-1	9-1
Inspecting Materials	9-2	9-1
Saving Salvageable Materials	9-3	9-1
Subgrade and Drainage	9-4	9-1
Track Construction	9-5	9-1
Quality Control/Quality Assurance	9-6	9-3
As-Built and Final Drawings	9-7	9-3
APPENDIX A. REFERENCES		A-1
B. RULING GRADE-EXAMPLE PROBLEM		B-1
C. TRACK (1.0): TRACK DESIGN AND EVALUATION FOR WORK PLANNING AND BUDGETING-DESCRIPTION AND EXAMPLE		C-1
D. EXAMPLE TRACK REHABILITATION REPORT		D-1

List of Figures

	<i>Page</i>
2-1. Common Freight Cars	2-3
3-1. Combining Curves	3-2
6-1. Example load distribution along the track	6-2
6-2. Example vertical pressure reduction through the track	6-3
6-3. Relationship between maximum track deflection and long term track performance	6-4
6-4. Design wheel configurations	6-5
6-5. Typical cross section-tangent track	6-7
6-6. Typical cross section with subballast layer-tangent track	6-7
6-7. Typical cross section-curved track	6-8
6-8. Typical cross section with subballast layer-curved track	6-8
6-9. Typical cross section-track with adjacent service road	6-9
6-10. Typical cross section-track with geotextile	6-9
6-11. Typical cross section with subballast layer-track with geotextile	6-10
6-12. General method for determining the frost susceptibility of soils	6-11
6-13. Design air freezing indexes in North America	6-12
6-14. Air freezing index/Surface cover/Frost penetration relationship	6-13
6-15. Required subdrainage where surrounding natural ground is above bottom of ballast and open side ditches cannot be installed	6-15
6-16. Geotextile installation under a turnout	6-16
6-17. Geotextile installation at a bridge abutment	6-16
6-18. Anti-Splitting Devices for Tie Ends	6-18

	<i>Page</i>
6-19.	Tie Plates 6-22
6-20.	Recommended Minimum Rail Anchor Application 6-23
6-21.	Rail Anchors 6-24
6-22.	Rail Anchor Applications at Open Deck Bridges and Rail Crossings 6-25
6-23.	General Arrangement of Turnouts and Crossovers 6-26
6-24.	Parts of a Turnout 6-27
6-25.	Typical Type 1A Gravel Crossing 6-30
6-26.	Typical Type 1B Gravel Crossing 6-31
6-27.	Typical Type 2 Timber Crossing 6-32
6-28.	Typical Type 3 Asphalt Crossing 6-33
6-29.	Typical Type 4A Cast-in-Place Concrete Crossing 6-34
6-30.	Typical Type 4B Prefabricated Concrete Crossing 6-35
6-31.	Typical Type 5 Elastomeric (Rubber) Crossings 6-36
6-32.	Typical Geotextile/Subdrain Installation for Road Crossings 6-37
6-33.	Typical Drainage at Road Crossings 6-38
6-34.	Recommended Track Construction for Road Crossings 6-39
6-35.	Clear Crossing Visibility Area for Approaching Vehicles 6-40
6-36.	Clear Crossing Visibility Area for Stopped Vehicles 6-41
6-37.	Cooper Loading Configuration for Bridges 6-43
6-38.	Variation in Cooper E Value with Span Length 6-44
6-39.	Loading Diagram for Train of 100-Ton Boxcars 6-45
6-40.	Location of Derails 6-47
7-1.	Determining Frog Number (Turnout Size) 7-3
7-2.	Turnout Design 7-4
7-3.	Diverging Route Connection 7-5
7-4.	Parallel Siding Connection 7-6
7-5.	Ladder Track Layout 7-7
7-6.	Clearance Diagram for Tangent Track 7-8
7-7.	Location of Clearance Points 7-10
8-1.	Typical Small Yard with Storm Drainage 8-2
8-2.	Vehicle Terminal 8-4
8-3.	Track and Approach Road Lengths for Vehicle Loading 8-5
8-4.	Concrete End Ramp 8-6
8-5.	Portable Multilevel Ramp 8-7
8-6.	Concrete Side Ramp 8-8
8-7.	Interchange Yard 8-10
8-8.	Auxiliary Tracks 8-12
C-1.	Main Menu for TRACK(1.0) C-2
C-2.	Tie Decay Hazard Map of the U S C-3
C-3.	Report from TRACK(1.0) C-3
D-1.	Track Diagram for Fort Example D-6

List of Tables

	<i>Page</i>
2-1.	Common Cargo Types and Loading Requirements 2-2
2-2.	Common Car Types and Design Wheel Loads 2-4
3-1.	Grade Design Categories for Main Running Tracks 3-1
3-2.	Recommended Minimum Grade Lengths 3-1
3-3.	Curve Design Categories for Main Running Tracks 3-2
3-4.	Curve Compensation for a 1% Grade 3-2
3-5.	Estimating Locomotive Traction Effort 3-3
3-6.	Design Gross Car Weights 3-3
6-1.	Suggested Design Track Modulus Values 6-5
6-2.	Rail Sections 6-5
6-3.	Recommended Ballast Gradations 6-17
6-4.	Dimension and Surface Specifications for Relay (Secondhand) Rail 6-20
6-5.	Switch Ties for Standard Turnouts 6-28
6-6.	Recommended Crossing Surfaces 6-29
6-7.	Clear Visibility Distances at Road Crossings 6-42
6-8.	Recommended Cooper Design Load for Bridges 6-46
7-1.	Recommended Transition Rates Between Grades on Main Running Tracks 7-1
7-2.	Design Superelevation for Curved Track 7-2
7-3.	Turnout Size Selection Criteria 7-3
7-4.	Overhead and Side Clearances for Tangent Track 7-9

	<i>Page</i>
9-1. Suggested Stake Intervals for Final Survey	9-1
9-2. Rail Joint Gap	9-2
B-1. Curve Compensation for 1.16% Grade	B-1
C-1. Add 6" Ballast to Track	C-5
C-2. Add 6" Ballast and Install 115 lb Rail	C-5
C-3. Add 6" Ballast and Install 7" x 9" Ties	C-5
D-1. Key to Track Names and Station Locations	D-7
D-2. Cost Estimate Summary	D-10
D-3. Road Crossing Repair/Rebuilding	D-11
D-4. Turnout Rehabilitation	D-13
D-5. Ballast and Surfacing Locations	D-14

CHAPTER 1

GENERAL INFORMATION

1-1. Purpose.

This manual provides guidance for design and rehabilitation of railroad track, terminals, and loading facilities, including information related to construction.

1-2. Scope.

a. The guidance in this manual is primarily for railroad lines operated at lower speeds and with lower traffic volumes than those most commonly found in the commercial industry. The guidance on terminal design is for small terminals handling military cargo: primarily tracked or wheeled vehicles and intermodal containers.

b. This manual, supplemented with the specified references, should provide sufficient information for general purposes. Most projects, however, include some aspects that are very site-specific or some conditions which are not common. Designers are encouraged to obtain assistance when unusual or unfamiliar situations are encountered.

1-3. References.

Appendix A contains a list of references used in this manual.

1-4. Organization and Use of the Manual.

a. *Applying the material in this manual.* Designing a railroad involves satisfying many objectives, which often conflict. Throughout the process the designer must prioritize project objectives and decide to what extent one objective may be sacrificed to satisfy another. It is the proper balance of these compromises, specifically matched to each situation, which produces a good railroad design.

b. *New lines and terminals.* For designing new railroad lines and terminals, chapters 2 through 4 and 6 through 8 of this manual are required. The design process is summarized in these steps:

(1) Determine the traffic and load carrying requirements-estimate the number of cars to be handled over the line and the magnitude of the wheel loads the track must support.

(2) Determine the terminal and support facilities requirements-from the type and magnitude of traffic to be handled, determine the number, size, and location of loading and unloading facilities (terminals), sidings, wyes, and other support facilities and auxiliary tracks.

(3) Establish route profile and alignment guidelines-based on load carrying requirements,

maximum desired speed, locomotive pulling capability, and other operating needs and conditions, select maximum effective grade, horizontal and vertical curvature, and other profile and alignment specifications.

(4) Select the route-through an iterative process, select the best route and profile between the terminals and the connecting commercial carrier (usually the nearest commercial railroad line).

(5) Design the track, roadway, and terminal and support facilities-from the traffic and wheel load estimates and the characteristics of the selected route, determine track, roadway, and drainage requirements.

c. *Rehabilitation.* For rehabilitating existing lines and facilities, chapters 5 through 8 are required, along with portions of chapter 2.

1-5. Supplementary Material.

Listed below are references and other material which are generally required for railroad design and rehabilitation. Full citation of references is given in appendix A:

(1) AREA Manual for Railway Engineering and Portfolio of Trackwork Plans.

(2) Installation Transportation System Capability Study.

(3) Drainage design guides.

(4) Railroad Track Standards (TM 5-628/AFR 91-44).

(5) Detailed maps (including contour maps) of the area through which the railroad will run.

1-6. Using the Area Manual for Railway Engineering.

a. The American Railway Engineering Association's Manual for Railway Engineering is a standard industry reference and is cited throughout this technical manual. It contains a wide range of guidance to cover a variety of needs, with emphasis on commercial lines carrying substantial freight traffic. As a broad range of specifications is often given, proper use of the AREA manual requires that the designer select the particular specifications which are most appropriate for a particular project.

b. The AREA manual is written primarily for the commercial carriers, which have their own company policies and procedures. The material was prepared with the assumption that many details need not be covered, as a company's own

practices would govern. Therefore, it is usually necessary for military designers to provide details above and beyond the material contained in the AREA manual. In addition, requirements for operation on military railroads may sometimes differ from those commonly found on commercial carriers. In these cases, the design guidance in this technical manual may vary from that found in the AREA manual.

c. For these reasons, when preparing designs and specifications, the use of general statements such as ". meeting AREA specifications" should be avoided. Such statements often leave the choice of materials or procedures wide open and can lead to an undesirable or unsatisfactory product. Designers should clearly specify the work to be done and the acceptable materials for use in construction.

1-7. Applicability of State and Commercial Railroad Standards.

a. States often have standards, particularly for clearances, which should be met during new construction or rehabilitation. These standards may

be obtained from the appropriate state departments of transportation and public utilities.

b. In addition, designers should assure that any new or rehabilitated track which will be regularly operated over by a commercial railroad will be in compliance with their track requirements.

1-8. Sources of Assistance.

a. Designers are encouraged to call for assistance when questions arise on the best choice to lit a particular situation or for further interpretation of material in this technical manual or other references. Assistance may be obtained rough the Army Transportation Systems Mandatory Center, Missouri River Division, Omaha, E (CEMRD-ED-TT) or Air Force HQ FCESA/ENC.

b. Particularly for installations which depend on the connecting commercial carrier for service, either for routine traffic or only during a mobilization, that carrier should be consulted at least bout the arrangement of the interchange yard and preferably for other suggestions on track arrangement to promote more convenient service.

CHAPTER 2

DETERMINING TRAFFIC AND LOAD CARRYING REQUIREMENTS

2-1. Introduction.

a. The first step in designing a railroad is to determine the type and volume of traffic to be handled. Traffic type and volume will generally govern the size and arrangement of terminal facilities, the number of auxiliary tracks required, and track structure design.

b. The traffic handling capability at an installation must cover existing and foreseeable requirements, which usually include:

- (1) Mobilization outloading.
- (2) Training exercises.
- (3) Installation supply (routine traffic).

c. Once assembled, data on traffic volume and type should be reviewed and approved before proceeding with the design process.

2-2. Traffic Type.

Information gathered on traffic type should include:

- a. Type of cargo to be handled.
- b. Type and size of freight cars to be used.
- c. Manner in which cargo will be loaded and unloaded.
- d. Height and width of cargo (for clearance requirements) handled on open cars (flatcars and gondolas).
- e. Special requirements or restrictions for loading, unloading, or moving the cargo (especially when handling hazardous cargo). From this information the required type of loading facilities can be determined. Planning and design for loading facilities are covered in chapter 9. Table 2-1 lists the most common cargo types along with the freight cars and loading facilities usually required to handle the cargo. Common freight car types are illustrated in figure 2-1.

2-3. Traffic Volume.

In addition to the type of traffic, the amount of traffic must also be estimated. This information should include:

- a. Maximum number of cars (for each traffic type) that might be on the installation at any one time, including empty cars.
- b. Longest train that needs to be accommodated into or out of the installation.
- c. Maximum number of cars (of all types) that might be on the installation at any one time, including empty cars.

d. Maximum number of cars that each loading facility or terminal area might be required to handle in a single loading or unloading cycle.

2-4. Wheel Loads.

a. Track structure design is greatly influenced by the magnitude of the wheel loads that the track must support. While many different types of cars and loadings may be handled aboard an installation, for planning purposes the design wheel load is based on the heaviest type of loaded car that will most commonly run over a particular track.

b. In many cases, the wheel loads from an engine (either Army-owned or from the commercial carrier) will represent the heaviest single load on the track. However, the number of wheels from loaded cars will typically far exceed the number of locomotive wheels over much of the track, and therefore, it is the magnitude of the car wheel load that should govern in most cases. In either case, both loading conditions must be checked before final design.

c. The design wheel load is usually obtained by taking the static wheel load for the heaviest commonly used car and adding a factor to account for the dynamic affects of travel speed combined with track and wheel irregularities.

d. Table 2-2 lists suggested design wheel loads for planning purposes. To use the table, select the car type in the first column which most closely matches the heaviest car in common use over the track. For terminal areas and around an installation, where speeds will usually be limited to 10 MPH, select the design wheel load in the column labeled "10 MPH or Less." For track connecting the installation with the commercial carrier where train speed will likely exceed 10 MPH, use the column labeled "More Than 10 MPH." For track mostly used by an engine during switching, or where mostly empty cars will be stored, or which will otherwise see only occasional use, select from the column labeled "Light Use."

2-5. Locomotive Tractive Effort.

a. *Definition.* When designing a railroad route, it is necessary to know how much pulling force a locomotive is capable of exerting. This pulling force is known as tractive effort. Tractive effort is maximum at starting and diminishes as speed increases.

b. *Application.* Locomotive tractive effort, along with the route gradient and curvature, will largely

Table 2-1. Common Cargo Types and Loading Requirements.

CARGO	CAR TYPE	LOADING/UNLOADING METHOD	FACILITY REQUIRED
Light Wheel (0.25T - 2.5T)	Auto Racks Bi/Tri-level	Circus-type loading/unloading - staging area and spanner boards are required.	Multi-level End Ramp
Heavy Wheel 15.0T - HET)	Flatcar (40T - 140T)	Circus-type loading/unloading - staging area and spanner boards are required.	Permanent/Portable End Ramp
Light Track (APC, Bradley)	Flatcar (40T - 140T)	Circus-type loading/unloading - staging area and spanner boards are required.	Permanent End Ramp
Heavy Track (Tank: M1, M60)	Flatcar 140T	Circus-type loading/unloading - staging area and spanner boards are required.	Permanent End Ramp
Engineer Equipment (Wheel & Track)	Flatcar (40T - 140T)	Special load items- crane access next to track may be required. Spanner boards are needed.	Permanent End Ramp
40' Container	COFC	Crane w/spreader bar or RTCH and yard tractor/trailer tandems.	Container Loading Facility
20' Container	COFC	Crane w/spreader bar or RTCH and yard tractor/trailer tandems.	Container Loading Facility
Conex	Flatcar Gondola	Crane loading/unloading - crane access required next to track.	None
POL (Bulk)	Tankcar	Pumping or dumping through a pipe network.	POL Handling facility equipped with spill containment.
POL (Palletized)	Boxcar	Forklift into warehouse or dock, staging area next to dock may be required.	Side loading ramp equipped with spill containment.
POL (containerized)	COFC	Crane w/spreader bar or RTCH and yard tractor/trailer tandems.	Container loading facility equipped w/spill containment.
Ammunition (Palletized)	Boxcar	Forklift onto dock, staging area needed next to dock.	Side loading ramp and meet the Q-D requirements.
Ammunition (containerized)	COFC	Crane w/spreader bar or RTCH and yard tractor/trailer tandems.	Container loading facility that meets Q-D requirements.
Miscellaneous breakbulk	Boxcar	Forklift onto side loading ramp, staging area needed next to dock.	Side loading ramps.

determine how many cars can be pulled over the route in a single train. From another perspective, locomotive tractive effort and minimum desired train size may determine the maximum grade and curvature tolerable on a given route.

c. *Tractive Effort Data.* Tractive effort data (or graphs) are often available for both military and commercial locomotives. When not readily obtainable, the data can be estimated from the locomotive weight and engine horsepower rating. This procedure is covered in paragraph 3-6.

2-6. Traffic and Terminals.

Once the traffic handling requirements have been identified, as described in paragraphs 2-1 to 2-3,

the process of designing the terminal and support facilities can begin. The number and size (or length) of the required facilities and serving trackage is based on these traffic requirements. Chapter 8 covers planning and design for terminals.

2-7. Sources for Traffic Information.

Information about traffic types, car types, and volume, and mobilization requirements should be obtained from the Installation Transportation Officer (ITO) and from the installation Transportation System Capability Study prepared by the Transportation Engineering Agency of the Military Traffic Management Command (MTTE-SEF).

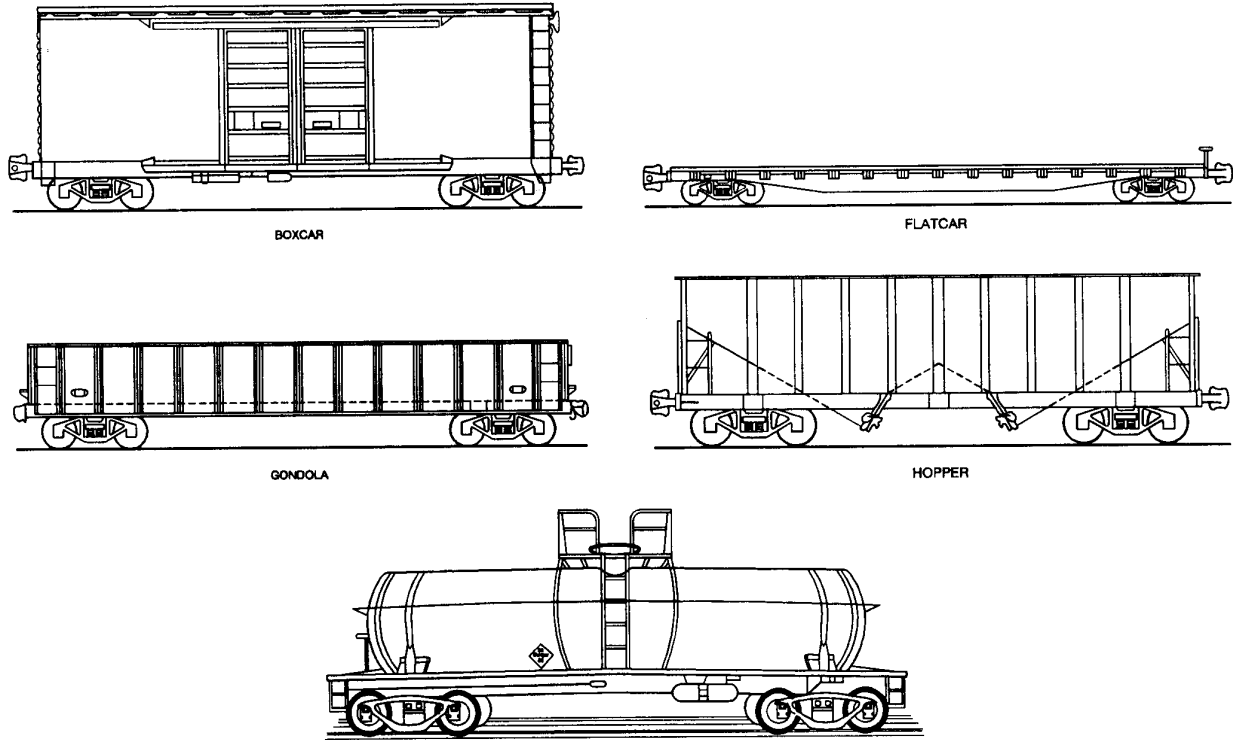

Figure 2-1. Common Freight Cars.

Table 2-2. Common Car apes and Design Wheel Loads.

Most Common Heavy Car	Design Wheel Load		
	10-25 MPH	<= 10MPH I	Light Use
Box, 40 T	20,000 lbs	17,600 lbs	16,000 lbs
Box, 50 T	26,250 lbs	23,100 lbs	21,000 lbs
Box, 70T	34,500 lbs	30,250 lbs	27,500 lbs
Flat, 40 T	17,500 lbs	15,400 lbs	14,000 lbs
Flat, 50 T	23,750 lbs	20,900 lbs	19,000 lbs
Flat, 80 T (6-axle)	23,750 lbs	20,900 lbs	19,000 lbs
Flat, 100 T (6-axle)	32,500 lbs	28,600 lbs	26,000 lbs
Flat, 140 T (6-axle)	38,750 lbs	34,100 lbs	31,000 lbs
COFC, 70 T	30,000 lbs	26,400 lbs	24,000 lbs
TOFC, 70 T	30,000 lbs	26,400 lbs	24,000 lbs
Gondola, 40 T High Side	18,750 lbs	16,500 lbs	15,000 lbs
Gondola, 50 T High Side	22,500 lbs	19,800 lbs	18,000 lbs
Gondola, 50 T Low Side	22,500 lbs	19,800 lbs	18,000 lbs
Tank, 7500 Gallon	16,250 lbs	14,300 lbs	13,000 lbs
Tank, 10000 Gallon	22,500 lbs	19,800 lbs	18,000 lbs
Tank, 20000 Gallon	36,250 lbs	31,900 lbs	29,000 lbs
Hopper, 50 T	21,250 lbs	18,700 lbs	17,000 lbs
Hopper, 70 T	30,000 lbs	26,400 lbs	24,000 lbs
Locomotive, EMD 120 T (6-axle)	25,000 lbs	22,000 lbs	20,000 lbs
Locomotive, EMD GP-7 or 9	37,500 lbs	33,000 lbs	30,000 lbs
Locomotive, EMD SW-8	31,250 lbs	27,500 lbs	25,000 lbs
Locomotive, DAV-BES 80 T	25,000 lbs	22,000 lbs	20,000 lbs
Locomotive, GE 65 T	20,000 lbs	17,600 lbs	16,000 lbs
Locomotive, GE 40 T	13,750 lbs	12,100 lbs	11,000 lbs
Locomotive, GE 25 T	15,600 lbs	13,800 lbs	12,500 lbs

CHAPTER 3

ESTABLISHING ROUTE PROFILE AND ALIGNMENT SPECIFICATIONS

3-1. Introduction.

a. The procedures outlined in this chapter (along with information on locomotive propulsion force, desired train capacity, propulsion resistances, and train operating requirements) can be used to select the maximum grade and curvature and minimum transitions between grades and reverse curves.

b. Initially, these specifications should be treated only as guidelines, as analyses of route topography may require changes to keep construction costs within acceptable limits. Typically, the information and procedures described in this chapter will be used iteratively with those in chapter 4 until a suitable compromise is reached.

c. In appendix B, a sample problem illustrates the determination of a ruling grade.

d. The specifications listed in this chapter are primarily for main running tracks. Additional profile and alignment specifications for terminal areas are given in chapter 8. Details on field layout of horizontal and vertical curves are given in chapter 7.

3-2. Grades and Grade Resistance.

a. *Definition.* Railroad grades are designated by the amount of elevation change in 100 feet of length, expressed in percent. The additional force required to move a train, due to the presence of a grade, is known as grade resistance. Grade resistance equals 20 pounds for each ton of train weight and percent of grade. Thus, it takes twice the force to pull a train up a 2% grade as it does a 1% grade. For this reason, the choice of maximum gradient (the rate of elevation change on a particular grade) can have a great effect on operations over a route.

b. *Ruling Grade.* When a particular grade limits train size (tonnage) and speed over a route, that grade is known as the ruling grade. The ruling grade is not always the steepest grade, as a train's momentum may help carry it over a grade steeper, but shorter, than the ruling grade.

c. *Grade Design Categories.* Grade design categories for main running tracks are shown in table 3-1.

3-3. Route Profile and Transitions Between Grades.

a. *Profile and Grade Length.* A route's profile is characterized by the steepness of grades and

changes in grade along the route. Train operations are enhanced by avoiding frequent changes between ascending and descending grades (a rolling profile). Route design and construction are often simplified by avoiding frequent changes in grade steepness. Table 3-2 shows recommended minimum grade lengths.

b. *Transitions between grades.:*

(1) Transitions between grades are made with vertical curves. These transitions are necessary for smooth train operation, but they increase the amount of surveying and staking required and are more difficult to construct than uniform grades.

(2) Design guidance for grade transitions is given in paragraph 7-2b.

3-4. Curvature, Curve Resistance, and Effective Grade.

a. *Minimizing Curvature.* In general, sharper curves require more maintenance than gradual curves; they experience more rail side wear and gage widening. They also create more propulsion resistance. Thus, long term benefits are gained by minimizing curvature in a route.

b. *Curve Design Categories.* Table 3-3 shows curve design categories for main running tracks.

c. *Combining Curves.* When designing a route, changes in direction should be accomplished as uniformly as possible, avoiding a series of curves connected by short tangents. Where the distance between adjacent curves (of the same direction) is less than 300 feet, try to combine the two curves into one long curve of smaller degree (see fig 3-1). Combining closely spaced curves usually provides advantages of less design work, easier construction, and reduced long term track maintenance.

Table 3-1. Grade Design Categories for Main Running Tracks.

0.0 to 0.4%	Light
0.4 to 1.0%	Moderate
1.0 to 2.0%	Steep
1.5%	Suggested Limit for Ruling Grades
2.0 to 3.0%	Very Steep: To be avoided if possible

Table 3-2. Recommended Minimum Grade Lengths.

Maximum Speed	Between Different Ascending or Descending Grades	Between Ascending and Descending Grades
15 MPH or Less	500 Feet	1000 Feet
Above 15 MPH	1000 Feet	1500 Feet

Table 3-3. Curve Design Categories for Main Running Tracks.

Degree of Curve	Design Category
0-3	Gradual.
3-64	Moderate.
4	Preferred limit, especially where speeds will exceed 15 MPH.
.6-8	Sharp.
8	Maximum allowable where speeds may exceed 10 MPH.
10	Maximum allowable where speeds will not exceed 10 MPH.

d. *Curve resistance.* Curvature adds to propulsion resistance at an average rate of 0.8 pounds for each ton of train weight for each degree of curve. As a one percent grade adds resistance of 20 pounds per ton, a one degree curve is then equivalent (in resistance) to 0.04% grade.

e. *Curve Compensation.*

(1) When laying out a route, the additional resistance due to curvature must be accounted for in the design. This procedure is known as curve compensation. Compensating a grade for curvature is almost always required for ruling grades, and is recommended for grades in moderate and higher categories. (Curve compensation is sometimes omitted where curves are very short or of gradual degree).

(2) Where curve compensation is needed, grades on curved track will be reduced by the following:

$$G_r = 0.04 \times D \tag{eq 3-1}$$

G_r = Amount of grade reduction (percent).

D = Degree of curvature (decimal degrees).

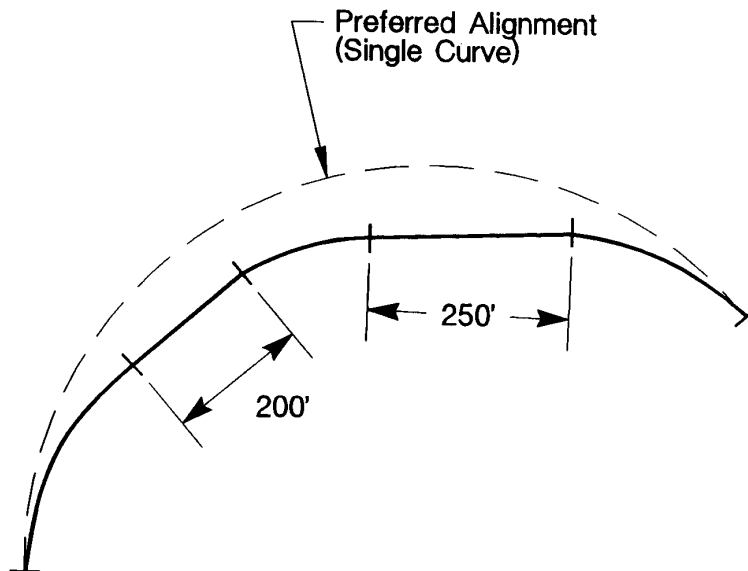

Figure 3-1. Combining Curves.

f. *Actual and Effective Grade.* Table 3-4 illustrates curve compensation for a 1% grade. As shown, if a train travels around a long curve of 4 degrees on a 1% grade (uncompensated), the combined resistance is equal to a 1.16% grade. To maintain an effective grade (as experienced by the train) of 1%, the actual grade constructed through the 4 degree curve must be limited to 0.84%. Since the actual grade is reduced, compensating for curvature requires a longer track length to reach a given elevation.

Table 3-4. Curve Compensation for a 1% Grade.

Degree of Curve	Uncompensated Grade		Compensated Grade	
	Actual	Effective	Actual	Effective
1	1.00	1.04	0.96	1.00
2	1.00	1.08	0.92	1.00
3	1.00	1.12	0.88	1.00
4	1.00	1.16	0.84	1.00
5	1.00	1.20	0.80	1.00
6	1.00	1.24	0.76	1.00

3-5. Locomotive Tonnage Rating.

a. *Definition.* The maximum weight of a train that a locomotive is capable of pulling over a route is known as its tonnage rating. Tonnage ratings are affected by many factors, but locomotive tractive effort and ruling gradient are among the most important.

b. *Application of the Procedures.* The procedures for estimating locomotive tractive effort and tonnage ratings presented below are simplified versions intended for route design purposes. They aren't intended to be used for the actual make-up and dispatching of trains.

c. *Tonnage Requirements, Locomotive Assignments, and their Effect on Route Design.*

(1) The route must be designed to allow trains of sufficient size to travel over the finished line. Maximum train size is determined primarily from usable locomotive tractive effort and the gradients and curvature along the line.

(2) Designers must verify tonnage requirements with the appropriate transportation officers, as well as understand the general operating plan for routine traffic, training exercises, and mobilization.

(3) On military railroads where government owned and operated engines are used, these engines might handle all routine traffic, but during training exercises or mobilization, a commercial engine may be expected to handle over-the-road operations, while the installation's engine takes care of switching and short moves. Another option, when installations have more than one engine, is to use two engines for maximum tonnage trains when such single train movements are required. Thus, in addition to tonnage requirements, plans for locomotive use must also be known.

d. *Determining Locomotive Tractive Effort.*

(1) When tractive effort curves are available for the locomotives to be used on the line, tonnage ratings should be based on these curves. Otherwise, tractive effort may be sufficiently estimated with the expressions in table 3-5.

(2) Regardless of locomotive power, usable tractive effort is always limited by wheel-rail adhesion. For design purposes, usable locomotive

Table 3-5. *Estimating Locomotive Tractive Effort.*

Speed Range	Tractive Effort
Starting to 10 MPH	TE - 30 x HP
Over 10 MPH	TE - 300 x HP/ V

TE = Tractive Effort (in pounds)
 HP = Locomotive Rated Engine Horsepower
 V = Traveling Speed (MPH)

tractive effort should not exceed W/4, where W is the weight of the locomotive in pounds.

e. *Determining Tonnage Rating.*

(1) While tonnage ratings are commonly given in gross trailing tons (total weight of cars and loads), a convenient practice is to express tonnage ratings as the number of loaded cars a locomotive can pull, using an average or representative car and load for estimating purposes. This can be done using equation 3-2, along with table 3-6 for selecting design car gross weight based on the nominal car carrying capacity.

$$N_{cars} = \frac{TE}{[3 + (20 \cdot \%G)] W_g} \quad (eq\ 32)$$

No_{cars} = Number of cars locomotive can pull.
 TE = Usable locomotive tractive effort at desired speed (lbs).
 %G = Maximum ascending gradient long enough to contain the whole train (percent).
 W = Gross weight of representative car (tons), from table 3-7.

The constants 3 and 20 in equation 3-2 indicate that an average car has a rolling resistance of 3 pounds for each ton of its gross weight and that all equipment requires 20 pounds to lift each ton of weight up each percent of grade. Any curvature on the maximum grade is assumed to be grade compensated, as described in section 3-4.

Table 3-6. *Design Gross Car Weights.*

Nominal Car Capacity (tons)	70	80	90	100	120	140
Design Gross Weight (tons)	105	115	125	135	160	190

Note: 140-ton cars (nominal capacity) are representative of those carrying 2 M1 Tanks.

(2) For field check, car capacity is normally stenciled on the side of each car in pounds, labeled CAPY. For example, the marking on a 70-ton car would appear as: CAPY 140000.

3-6. Trial Ruling Grade.

a. A trial percentage for the ruling grade can be determined for guiding the first stages of route selection, using equation 3-3. (The 0.15 constant in the equation indicates that the average rolling resistance for each car is equivalent to pulling the car up an additional 0.15% grade).

G = Effective ruling gradient (percent), where the grade length is equal or greater than train length.
 TE = Usable locomotive tractive effort (pounds).
 W_{ENG} = Weight of Engine(s) (tons).
 N_{Cars} = Number of cars in train.
 W_g = Average gross weight of a car (tons).

b. All curvature within the limits of the ruling grade should be grade compensated, as described in paragraph 3-4.

c. A ruling grade that is steeper, but shorter, than the calculated ruling grade can also be used

as long as the total train resistance of the cars on the grade and the cars off the grade does not exceed usable locomotive tractive force.

CHAPTER 4

ROUTE SELECTION

4-1. Introduction.

a. This chapter describes the process of selecting the route for the track connecting the terminal facilities with the commercial railroad serving the installation.

b. The location process begins by roughly defining potential routes or areas through which a railroad might practically run. Additional and more detailed information is then collected, and the route alternatives are gradually reduced until the final route is chosen. Before this process begins, the initial location and orientation of terminal facilities (as described in chap 9) should be completed.

c. The ideal route is usually the one which:

- (1) Is shortest in length.
- (2) Has the lowest grades.
- (3) Has the least curvature.
- (4) Costs the least to build.
- (5) More conveniently serves the installation

and all terminal areas, as well as connecting carriers.

(6) Causes the least interference with other activities and modes of transportation.

(7) Is environmentally compatible with adjacent land use.

(8) Provides reliability for use in all weather conditions.

d. As the above-listed objectives often conflict, the engineer's job is to determine the appropriate compromises which will produce the best route under the circumstances—the one which best meets all objectives.

e. If initial line locations prove unsatisfactory in some important aspect, it may be desirable to look for a different terminal location or to re-orient a terminal so that the line can serve it from a different direction.

f. Throughout the route selection process, it is essential to have good maps (including contour maps) of the area through which the railroad may run. If not currently available, these should be obtained as the first step.

4-2. Establishing Control Points and Potential Corridors.

a. Control points serve to limit location alternatives. They represent places through which the railroad must pass or would ideally pass.

b. The most obvious control points are end points: the terminals and the connections with the

commercial railroad. Intermediate control points may be established by facilities or geographic features which must be avoided, such as firing ranges, areas which cannot be drained well, or environmentally sensitive areas. Control points can also be places which offer significant construction and operating advantages, such as narrow or shallow river crossings and areas with naturally good drainage.

c. After control points are marked on contour or aerial maps, approximate boundaries of potential route corridors are sketched. More control points, and other information needed to define a specific route, are identified during the next stage: reconnaissance.

4-3. Reconnaissance.

a. The reconnaissance is a quick examination of a wide strip of land between control points: the strip representing rough boundaries of a potential line location. Several routes (or alternatives for portions of a route) may be examined.

b. The purpose of a reconnaissance is to identify routes which might allow the easiest construction effort consistent with the purpose and requirements of the railroad.

c. Contour maps, aerial photographs, and previous survey information are good sources to use during the reconnaissance. A small set of maps and diagrams (with control points and potential routes identified) is convenient for field use. The information gathered during the reconnaissance can then be transferred to larger maps and computer files back in the office.

d. The reconnaissance may be done by any means appropriate for the terrain and distances to be covered: walking, driving, or from the air. Generally, take note of terrain features and anything that might affect route location and construction. Look especially for the following:

- (1) Landmarks for referencing the location.
- (2) Additional control points.
- (3) Areas of potentially easy or difficult construction.
- (4) Roads and utility lines to be crossed.
- (5) Waterways or ravines to be crossed. (Estimate length and height of bridges).
- (6) Drainage paths.
- (7) Soil conditions and geological features.
- (8) Vegetation type and density.

(9) Potential for future additions to the rail- road (as per the Installation Master Plan).

(10) Wetlands and other environmentally sensitive areas.

(11) Snowfall and exposure to drifting snow.

e. Snow conditions along the proposed routes should be observed for at least one winter to identify locations where drifts form. Winter aerial photographs may also be helpful for this purpose. Sites downwind of frozen lakes should be avoided unless there is adequate room between the shore and the roadway to install snow fences.

f. After the reconnaissance has been completed; prepare maps showing all control points and potential alternative routes. Then, make general comparisons between the routes with respect to length, grades, curvature, relative amount of earthwork and drainage work required, bridge work, special construction requirements, and potential operating advantages and disadvantages.

g. If sufficient information is available at this point, recommend the best route; otherwise, prioritize the routes. Also note any special requirements for the initial survey.

4-4. Initial Survey.

a. The objective of the initial survey is to obtain sufficient information to allow preparation of initial earthwork and construction estimates and to establish a location for the track and drainage paths on maps back at the office. When the route choice is clear from the reconnaissance, the initial and final surveys are often combined.

b. The initial survey is done by approximating the routes as a series of tangents, taking elevations and cross section data at selected intervals (perhaps every 100 feet to 250 feet) along the route. Generally, where terrain is fairly uniform, the longer survey intervals can be used. Elevations and cross section data should also be taken at points representing a rapid change in terrain or at other points of special interest which may be useful to aid construction estimating. All useful landmarks should also be tied into the survey. Stakes need to be driven in sufficient number to clearly show the survey centerline-about every 200 to 400 feet.

c. For cross sections (nearby elevations at right angles to the route), simply take elevations at points which will show the shape of the adjacent terrain--local peaks, low points, and other points of special interest. The width of the required cross section will be dictated by the character of the terrain, right-of-way ownership, and distance needed to show local drainage and topographical features. It is not necessary for cross sections to be

of equal distance on each side of the route centerline or of equal width at each station along the route.

d. Where terrain is open (and easily accessible) cross section data is often taken from 300 to 500 feet on each side of the route centerline. In areas where the route location is fairly well defined, cross sections may be much narrower; sometimes only a 50 foot wide strip is needed. The situation should govern the choice of width.

e. When approaching points where a change in direction will occur, it will often prove useful to take an extra wide cross section on the inside of the angle, as a curve must eventually connect the two tangents through this area.

f. During the initial survey be sure to take sufficient information to establish drainage paths on both sides of the track. Also note paths which drain runoff into the right-of-way as well as outlets where water can exit the right-of-way to nearby streams, drop inlets, or other runoff channels.

4-5. Trial Location.

a. Trial location is the process of determining potentially practical routes (trial routes) through a particular area. The objective of trial location is to produce the best combination of tangents, curves, and grades for the routes surveyed. This is done by combining survey information with design and economic guidelines, operating requirements, and engineering judgment. During this process many factors must be weighed and prioritized, and conflicting objectives must be balanced.

b. After the first trial routes are located, construction estimates are made. Then, the location (of the track or drainage path) is usually modified in an attempt to reduce construction cost (while still maintaining satisfactory operating characteristics) or to improve operating characteristics (while keeping construction costs at a reasonable level). Adjustments are made to each route until the most satisfactory set of compromises has been produced.

c. For track through an installation or in a terminal area, this process can usually be simplified and done with fewer iterations. Likewise, the construction estimates might be done only once.

d. Trial location begins by lightly sketching the boundaries of the initial survey on a contour map. The first trial route drawn through this strip is often done by minimizing grades, or in flatter territory, by minimizing the number of curves needed. As with the initial survey, the route begins as a series of connected tangents, with curves chosen and drawn in later.

e. After the route is sketched, a profile is drawn. The elevations of the railroad come from the elevations of end and intermediate points and the different grades chosen between these points. The elevations of existing ground level are obtained by approximating the point where the route would pass through each cross section taken in the initial survey. When an initial survey is not done, the ground elevations are taken from the points where the route crosses map contours.

f. With the trial routes drawn, earthwork and construction estimates are made using standard procedures. At this stage, embankment and cut widths and slope angles may be estimated using the typical roadway cross sections in paragraph 6-4.

If one route does not yet appear clearly superior, an additional iteration of modifications and analysis may be needed to produce the final location.

4-6. Final Location.

a. To finalize the route selection, modifications may be made to the trial routes in an attempt to even cut and fill amounts in adjacent areas or to reduce the total earthwork and grading required.

b. Where grades or curvature exceed the most desirable limits, the routes should be modified, if feasible, to reduce these. The criteria listed in paragraph 4-1 should also be reviewed for each trial route.

CHAPTER 5

REHABILITATION: TRACK, BRIDGES, AND TERMINALS

5-1. Definition and Application.

a. As used here, rehabilitation is work which falls between routine maintenance and new construction. It is often categorized as repair, minor construction, or a combination of the two. Rehabilitation involves restoring facilities to a "like new" condition and/or upgrading existing facilities to current design standards or installation requirements.

b. During the planning process, current and future installation requirements should first be clearly established. If subsequent investigations and analyses show that existing facilities could meet installation requirements through improving their condition and/or minor modifications, then rehabilitation is an appropriate option.

5-2. Installation Requirements and Facility Evaluation.

a. Installation traffic and load carrying requirements should be reviewed, as described in chapter 2. Then, structural and operational requirements should be checked according to the criteria in chapters 6, 7, and 8.

b. The purpose of evaluations should be to determine whether the track and facilities meet installation (mission) requirements, and if not, in what respect they are deficient. These determinations are made through condition, structural, and operational evaluations.

5-3. Condition Evaluation.

a. *Level of Detail Required.* Condition evaluations may occur in three stages or levels, depending on the size and scope of the project:

(1) At the first stage, a quick condition assessment may be appropriate, based on recent inspection reports and inventory information and a brief field survey. This assessment may be used to establish a general need for rehabilitation.

(2) The second stage may be an evaluation for developing a rehabilitation plan. This information will be sufficiently detailed to determine what work needs to be done at which locations, and to develop cost estimates for planning and budgeting purposes.

(3) At the third level, exact work requirements, quantities, and locations are determined for final contract plans and specifications.

b. *Track.*

(1) Track condition evaluation should be based on the criteria given in Army TM 5-628/AFJMAN 32-1048 as well as other major rehabilitation requirements. The evaluation should also allow for major deficiencies which are likely to occur within the next three to five years if rehabilitation is not performed.

(2) Current track deficiencies should be recorded on a field inspection log designed for routine maintenance requirements. All turnouts in the track intended for rehabilitation should receive a thorough inspection, including operating the points. The development of a sequence for the track inspection is important since it actually outlines the plan for inspection. A suggested inspection sequence would consider the main track first recording the condition and spacing of the ties; the rail weight, section and material type; track alignment; surface appearance as related to dirt and debris; and condition of guard rails. The turnouts would be next including the following items:

- (a) Switch operation.
- (b) Switch stand: point lock, lever latches, point gap, point condition, gage measurement just ahead of points.
- (c) Connecting Rod (including bolt).
- (d) Jam Nut.
- (e) Switch Rods (including bolts).
- (f) Switch Clips.
- (g) Side Plates.
- (h) Rail Braces.
- (i) Heel: filler, bolts, joint and shoulder bars.
- (j) Frog: point, top surface, bolts, gage at point, flangeway width and depth.
- (k) Curved Closure Rails: gage at joints.
- (l) Guard Rails: gage at guard check and face, flangeway width.

(3) If records of an internal rail inspection are more than three years old, a new inspection should be made before the rehabilitation plan is completed.

c. *Bridges.*

(1) Railroad rehabilitation plans will include a condition assessment of the bridges on any line to be rehabilitated. This assessment may come from the last annual inspection, if that inspection is less than 6 months old. Otherwise, a new condition assessment will be done.

(2) If a triennial inspection is due within 6 months for any bridge on a line to be rehabilitated, the triennial inspection and load rating (per para 5-4) will be done as part of the rehabilitation plan.

(3) If the last annual inspection indicates any significant change in condition of a main bridge member since the previous load rating was done, at least the included span (or spans) of the bridge will be thoroughly inspected and load rated (per para 5-4) as part of the rehabilitation plan.

d. Terminal and Support Facilities. The condition of all terminal and support facilities should also be evaluated. This evaluation may be done and reported separately from the track evaluation.

5-4. Structural Evaluation.

a. To determine current load carrying capacity, a structural evaluation will be performed for all track, bridges, loading ramps, and other structures needed for railroad and terminal operations.

b. Track structural evaluation should be done using the computer program described in appendix C.

c. Bridges.

(1) The load-carrying capability of a railroad line is often determined by the design capacity and present condition of the bridges along the route.

(2) All bridges which have not been thoroughly inspected and load rated within the previous three years will be examined and rated by a practicing railroad bridge engineer. The rating will be done in accordance with the AREA manual for timber bridges, concrete bridges, and steel bridges.

(3) Most military railroad bridges are of conventional timber design, built to an E60 rating. If these bridges are in very good condition, this capacity is sufficient for typical military traffic levels, including handling of 140-ton heavy equipment flatcars.

(4) By the AREA rating guidelines, the inservice rating for bridges in very good condition may actually exceed their design rating.

(5) Additional material on bridge design ratings is found in paragraph 6-17.

5-5. Operational Evaluation.

a. To determine general suitability for mission requirements, an operational evaluation will be performed on track and facilities. This evaluation should begin with a check of track and facility capability as well as basic geometric requirements, including:

(1) Number of loading and service tracks, along with usable car capacity of each.

(2) Car capacity of storage, yard, and auxiliary tracks.

(3) Clearances.

(4) Loading ramp height, width, and ramp angle.

(5) Size of parking and staging areas.

(6) Size of storage buildings in terminal areas.

(7) Track geometry.

(8) Maximum track curvature.

(9) Minimum turnout size.

(10) Protection and visibility at road crossings.

b. For terminals, the adequacy of lighting, service roads, and security features should be evaluated.

c. For all track and facilities, adequacy of drainage should be checked.

d. Previous derailment sites and chronic problem areas should be included in the evaluation.

5-6. The Rehabilitation Plan.

a. *Purpose and Content.* The rehabilitation plan is used, in part, to justify the need for the recommended work. Thus, it should demonstrate a thoughtful analysis of the existing facilities combined with a clear understanding of mission requirements. The plan should include the following:

(1) Statement of installation (mission) requirements.

(2) Description of track and facilities and their current condition.

(3) Statement of deficiencies, based on condition, structural, and operational evaluations.

(4) A work plan of remedial actions to correct deficiencies, including an explanation of why the proposed actions were chosen over other alternatives.

(5) Cost estimates for each item in the work plan. Each of these items is discussed below. Appendix D contains an example track rehabilitation report; a similar format would also be used for bridges and terminal and support facilities. Appendix D presents realistic rehabilitation requirements and illustrates how track rehabilitation is commonly done. This plan, and particularly the sequential description of work, should be studied and used as a guide in preparing track rehabilitation plans.

b. *Mission Requirements.* These are the current and expected future needs for regular traffic, training exercises, and mobilization, including amount and type of cargo, number and type of railroad cars to be handled, and terminal and support facilities requirements.

c. *Description of Rack, Bridges, and Facilities.*

(1) This includes a written description of facilities and their condition, along with track maps and photographs.

(2) If not previously done, each track, bridge, and turnout should be assigned a unique number (or other designation). Each track should be marked with standard surveyor's stationing to help determine work and material quantities (from track lengths) and work locations, and to provide permanent reference location marks for future track inspections. In general, track stationing should start with 0+00 at the point of the switch where the track branches from the main track, or for a main track, at the point where government ownership begins (at the connection with the serving commercial carrier).

d. Deficiencies List and Analysis. This section should include a description of the major deficiencies found and an explanation of how these conditions interfere with, or prevent, the facilities from effectively supporting the required mission. As part of this explanation, a comparison of the existing facilities to recommended design criteria can be useful. Photographs should also be included to help document deficiencies.

e. Work Plan.

(1) The work plan includes a listing of recommended remedial actions for correcting deficiencies, along with a list of the intended work limits. This section of the rehabilitation plan should also clarify why these actions were chosen, and where appropriate, what advantages and benefits they have over other alternatives. As an example, when a structural analysis indicates the need for a heavier rail section, eliminating the lighter rail often allows the installation to standardize with only one or two rail sections, thus requiring fewer sections to be kept for maintenance requirements and perhaps eliminating a section for which joint bars (or additional pieces of rail) are hard to find.

(2) If the rehabilitation plan will also serve for final plans and contract specifications, then the work plan must include all details of work to be done.

(3) Where appropriate, plans should also allow for the elimination of unneeded track, the possibility of re-using track materials elsewhere within the installation (where traffic and structural requirements are lower), and the cost-effective sale, transfer (to another installation), or disposal of scrap and salvageable materials.

(4) For rehabilitation, track should be regaged if the existing gage is less than 56-1/4 inches or greater than 57 inches.

f. Cost Estimates. For plans for major rehabilitation, cost estimates are usually based on costing

the major work items, with extra allowances for minor work at other locations and additional minor work within the major work locations or work categories. When the rehabilitation plan is done in one stage, the cost estimates must also serve for the contract plans and specifications. In this case, the cost estimate breakdown must be more detailed.

5-7. Final Plans and Specifications.

a. Detailed Work Plan. For final (contract) plans and specifications, all work must be spelled out in detail. If not previously done, thorough inspections should be conducted for all included facilities to assure correctness of work requirements, work locations, and work and material quantities.

b. Marking Parts to Be Replaced. At this time, all ties, rail, joint bars, bridge members, and other components intended for replacement should be individually marked, as well as the limits for all work locations. When marking defective parts, especially ties, bridge members, switch points, and frogs, those items which are in marginal condition (less than three to five years additional life) should also be included (and marked) for replacement.

c. Top-of-Rail Profiles.

(1) When ballast is added to the track, and the track is to be raised by three or more inches, top-of-rail profiles (elevations along the top of the rail at 50 to 200 foot intervals) should be taken so the final surface can be checked. These profiles will also help in estimating ballast quantities; this is especially useful if existing track surface is poor, as many low areas will likely need to be raised more than average to restore a smooth final surface.

(2) Initial top-of-rail profiles may be useful for track along loading docks to ensure proper car floor height at the dock.

(3) Top-of-rail profiles should be taken wherever overhead clearances are tight.

d. Drainage Profiles and Cross Sections. Before final plans and estimates are made, ditch profiles and cross sections should be taken to determine final ditch gradients and check earthwork quantities. These profiles are also needed to specify the exact work to be done and to guide the contractor's work in the field.

e. Handling Scrap and Salvage Materials.

(1) Rehabilitation contracts and specifications should require that scrap rail and other track materials be neatly stacked and/or bundled in a designated storage area for later disposal. Likewise, salvageable rail and OTM should be separated by type and weight, stacked or containerized, and stored in a designated area for reuse by

the installation or shipment to another installation.

(2) If scrap materials are to be retained by the contractor, a cost credit for the amount of scrap should be received by the government. This cost credit should equal the fair scrap value less a small amount for handling and transporting the material.

5-8. Construction and On-Site Inspection.

a. Quality on-site inspection, during all remedial work, is an essential element for a successful track rehabilitation. While such inspection is certainly no substitute for professionally done track work, it is an effective means of assuring that all work is, in fact, performed according to the contract specifications.

b. On-site inspection during rehabilitation work can discover deficiencies or errors which would be difficult to detect during a completion inspection, or expensive to correct if discovered only after work was completed. Such items include:

(1) Was all excess vegetation removed before ballast was unloaded?

(2) Where track in crossings was to be completely rebuilt, was the old ballast completely stripped?; was the subgrade properly graded?; was drainage fabric installed?; were all new ties installed?

(3) Did the track actually receive a full 3" raise (or were the rough spots just smoothed out)?

(4) Was every tie tamped; did each tie get 2 insertions by the tamper; did joint ties (on the joint side only) get an additional (third) insertion? Likewise, correcting the following items after the work has been done would be difficult, at best.

(5) Tie and ballast material not as specified in the contract.

(6) Old, fouled ballast in shoulders not fully plowed out before new ballast was unloaded.

(7) Culvert improperly positioned, or site not graded properly before culvert was installed.

(8) Defective concrete or insufficient reinforcing in loading ramp.

c. It is recommended that the work be inspected by the same people who did the design and specifications.

CHAPTER 6

STRUCTURAL DESIGN

6-1. Track Structure.

a. Design objective. Among its various functions, the track system serves to distribute the large, concentrated wheel loads longitudinally, laterally, and vertically away from the wheel contact area on the rail surface. A well designed, constructed, and maintained track will distribute the loads in a relatively uniform fashion, with each component supporting its share of the load. The role of the designer is to select a track structure (or changes to an existing track) so that the intended wheel loads will be properly supported, without overstressing any of the four main track system components: rail, ties, ballast, and subgrade.

b. Load distribution. As shown in figure 6-1, when a wheel is centered over a tie, the tie directly beneath the load will generally carry less than half of that wheel load, with the remainder supported by two ties on either side. Beneath the wheel, the pressures are distributed (reduced) approximately as shown in figure 6-2. With a wheel-rail contact area of about 1/2 square inch, stresses are reduced from 60,000 psi at the top of the rail to about 10 psi at the depth of the subgrade surface. While the actual load and pressure distributions will vary with wheel load, track design, and track condition, the two figures illustrate a realistic case for good track.

c. Behavior under load. It is important to note that while track construction is relatively simple, its behavior under load is not. An improvement (or increase in strength) in one track component may cause an increased load on another. This is a common occurrence and is illustrated in the example in appendix C, using the TRACK program.

6-2. Track Design Methods.

a. Computer Programs Available. Computer programs for basic track structure design are available through the PCASE Bulletin Board and the Army Transportation Systems Center (CEMRDED-TT). Their use is recommended. Appendix C provides guidance on the use of one structural analysis program.

b. Manual Design Procedure. If computer programs are not accessible or a computer is unavailable, the design procedure in paragraph 6-3 may be used as an alternative. A disadvantage of this method, however, is that very little data exists to correlate the value of track modulus with the

properties of individual rail support components: ties, ballast, and subgrade.

6-3. Area Design Procedure (Modified).*a. Applying the AREA Method to Military Track.*

(1) The AREA method leaves several choices and judgments open to designers, to be set according to situation and policy. And like most AREA criteria, the method is also oriented toward those commercial lines which carry medium to heavy traffic volumes (more than 10 million gross tons per year) and operate at medium or higher speeds (more than 40 mph).

(2) The guidance below is based on recognizing that most military track operates at relatively low traffic volumes (less than 5 million gross tons per year) and at relatively low speeds (less than 25 mph), and uses jointed, rather than continuously welded, rail.

(3) For unusual cases where yearly traffic frequencies are expected to exceed 5 million gross tons, designers may follow the method directly from chapter 22 of the AREA manual.

b. Basis for Design.

(1) The AREA track design method is based on extensive field and laboratory testing conducted between 1914 and 1940. The committee supervising the tests and evaluations was led by Professor Arthur Talbot of the University of Illinois, whose name is often used when referring to the tests and findings.

(2) One of the Talbot Committee's findings was that, when subject to a large number of load repetitions ("millions of groups of car wheels"), the greater the vertical rail deflection under those loads, the faster the track condition deteriorated. From the data and observations collected, the AREA then developed a track design method based on limiting or controlling vertical rail deflection.

(3) Figure 6-3 illustrates the general relationship between track deflection and track performance over long time periods. The design criteria in this section are based on limiting the deflection of main running tracks to 0.3 inches and of auxiliary, storage, spur, and light use tracks to 0.4 inches.

(4) The AREA track design method uses the beam-on-elastic-foundation model. In this model, the track has two components: the beam, which is the rail, and the elastic foundation, which represents everything below the rail combined. The

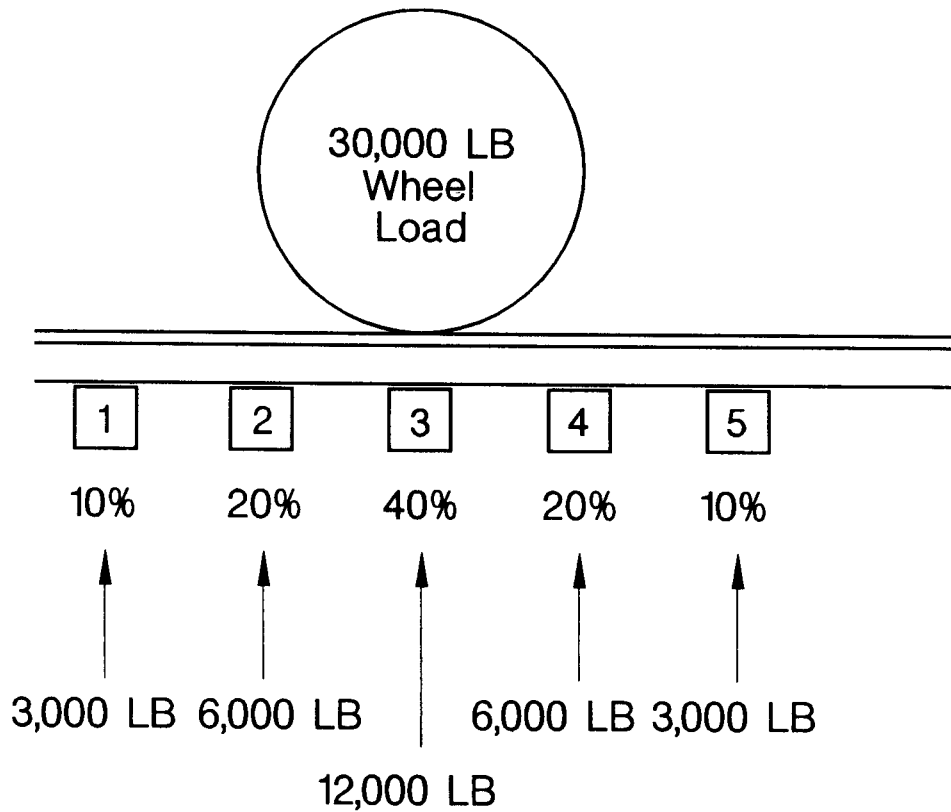

Figure 6-1. Example load distribution along the track.

basic expression in the model relates three main variables: the load on the rail, the stiffness of the track system, and the amount of vertical rail deflection, as follows:

$$Y = \frac{P}{(64EIu^3)^{0.25}} \quad (\text{eq 6-1})$$

Y = vertical rail deflection at a point (inches).

P = applied wheel load (including contributions from adjacent wheels) (lbs).

EI = stiffness of the rail, where:

E = modulus of elasticity for steel (30 x 106 psi).

MI = vertical moment of inertia of the rail section (inches⁴).

u = stiffness of rail support, or track modulus (psi).

In this equation, EI represents the stiffness of the "beam" and u the stiffness of the "elastic foundation."

c. Design Load and Wheel Spacing.

(1) Select the design wheel load from table 2-2, based on the most common, heaviest car expected to travel over the track.

(2) Figure 6-4 shows the two most common wheel configurations. Most cars have 2-axle trucks and the design wheel configuration is that in drawing (a), with an average 75-inch wheel spacing. The 140-ton series flat cars (for carrying M-1

tanks and other heavy vehicles) and some 100-ton flat cars have 3-axle trucks; their design wheel configuration is that in drawing (b), with 66-inch wheel spacing.

(3) The track is evaluated assuming that a wheel is centered over a tie, with an adjacent wheel on either side contributing to the loads, deflections, and stresses-as occurs when two cars are coupled together. Referring to figure 6-4(a), the maximum tie, ballast, and subgrade loads will occur under wheels 2 and 3, while the maximum rail bending stress will occur at wheels 1 and 4. For the wheel configuration in figure 6-4(b), the maximum tie, ballast, and subgrade loads will occur under wheels 2 and 5, while the maximum rail bending stress will occur at wheels 1 and 6.

(4) The effect of wheels farther than 100 inches from the design wheel is negligible.

d. Select Trial Track Modulus (u). The track modulus values listed in table 6-1 are suggested starting points for design. In the table, track type "main" refers to main running tracks, while "auxiliary" includes sidings, wyes, loading, spur, storage, interchange, and light use tracks.

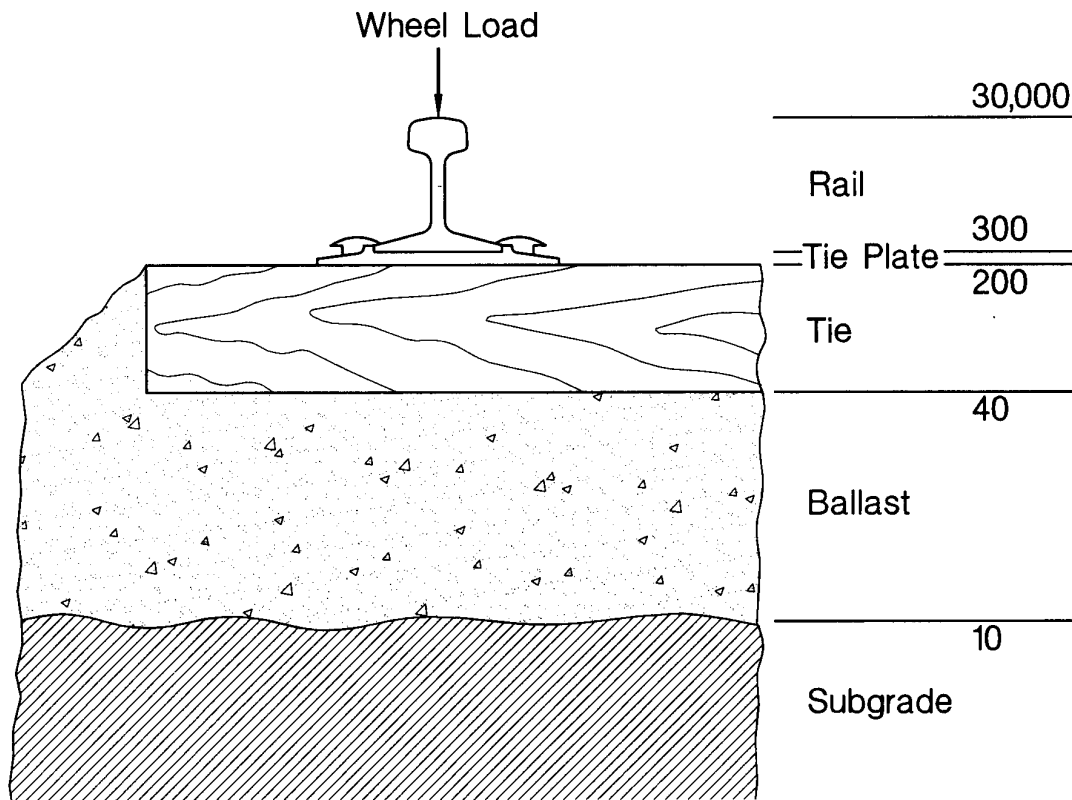
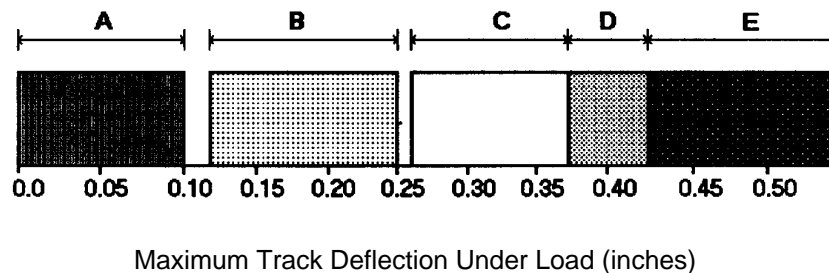

Figure 6-2. Example vertical pressure reduction through the track.



Range Long Term Track Performance

- A ----- Excessively stiff track.
- B ----- Track of heavier construction which will hold up well under large traffic volumes (> 15 MGT).
- C ----- Track suitable for lower traffic volumes (< 15 MGT).
- D ----- Sidings and other auxiliary tracks on low traffic lines.
- E ----- Track which will deteriorate quickly: only suitable for occasional movements with cars less than 100 tons capacity.

Note: Deflections do not include any play or looseness between track components.

Figure 6-3. Relationship between maximum track deflection and long term track performance.

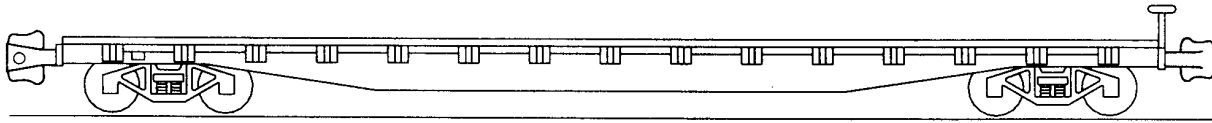

A. Cars with 2-axle trucks



B. Cars with 3-axle trucks

Figure 6-4. Design wheel configurations.

Table 6-1. Suggested Design Track Modulus Values.

Track Type	Design Wheel Load Range (1, 000's of pounds)					
	20-25	25-30	30-35	35-40	40-45	45-50
Main	1500	1800	2000	2300	2600	2900
Auxiliary	1200	1300	1500	1700	2000	2200

e. Select Rail Size.

(1) Use the following equation to determine a minimum rail weight:

$$W_o = 315 - \frac{21200}{\frac{(P)}{1120} (\alpha) + 67} \quad \text{(eq 6-2)}$$

W_o = Weight of rail (lbs/yd)

P = Design wheel load (lbs)

α = Impact factor:

α = 1, where design operating speed is 25 mph or less.

α = 1.4, where design operating speed is more than 25 mph.

(2) Select a rail section from table 6-2 of equal or greater weight than calculated above.

Table 6-2. Rail Sections.

Rail Section	Moment of Inertia: I (inches ⁴)	Section Modulus to Base: Z_b (inches ³)
100 ARA-B	41.3	15.7
112 RE	65.5	21.8
115 RE	65.6	22.0
130 RE	77.4	25.5
132 RE	88.2	27.6
133 RE	86.0	27.0
136 RE	95.4	28.4

f. Determine Moment and Loading Coefficients.

(1) The moment and loading coefficients account for the affects of wheels adjacent to the

design wheel. Adjacent wheels reduce rail moment and increase tie, ballast, and subgrade load.

(2) Calculate X_1 using equation 6-3. (X_1

should normally range between 28 and 40):

x_1 = Distance from design wheel load to point of zero bending moment (inches).

$$X_1 = 82 \sqrt[4]{\frac{I}{u}} \quad (\text{eq 6-3})$$

I = Vertical moment of inertia of rail section (inches⁴).
 u = stiffness of rail support, or track modulus (psi).

(3) Determine coefficients C_m and C_d as follows:

(a) For most design situations, and for cars with either 2-axle or 3-axle trucks, the rail moment coefficient (C_m) can be taken as 0.8.

(b) The load coefficient C_d can be taken from the following table:

X_1 =	28	30	32	34	36	38	40
Design Wheel Spacing:	66:	1.24	1.30	1.36	1.44	1.54	1.62
	75:	1.08	1.15	1.22	1.30	1.36	1.42

g. Check Rail Bending Stress. Use equation 6-4 to check that rail bending stress is less than 32,000:

$$f_o = \frac{(0.318 P_d C_m X_1)}{Z_b} \quad (\text{eq 6-4})$$

f_o = Maximum flexural stress (psi).

P_d = Dynamic (design) wheel load (lbs).

C_m = Moment coefficient.

x_1 = Distance from wheel load to point of zero bending moment (inches).

Z_b = Section modulus of rail base, from table 6-2 (inches).

h. Ties and Tie Spacing.

(1) Choose a trial tie spacing and calculate the maximum rail seat load using equation 6-5:

$$q_o = \frac{0.39 P_d C_d S_1}{X_1} \quad (\text{eq 6-5})$$

q_o = Maximum rail seat load (lbs).

P_d = Dynamic (design) wheel load (lbs).

C_d = Load coefficient for adjacent wheels.

S = Tie spacing (inches).

X_1 = Distance from wheel load to point of zero bending moment (inches).

(2) Select tie size, either 6" x 8" x 8.5 feet or 7" x 9" x 8.5 feet.

(3) Check tie bending stress using equation 6-6a

$$\text{For 6 x 8 Ties: } ft = \frac{q_o}{29} \quad (\text{eq 6-6a})$$

or 6-6b, and $ft = 1100$ psi as a suggested limit:

$$\text{For 7 x 9 Ties: } ft = \frac{q_o}{52} \quad (\text{eq 6-6b})$$

f_t = Flexural stress on underside of tie below rail seat (psi).

q_o = Maximum rail seat load (lbs).

(4) If $ft > 1100$, choose a larger tie size or decrease tie spacing.

i. Ballast and Subgrade.

(1) Determine ballast surface stress from equation 6-7, with $P_m = 6-5$ psi as a suggested limit:

$$P_m = \frac{q_o}{A_b} \quad (\text{eq 6-7})$$

P_m = Ballast surface stress (psi).

q_o = Maximum rail seat load (lbs).

A_b = Effective bearing area of 1/2 tie on ballast (in²).

For 6 x 8 ties, $A_b = 270$.

For 7 x 9 ties, $A_b = 312$.

(2) If P_m exceeds 65 psi, choose a larger tie and/or decrease tie spacing.

(3) Select design subgrade bearing capacity (P_c) according to results of soil tests, the guidance in paragraph 6-5d, or other data. (In the absence of other guidance, the design bearing capacity for cohesive soils may be the same as the unconfined compressive strength.)

(4) Determine ballast depth from equation 6-8:

h = Ballast depth in inches.

P_m = Ballast surface stress (psi).

P_c = Design subgrade bearing capacity.

6-4. Roadway.

The roadway is the strip of land containing the track, ditches, and other facilities needed for the operation of the railroad. When planning a route, roadway width can be estimated from the standard cross sections shown in figures 6-5 through 6-11.

6-5. Subgrade.

a. Subgrade Stability and Tack Performance. The subgrade is the prepared earth on which the railroad ballast section and track structure are built. If the subgrade does not have sufficient stability, it will be impossible to maintain proper track alignment, profile (surface), and cross level.

b. Soil Investigation. Prior to initial design of the track structure, a geotechnical investigation should be performed along the proposed alignment to determine soil type, strength, bearing capacity, location of groundwater tables, natural water content, and compaction characteristics. Additional geotechnical borings, laboratory testing, and engineering analysis will be required in areas where bridges or other special structures are to be constructed. Chapter 1, Part 1 of the AREA Manual

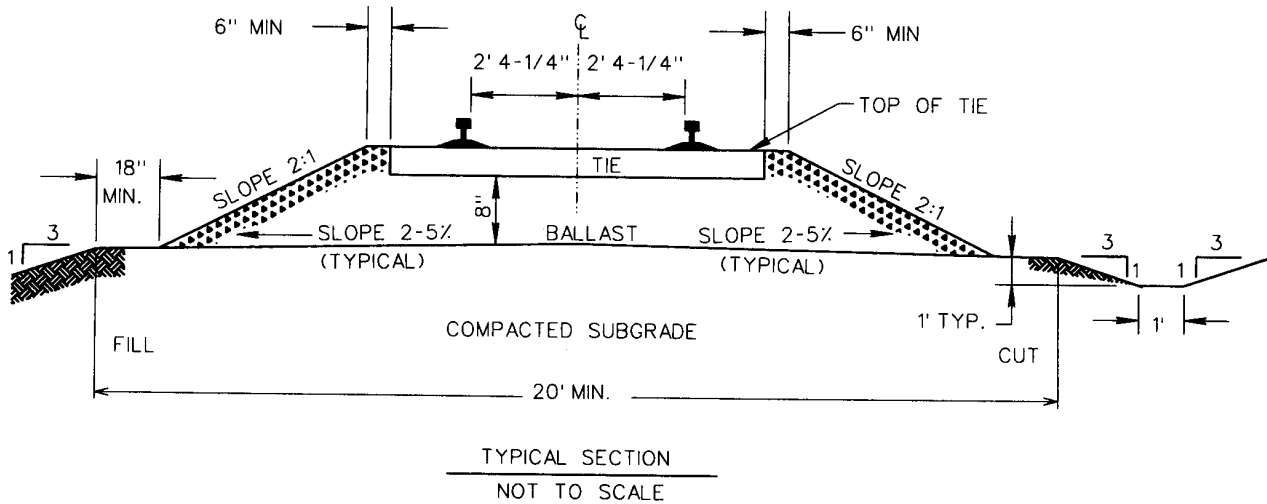

NOTES:

1. DEPTH OF BALLAST TO BE USED WILL DEPEND ON SUBGRADE STRENGTH, TRAFFIC DENSITY, AND WHEEL LOADS. USE RECOMMENDED STRUCTURAL ANALYSIS TO DETERMINE APPROPRIATE DEPTH FOR EACH SITE.
2. MINIMUM BALLAST DEPTH IS 8 INCHES BELOW BOTTOM OF TIE.
3. CUT OR FILL ACCORDING TO LOCAL CONITIONS.

Figure 6-5. Typical cross section-tangent track.

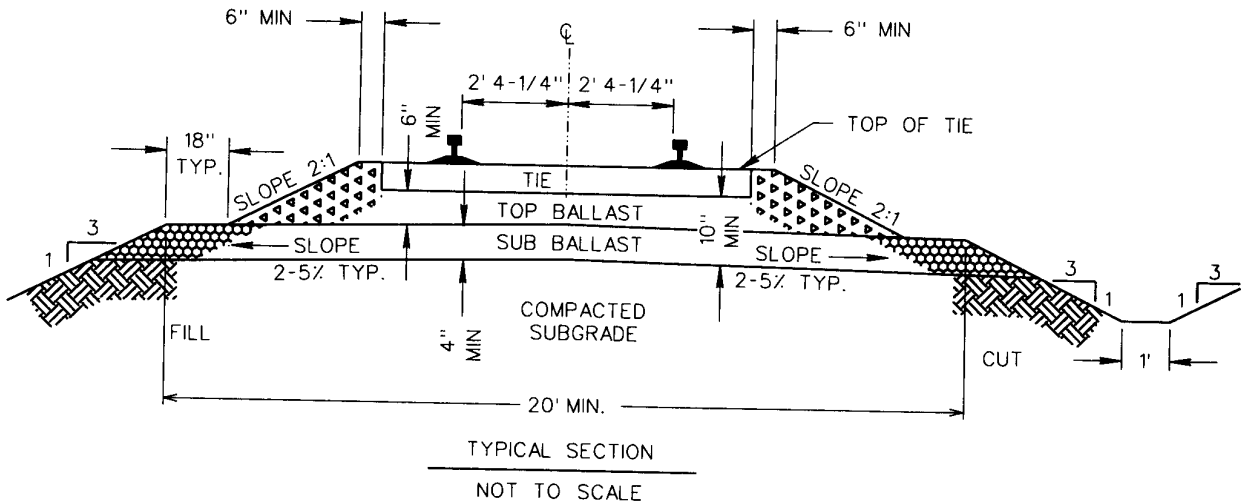

NOTES:

1. DEPTH OF BALLAST SECTION WILL DEPEND ON SUBGRADE STRENGTH, TRAFFIC DENSITY, AND WHEEL LOADS. USE RECOMMENDED STRUCTURAL ANALYSIS TO DETERMINE APPROPRIATE DEPTH FOR EACH SITE.
2. MINIMUM DEPTH OF BALLAST IS 10 INCHES BELOW BOTTOM OF TIE
3. THICKNESS OF BALLAST AND SUBBALLAST MAY BE VARIED TO OBTAIN BEST STRUCTURAL AND ECONOMIC DESIGN WHILE MEETING MINIMUM THICKNESS REQUIREMENTS.
4. CUT OR FILL ACCORDING TO LOCAL CONDITIONS.

Figure 6-6. Typical cross section with sub-ballast layer-tangent track.

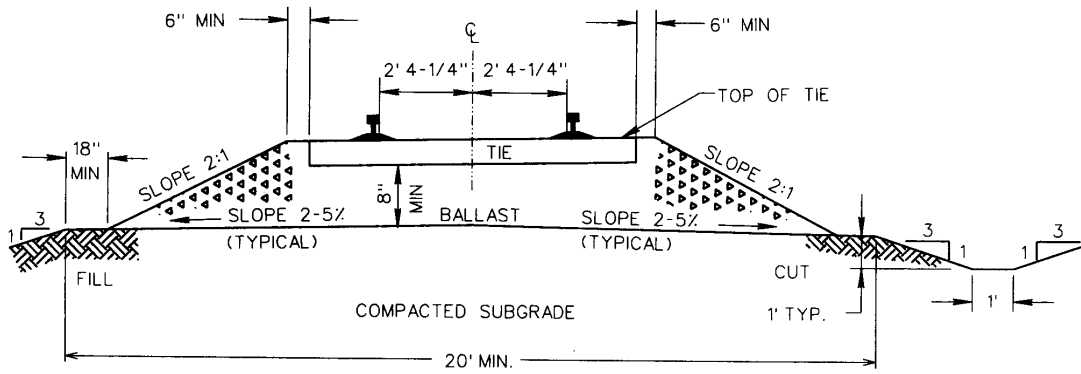

TYPICAL SECTION
NOT TO SCALE

NOTES:

1. DEPTH OF BALLAST SECTION WILL DEPEND ON SUBGRADE STRENGTH, TRAFFIC DENSITY, AND WHEEL LOADS. USE RECOMMENDED STRUCTURAL ANALYSIS TO DETERMINE APPROPRIATE DEPTH FOR EACH SITE.
2. MINIMUM DEPTH OF BALLAST IS 8 INCHES BELOW THE BOTTOM OF THE TIE AT THE LOW (INSIDE) RAIL OF THE CURVE.
3. ON CURVES OF 6 DEGREES OR GREATER A BALLAST SHOULDER WIDTH OF 8 INCHES SHOULD BE USED.
4. CUT AND FILL ACCORDING TO LOCAL CONDITIONS.

Figure 6-7. Typical cross section-curved track.

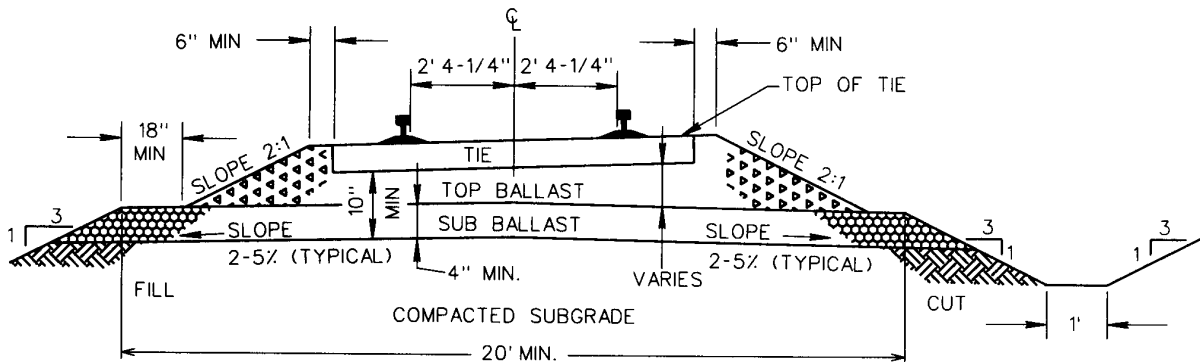

TYPICAL SECTION
NOT TO SCALE

NOTES:

1. DEPTH OF BALLST SECTION WILL DEPEND ON SUBGRADE STRENGTH, TRAFFIC DENSITY, AND WHEEL LOADS. USE RECOMMENDED STRUCTURAL ANALYSIS TO DETERMINE APPROPRIATE DEPTH FOR EACH SITE.
2. MINIMUM DEPTH OF BALLAST/SUBBALLAST IS 10 INCHES BELOW BOTTOM OF TIE.
3. THICKNESS OF BALLAST AND SUBBALLAST MAY BE VARIED TO OBTAIN BEST STRUCTURAL AND ECONOMIC DESIGN WHILE MEETING MINIMUM THICKNESS REQUIREMENTS.
4. ON CURVES OF 6 DEGREES OR GREATER A BALLAST SHOULDER WIDTH OF 8 INCHES SHOULD BE USED.
5. CUT OR FILL ACCORDING TO LOCAL CONDITIONS.

Figure 6-8. Typical cross section with sub-ballast layer-curved track.

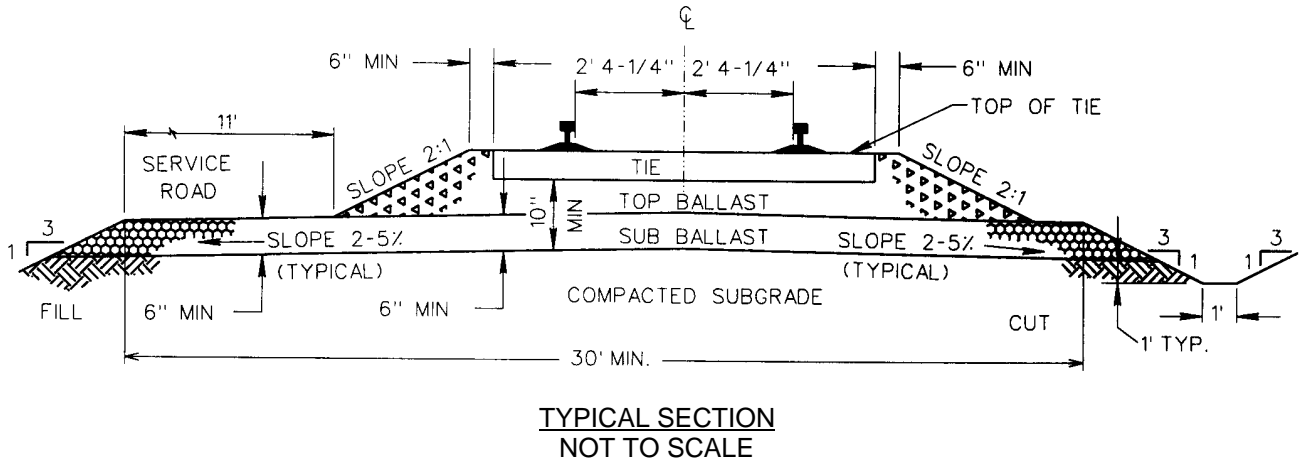

NOTES:

1. USE RECOMMENDED STRUCTURAL ANALYSIS TO DETERMINE APPROPRIATE BALLAST DEPTH FOR EACH SITE.
2. TO BE USED ONLY WHERE A SERVICE ROAD IS REQUIRED. SERVICE ROAD TURN AROUND REQUIRED EVERY 2,000 FEET.
3. FOR USE WITH SERVICE ROAD, SUBBALLAST MATERIAL WILL BE AGGREGATE-SOIL MIXTURE REQUIREMENTS OF ASTM D-1241, TYPE 1, GRADUATION A, B, C, OR D.
4. SUBBALLAST WILL BE A MINIMUM OF 6 INCHES DEEP AND COMPACTED AT LEAST 90% OF THE CE 55 MAXIMUM DRY DENSITY.
5. CUT AND FILL ACCORDING TO LOCAL CONDITIONS.

Figure 6-9. Typical cross section-track with adjacent service road.

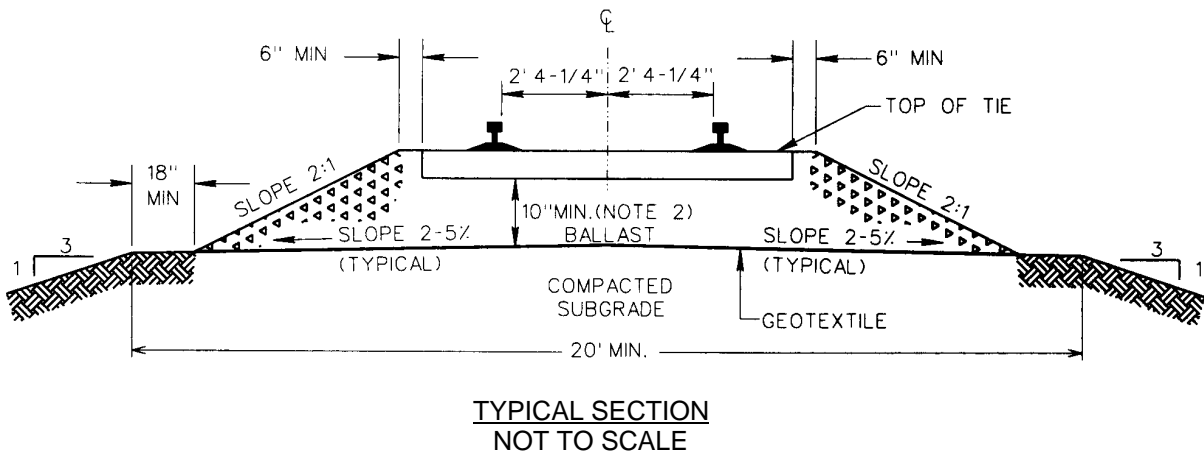

NOTES:

1. DEPTH OF BALLAST SECTION WILL DEPEND ON SUBGRADE STRENGTH, TRAFFIC DENSITY, AND WHEEL LOADS. USE RECOMMENDED STRUCTURAL ANALYSIS TO DETERMINE APPROPRIATE DEPTH FOR EACH SITE.
2. MINIMUM DEPTH OF BALLAST/SUBBALLAST IS 10 INCHES BELOW THE BOTTOM OF TIE AT THE LOW (INSIDE) RAIL OF THE CURVE WITH AREA GRADATION 5.12" MINIMUM DEPTH WITH AREA GRADATIONS 3, 4, AND 4A.
3. GEOTEXTILE TO MEET THE REQUIREMENTS OF CEGS 02274.
4. GEOTEXTILE INSTALLATION ON CURVES WILL BE SIMILAR.

Figure 6-10. Typical cross section-track with geotextile.

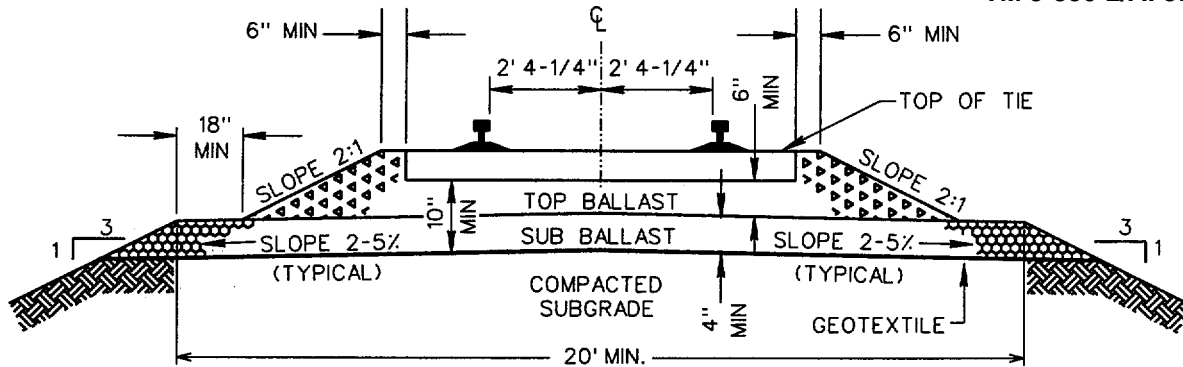

TYPICAL SECTION
NOT TO SCALE

NOTES:

1. DEPTH OF BALLAST SECTION WILL DEPEND ON SUBGRADE STRENGTH, TRAFFIC DENSITY, AND WHEEL LOADS. USE RECOMMENDED STRUCTURAL ANALYSIS TO DETERMINE APPROPRIATE DEPTH FOR EACH SITE.
2. MINIMUM DEPTH OF BALLAST/SUBBALLAST IS 10 INCHES BELOW BOTTOM OF TIE AT THE LOW (INSIDE) RAIL OF THE CURVE WITH AREA GRADATION 5. 12" MINIMUM DEPTH WITH AREA GRADATIONS 3, 4, AND 4A.
3. THICKNESS OF BALLAST AND SUBBALLAST MAY BE VARIED TO OBTAIN BEST STRUCTURAL AND ECONOMIC DESIGN WHILE MEETING MINIMUM THICKNESS REQUIREMENTS.
4. GEOTEXTILES TO MEET THE REQUIREMENTS OF CEGS-02274.
5. GEOTEXTILE INSTALLATION ON CURVES WILL BE SIMILAR.

Figure 6-11. Typical cross section with sub-ballast layer-track with geotextile.

provides recommendations for geotechnical investigations.

c. *Design of Cuts and Fills and Subgrade Preparation.* Chapter 1, Part 2 of the AREA manual provides recommendations for design of cuts and fills and subgrade preparation. The AREA manual indicates soils types and their suitability as railroad subgrades.

d. *Track Structure Design Bearing Capacity-Cohesive Soils.* For cohesive soils, and for track expected to carry the usual military traffic level of less than 5 million gross tons per year, design bearing capacity for the track structure may be set at the soil's unconfined compressive strength at its natural water content. For unusual cases, where annual traffic volumes are projected at higher than 5 million gross tons, 80% of the unconfined compressive strength may be used as the design bearing capacity.

e. *Soil Stabilization.* Information on the use of soil stabilization and the design and construction of soil stabilized subgrades is presented in TM 5-822-4/AFJMAN 321019. Especially in frost areas, soil stabilizers should be used with caution and only after intensive laboratory testing, including a frost susceptibility test and a freeze-thaw durability test.

6-6. Frost Design Modifications.

a. *Frost Heave Conditions.* Frost heaving is the rising of the soil due to the growth of ice lenses or ice segregation during freezing. There are three basic conditions which must be present for ice segregation to occur: a frost susceptible soil, a source of water, and freezing temperatures. A change in any of the three conditions will affect the amount of heave.

b. *Identifying Frost Susceptible Soils.* For design purposes, the potential for ice segregation is often expressed as a function of grain (or particle) size. Most organic, nonuniform soils containing three percent or more by weight of particles smaller than 0.02 mm are considered frost susceptible. Gravels, well graded sands and silty sands (especially those approaching the theoretical maximum density curve) that contain 1.5 percent to 3 percent of particles smaller than 0.02 mm should be considered possibly frost susceptible and subject to laboratory frost-susceptibility tests. Considerable ice segregation can be expected in uniform sandy soils with greater than 10 percent smaller than 0.02 mm. Figure 6-12 illustrates a method for determining the frost susceptibility of soils.

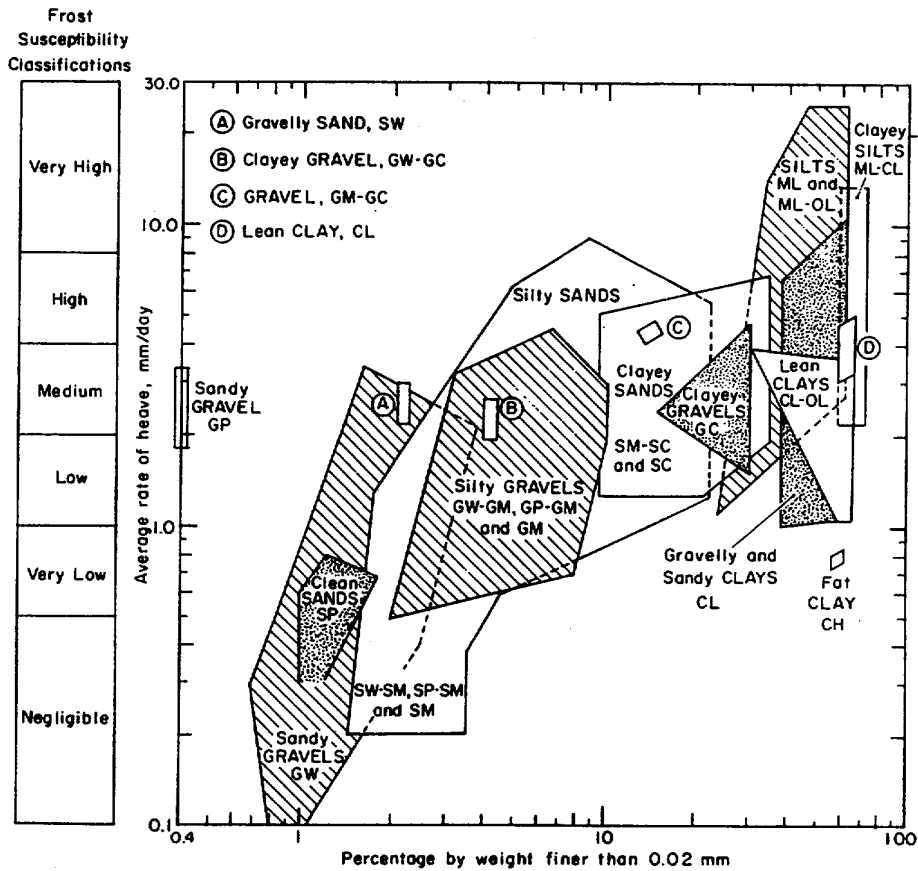

e. Summary Envelopes

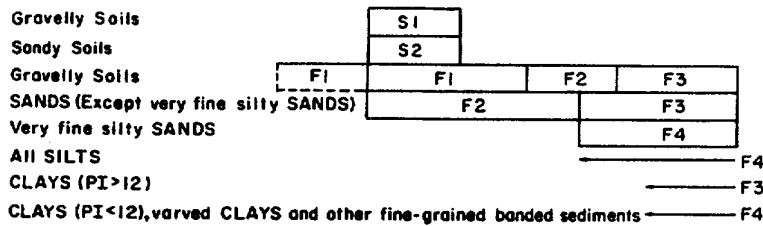

Figure 6-12. General method for determining the frost susceptibility of soils.

c. *Water Source.* Usually, the water source will be an underlying groundwater table, a perched aquifer or infiltration from the overlying layers.

d. *Frost Depth.* Future track maintenance costs are reduced if the design depth of frost below the top of the ballast is at least 60 percent of the expected local frost depth. The expected frost depth should be established using local records, experience or building practices. If these are unavailable, use the procedures in TM 5-852-6/AFR 8-19, chapter 6.

e. *Alternate Frost Depth Procedure.*

(1) This procedure may only be used for fine grained silty soils of relatively uniform composition at different depths.

(2) Determine the Air Freezing Index—the number of degree days (above and below 32°F) between the highest and lowest points on the cumulative degree day curve for a freezing season. Or the design air freezing index use the three coldest years in the last thirty years of record, or use the average index and multiply it by 1.75. (If fewer than thirty years of data are available, the air freezing index for the coldest year in the last ten-year period may be used). If local records are unavailable use the values directly from figure 6-13.

(3) Determine the frost depth using figure 6-14. The gravel thickness in this figure is the total depth of ballast and subballast. Multiply the frost penetration

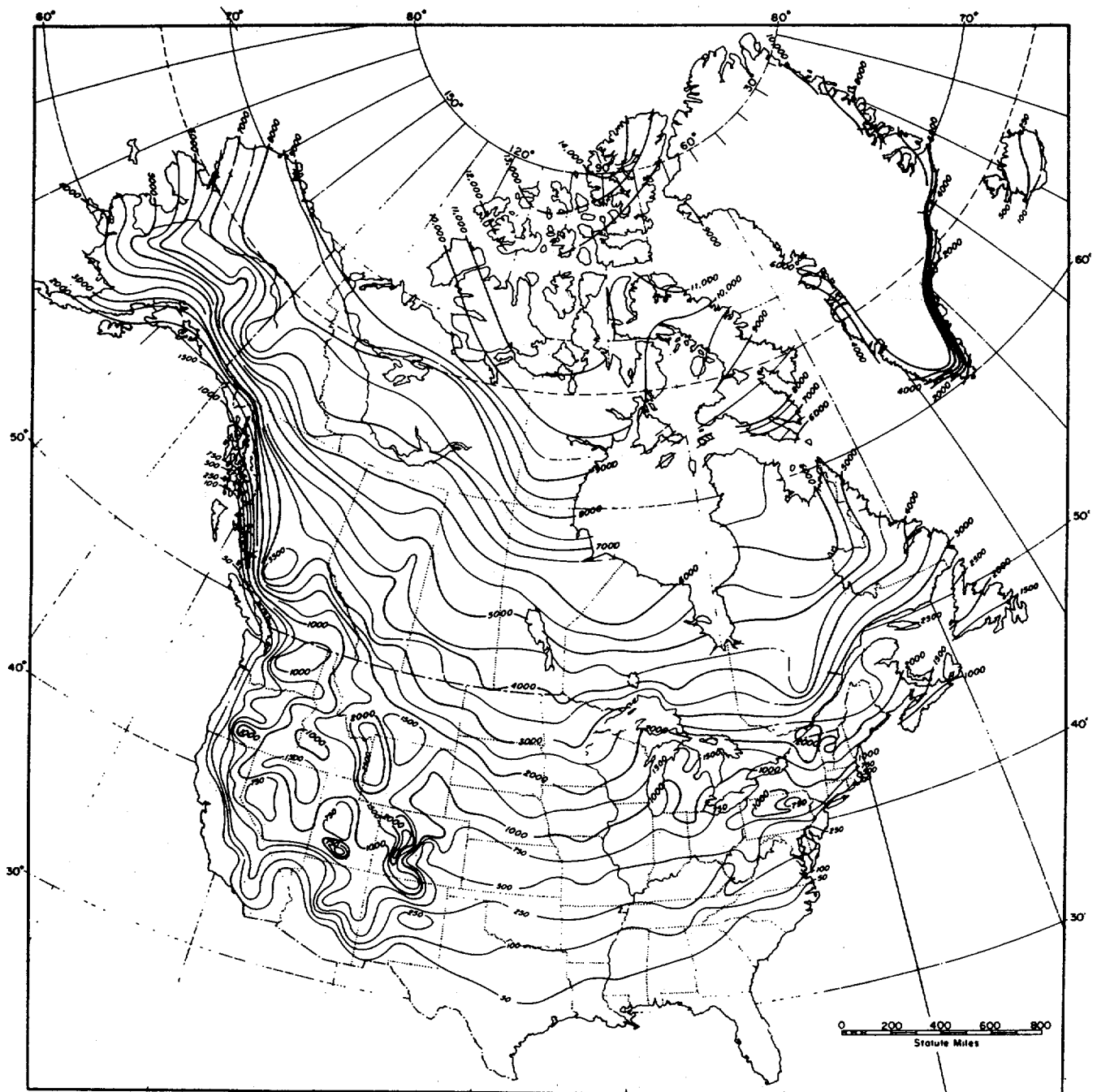

Distribution of design air freezing indices in North America.

Figure 6-13. Design air freezing indexes in North America.

AIR-FREEZING INDEX, Degree-days

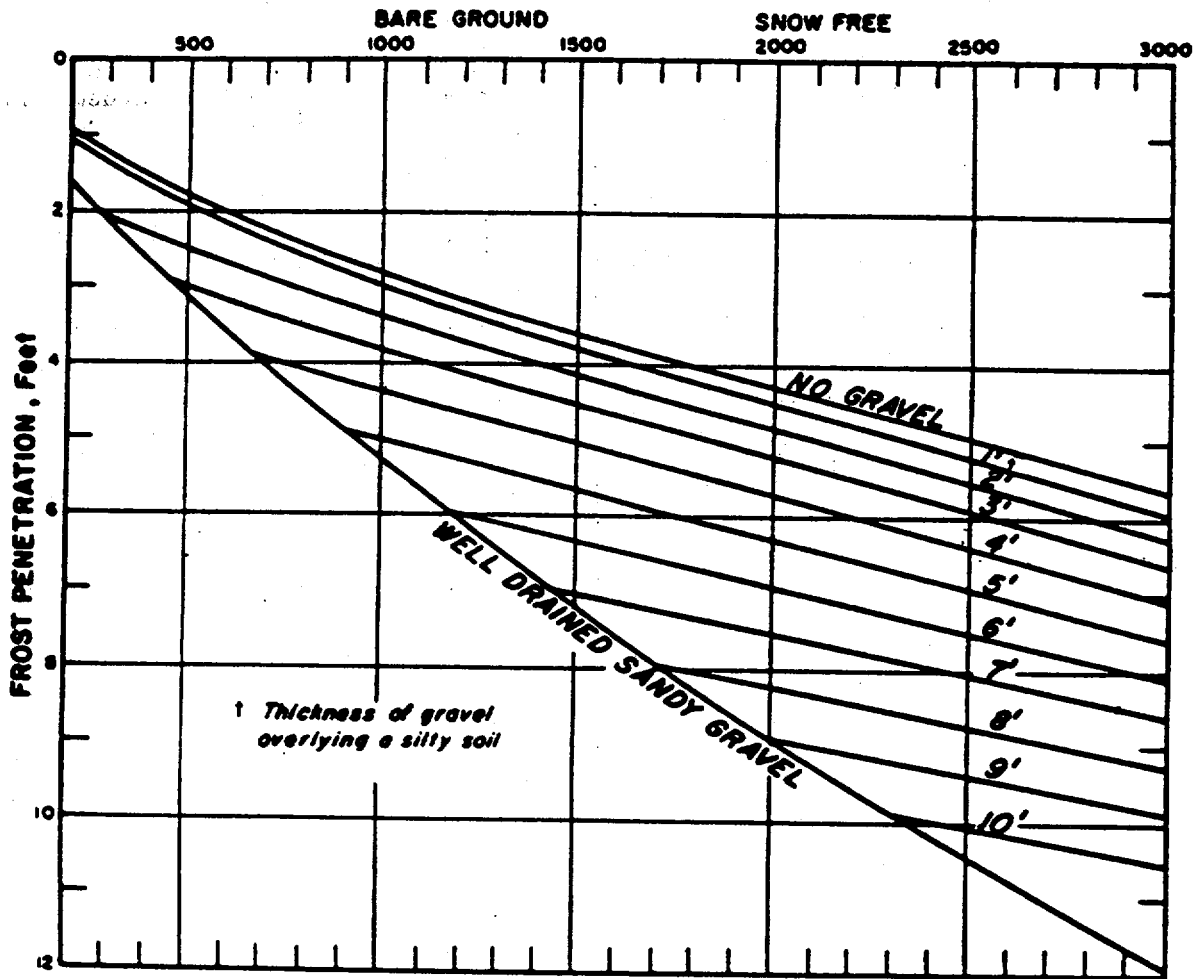

Relationship between air-freezing index frost penetration into a granular soil overlying a fine-grained soil

Figure 6-14. Air freezing index/Surface cover/Frost penetration relationship.

frost penetration value by 0.6. If the resulting number is smaller than the gravel thickness, then there is an adequate amount of ballast and subballast in the cross section. If it is larger, additional ballast and/or sub-ballast should be added and the thickness recalculated.

f. Alternate Design Procedure. An alternate method of designing for the effects of frost is to reduce the effective strength of the soil to compensate for the thaw-weakening period (similar to a reduced-strength pavement design).

g. Methods for Reducing Frost Effects.

(1) Additional Ballast/Sub-ballast. If more than 40 percent of the total frost depth is in the frost susceptible subgrade, nonfrost susceptible material (clean ballast or sub-ballast) must be added to the roadbed.

(2) Geotextiles. Geotextiles can be used to prevent particle migration at the subgrade/subballast interface during the spring thaw. Contamination of an otherwise clean ballast and subballast by subgrade soil can turn a nonfrost susceptible material into a frost susceptible material.

(3) Insulating Material. Frost heaving may be reduced or eliminated by the use of insulating materials. This may be particularly useful in areas with deep seasonal frost which lack nonfrost susceptible soils and in areas with varying subgrade soil conditions that may result in differential heaving. Expanded and extruded polystyrene foam boards are the two most commonly used synthetic insulations. Extruded polystyrene is generally the most popular. In some instances, organic material such as peat, bark, wood chips or timbers and mineral materials such as slag or gravel have also been used. Placement of the insulation can be between the ballast and sub-ballast, sub-ballast and the subgrade or anywhere in between. However, the insulation should be placed deep enough in the cross section to prevent damage by maintenance equipment. In general, a minimum depth of 24 in. is recommended. Results of field and laboratory tests have shown that extruded polystyrene retains its thermal properties and does not absorb a significant amount of moisture if the board is protected from deformation. Therefore, the thickness of the cover above the insulation is usually determined by the vertical stresses caused by the dead and live loads and is limited to 1/5 of the compressive strength of the insulating material. Extruded polystyrene is commercially available in compressive strengths of 40, 60 and 115 psi. Physical properties, available thicknesses and sheet sizes are available from manufacturers specifications. TM 5-852-6/AFR 88-19, chapter 6 provides calculations of frost depth where

insulation is used

h. Transition Zones. A gradual transition is required between areas with significantly different frost heave behavior. The transition distributes differential heave over a distance and thus reduces its detrimental affects. Transitions between cuts and fills and at culvert crossings and bridge approaches are typically 75 to 100 feet long.

i. Construction Procedures. Subgrade will be excavated and scarified to a predetermined depth based on field conditions, and then wind-rowed and bladed to achieve adequate blending. This helps to insure a high degree of uniformity of soil conditions and eliminate any isolated pockets of soil with higher or lower frost susceptibility. It may be necessary to remove isolated pockets of either low or high frost susceptible material. In these cases, the soil should be excavated to the full frost depth and replaced with the surrounding soil. Stones (6-in. in diameter or larger) or large roots must be removed from any fill in the full depth of the frost penetration. This includes any stones encountered during subgrade preparation. Failure to remove these items can result in track roughness as the stones and roots are gradually heaved upward. In rock excavations, positive drainage should be supplied so that no pockets of water are left in the zone of freezing. The irregularity of the isolated pockets may lead to nonuniform heaving. At the transition between cut and fill sections, transition sections should be used as previously discussed. Frequently, rock joints and fractures are full of frost susceptible soil. Rock joints or fractures encountered in the subgrade should be cleaned out to the full depth of frost penetration and these joints replaced with nonfrost susceptible material.

6-7. Drainage.

a. Importance. Although not a component of the track or roadbed, drainage (or lack of it) can have a major impact on track strength and longevity. Without proper drainage, track will fail to perform as designed or intended.

b. Design guidance. TM 5-820-4/AFJMAN 32-1016 will be used for the design and construction of drainage structures, except as modified by the following paragraphs.

c. Side Ditches.

(1) Most commonly, drainage is provided by open ditches running parallel to the track. In terminals and in other level areas, subdrainage or other alternative drainage designs will be required.

(2) To prevent a significant loss of strength in the subgrade, side ditches must provide ample capacity and flow rate. The size of ditches will be based on the expected rainfall runoff and the contribution from other drainage which may empty into the ditches. Guidance for estimating runoff and ditch size may be found in TM 5-820-4.

(3) To provide adequate capacity, side ditches will be designed for a 10-year storm. To provide an adequate flow rate, the minimum gradient for side ditches will be 0.30 percent.

(4) While not a desirable practice, there are some areas where the bottom of the ballast section cannot be installed or raised above the surrounding ground level, and standard side ditches cannot be dug (or would not provide sufficient flow). In these cases, subdrainage will be installed as shown in figure 6-15.

d. Culverts.

(1) The AREA manual provides design criteria and specifications for railroad culverts. AH culvert pipe will conform to current AREA or ASTM recommendations or specifications for culvert pipe under railroads.

(2) A minimum cover of 2.5 ft should be provided from the bottom of the tie to the top of the culvert

6-8. Geotextiles.

a. Application Under Track. Geotextiles are sometimes used under the track to provide for filtration and/or separation of ballast and subgrade or ballast and sub-ballast, or drainage functions. Common locations for the installation of a geotextile under track are:

- (1) Highway-railroad grade crossings.
- (2) Locations with poor subgrade.

(3) When rebuilding track with a history of excessive loss of profile (surface) and frequent track maintenance requirements.

(4) Turnouts. (see fig 6-16.)

(5) Bridge approaches. (see fig 6-17.)

(6) Rail crossings. Recent industry studies have shown that geotextiles have not always been effective under track. Thus, before deciding to install a geotextile, a thorough analysis of the site must be done to assure that a geotextile will accomplish its intended purpose.

b. Material and Installation Specifications. Geotextiles, and their installation, will conform with the specifications in the AREA manual.

c. Drainage Applications. Lighter weight geotextiles are often useful for drainage applications outside of the track structure, especially in subdrainage.

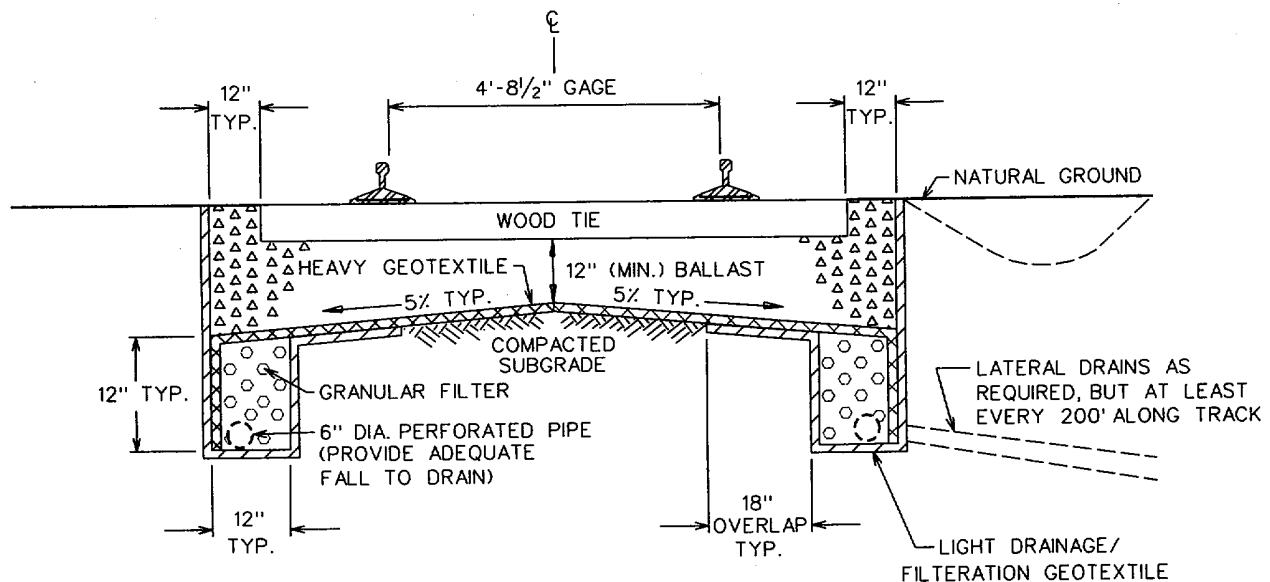

DRAWING NOT TO SCALE

Figure 6-15. Required subdrainage where surrounding natural ground is above bottom of ballast and open side ditches cannot be installed.

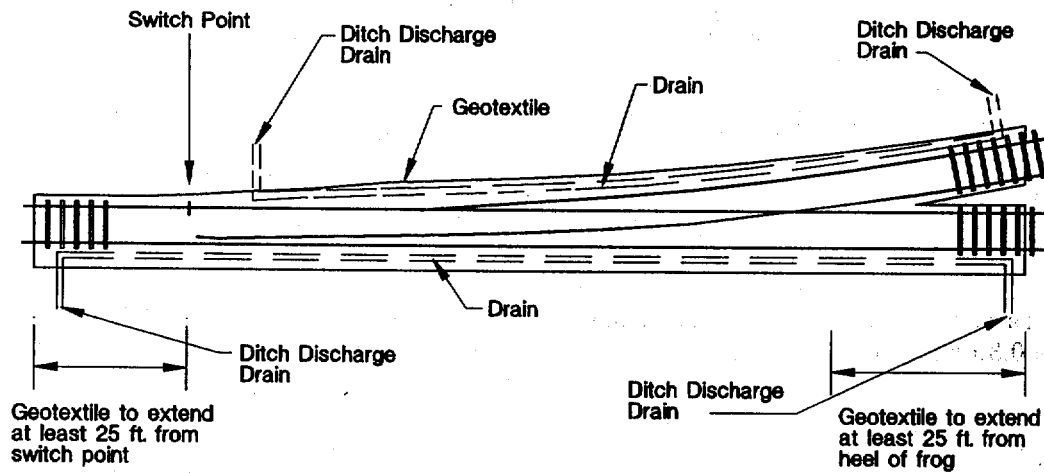

Figure 6-16. Geotextile installation under a turnout.

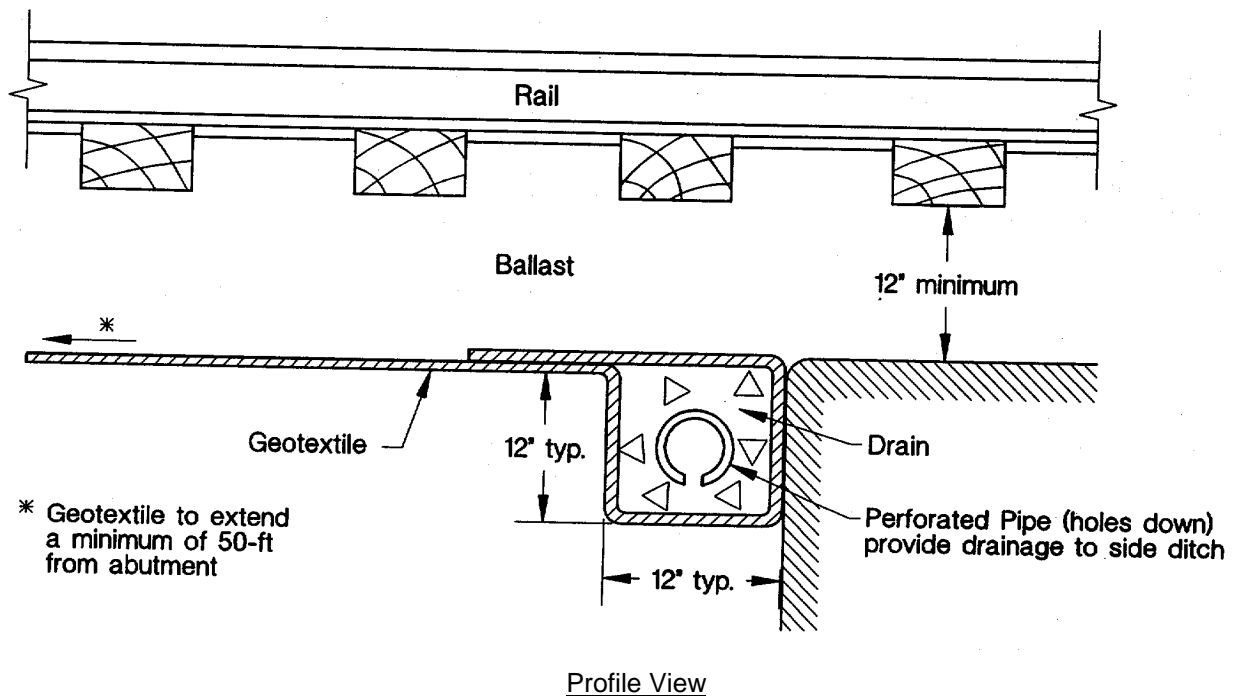

Figure 6-17. Geotextile installation at a bridge abutment.

6-9. Ballast.

a. *Purpose.* Ballast performs four primary functions:

- (1) Distributes wheel loads at reduced pressure to the subgrade.
- (2) Restrains the track laterally and longitudinally.
- (3) Helps maintain track surface.

(4) Allows track structure to drain.

b. *Material Ape.*

(1) As ballast depends on high friction and interlock to be effective in restraining track and must also withstand large loads, ballast must consist of a hard angular crushed rock or crushed slag.

(2) Common rock materials suitable for ballast are granites, traprocks, quartzites, dolomites,

and hard limestones. As limestones degrade, they tend to produce fine particles which cement together, and are thus not the best ballast choice if other hard rock material is economically available. Crushed slag can also vary greatly in quality and suitability for good ballast.

c. Gradation.

(1) Recommended AREA ballast gradations are given in table 6-3. For main running tracks, sizes 3, 4A, and 4 will be used, with 4A or 4 preferred. For loading tracks in terminal areas, size 5 may be used to facilitate easier walking along the cars during loading and unloading operations, but a larger size is preferred for long term track maintenance. AREA ballast gradations 3 and 4 are identical to ASTM C33 gradations 3 and 4, respectively. ASTM C33 gradation 56 is close to AREA no. 5.

(2) For smaller projects, where less than 200 tons of ballast is needed, and where the nearest suppliers do not stock AREA gradations, the following highway gradations may be substituted: CA3 for AREA 3, CA5 for AREA 4 or 4A, and CA7 for AREA 5.

d. Depth.

(1) Appropriate ballast depth will be determined by structural analysis using the computer programs specified in paragraph 6-2. The manual method described in paragraph 6-3 may also be used but is not preferred.

(2) In all cases, the minimum depth of ballast from the bottom of the tie to the subgrade will be 8 in. In most cases, however, main running tracks will require more.

e. Cross Section. Standard ballast shoulder widths and side slopes are shown in figures 6-5

through 6-11. In finished or resurfaced track, the top of ballast may be up to 1 inch below the top of the tie, but never above the top.

6-10. Sub-Ballast.

a. Purpose. Sub-ballast is a layer of material between the top ballast and subgrade with a gradation finer than the top ballast and coarser than the subgrade. Often cheaper than top ballast, it can be used to reduce total ballast cost or to provide a filter layer between the top ballast and a fine-grained subgrade. A sub-ballast layer is shown in figures 6-6, 6-8, 6-9, and 6-11.

b. Application. A sub-ballast layer is recommended for most new construction. In addition to providing a filter to keep subgrade particles from working up into and fouling the ballast, it provides a good mat to distribute loads from the ballast and prevents ballast particles from being pushed into the subgrade. A sub-ballast layer is required whenever:

(1) The subgrade contains 85% or more (by weight) of silt and clay sized particles, or:

(2) The subgrade material has a liquid limit greater than 50 and a plasticity index greater than 20.

b. Material. Sub-ballast should be a hard, angular, non-cementing material, primarily of sand sized particles.

c. Gradation.

(1) To function well as a filter layer, the sub-ballast particles should range in size from the smallest ballast particles to the largest subgrade particles.

Table 6-3. Recommended Ballast Gradations.

Size No.	Nominal Size Square Opening (in.)	Amounts Finer Than Each Sieve (Square Opening)							
		Percent by Weight							
		2-1/2in.	2 in.	1-1/2in.	1 in.	3/4 in.	1/2 in.	3/8 in.	No. 4
3	2 to 1	100	95-100	35-70	0-15		0-5		
4A	2 to 3/4	100	90-100	60-90	10-35	0-10		0-3	
4	1-1/2 to 3/4		100	90-100	20-55	0-15		0-5	
5	1 to 3/8			100	90-100	40-75	15-35	0-15	0-5

(2) Over a clay or silty clay, with greater than 85% passing the no. 200 sieve, the following gradation is recommended:

Seive Size	1/2"	3/8"	#4	#10	#20	#40	#100	#200
Percent Passing	100	90	80	70	50	40	20	10.

This gradation can be approximated by specifying the middle to finer side of the range for ASTM D 1241 gradation D.

(3) Over a subgrade with more than 15% larger than no. 200, such as the middle to coarser side of the range for ASTM D 1241 gradation D.

d. Depth.

(1) During structural analysis, the subballast layer is considered as part of the total ballast depth.

(2) A sub-ballast layer may comprise up to 40% of the total ballast depth on main running tracks and up to 50% on auxiliary and terminal tracks.

(3) When used, the minimum sub-ballast thickness will be 4 inches with a minimum total ballast depth of 10 inches.

6-11. Ties and Tie Spacing.

a. Material.

(1) Ties will be made of wood and will meet the requirements in the AREA manual. The recommended species of wood for cross ties are:

<i>Hardwoods</i>	<i>Softwoods</i>
Ash	Douglas Fir
Beech	Pine
Hickory	Spruce
Red Oak	
White Oak	

(2) Strictly defined, hardwood and softwood refer to a type of tree and not the harness or density of the wood. However, the hardwoods listed above are denser and generally more durable than the listed softwoods and thus usually more desirable for ties. While softwoods are sometimes preferred on open deck bridges to help absorb impact, they are not recommended for use in turnouts or in sharp curves (over 8 degrees) where the better spike-holding ability of the denser woods is needed.

(3) Hardwood ties are often sold in species groups such as mixed hardwoods or oak. The mixed hardwoods may comprise, for example, 40% oak and 60% assorted hardwoods, including gum. Gum is not a preferred species, but is commonly used. The oak group is usually a mix of red and white oak and typically costs

more than the mixed hardwoods.

(4) For track with annual traffic volumes of 5 MGT or less, as is common at military installations, ties are more likely to fail from decay rather than mechanical wear or loss of spike-holding ability. In such cases, tie selection should lean toward available species which readily accept deeply penetrating preservative treatment. Information from the engineering department of the serving commercial carrier, from regional tie suppliers, and from local experience should help in selecting the most appropriate ties.

b. Cross Section and Length.

(1) The two common cross sectional sizes for track ties are 7 inches thick by 9 inches wide or 6 inches thick by 8 inches wide.

(2) 7x9 ties are recommended for areas with higher traffic volumes and wheel loads as well as in turnouts and in road crossings.

(3) Track ties are commonly produced in 8.5 or 9-foot lengths. The 8.5-foot length will be used when most conveniently available.

(4) Ties for turnouts vary from 9 to 17 feet long and will be ordered as indicated in table 6-5.

c. Treatment.

(1) All wood ties will be pressure treated with preservative as specified below.

(2) The preferred preservative for ties is a creosote-coal tar solution (60/40) as specified in AWPAs standard P2.

(3) For ties used west of the Mississippi River, where attacked by organisms such as fungi and termites is generally not as severe, a creosote petroleum solution (50/50) as specified by AWPAs standard P3- may be used.

d. Anti-splitting Devices. To reduce the tendency of wood to split, anti-splitting devices are often applied to the ends of ties. Anti-splitting devices are recommended for turnout ties but may be specified for standard track ties. Of the two general types, as shown in figure 6-18, the nail plates are more effective and thus preferred.

e. Preboring. Once common practice, the preboring of spike holes is no longer recommended.

f. Tie Spacing. The center-to-center distance between adjacent ties will usually range from 19.5 to 22 inches, with a minimum allowable of 18 inches and a maximum of 24. For auxiliary and loading tracks, a 21 to 23-inch spacing will often suffice. Tie spacing will be specified after a structural analysis has been performed.

g. Concrete and Other Non-Standard Ties.

(1) Concrete ties are used by some commercial railroads, particularly on lines with the heaviest traffic volumes and in areas with numerous curves. Where used, concrete ties are in track with welded rail and solidly supported with deep ballast sections. Concrete

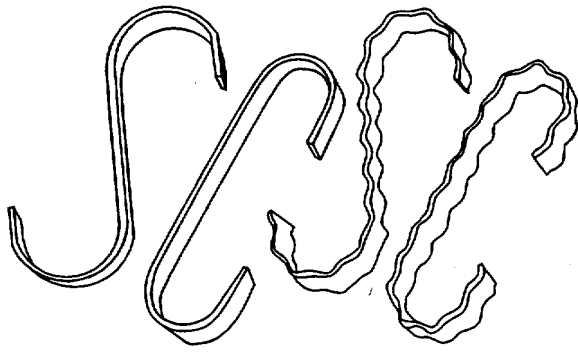

a. S and C Irons

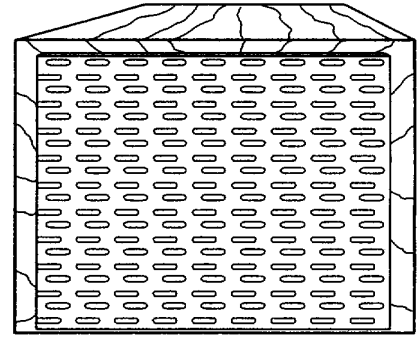

b. Nail Plate

Figure 6-18. Anti-Splitting Devices for Tie Ends.

ties are usually not economical on lighter traffic lines, and are usually not suitable for use with jointed rail or in track of lighter construction. Also, concrete ties cannot be successfully mixed with wood ties. Thus, concrete ties are not recommended for general use in military track.

(2) The use of concrete ties for certain special applications may be cost effective. The economic benefit of these installations must be thoroughly investigated prior to the selection of concrete ties.

(3) Research and development continues on ties made with alternative materials and of hybrid construction. None have yet proven economical for routine, general purpose use.

6-12. Rail.

a. Section designation. Rail is rolled into different sizes (dimensions) and shapes commonly referred to as "weight" and "section." The weight of a rail is based on how much a rail weighs in lbs per yd of length. The section refers to the cross sectional shape of the rail.

b. Selection Criteria. Selection of a rail section will be done only after a structural analysis has been performed. Designers will determine structural requirements as well as cost and availability of rail sections before a final selection is made.

c. Recommended New Rail Sections.

(1) Weights and sections recommended for new rail purchases are: 115RE, 132RE, 133RE, and 136RE, with 115RE preferred. These are the standard sections recommended by the AREA and should be available for many years.

(2) Rail may be purchased in either 39 ft or 80 ft lengths. Rail 80 ft long has the advantage of

reducing the number of joints to half that for 39 ft rail. For small purchases where the rail may be transported by truck 39 ft lengths may be more cost effective.

d. Relay (Secondhand) Rail.

(1) Secondhand rail which meets the specifications in table 6-4 either as is or after cropping off the ends, may be used for rehabilitation or new construction. Before selecting relay rail, the cost, condition, and availability of matching joint bars and tie plates must be investigated.

(2) Recommended relay rail sections are: 100ARA-B, 112RE, 115RE, 130RE, 132RE, 133RE, and 136RE.

(3) Relay rail should be selected to limit the number of different rail weights and sections within the track network. For a given weight, the section and joint drilling pattern (bolt hole size and spacing) should also be consistent.

(4) Due to the varying market for relay rail it may be beneficial to allow the contractor an option to provide an acceptable rail section. Selection should be limited to those sections which are sufficiently plentiful to supply future maintenance purchase requirements: rail, joint bars, frogs and other turnout parts.

e. Lightweight Rail.

(1) Lightweight rail weighs less than 90 lbs per yd. These weights are no longer manufactured and are only available as secondhand.

(2) For main running tracks, rail weights less than 90 lbs per yd will not be used. Rail weighing 75 lbs per yd to 85 lbs per yd may be adequate for terminal and auxiliary tracks with light use, depending upon support conditions. A structural evaluation is necessary to determine the adequacy of these rail weights. Rail not

Table 6-4. Dimension and Surface Specifications for Relay (Secondhand) Rail.

Length	<ul style="list-style-type: none"> - Standard 33 ft or 39 ft lengths. - 90% of lot 33 ft or longer. - Not more than 10% of lot between 27 ft and 33 ft.
Vertical Wear	<ul style="list-style-type: none"> - No rail shorter than 27 ft. - Average top wear 1/8 in. or less with maximum at any one location of 5/32 in.
Side Wear	Maximum of 1/8 in., with wear on one side only.
Lip or Overflow	<ul style="list-style-type: none"> - Maximum of 1/16 in.
Engine Burns	<ul style="list-style-type: none"> - Maximum of 1/2 in. diameter (or 1/4 in. wide by 1/2 in. long) and 1/32 in. deep. - Maximum of six engine burns per rail. - Engine burns on no more than 25% of the lot.
End Batter and Chipping	<ul style="list-style-type: none"> - Maximum of 1/8 in. when measured 1/2 in. from the rail end with an 18 in. straightedge.
Running Surface Damage	<ul style="list-style-type: none"> - Maximum of 1/4 in. wide by 1/2 in. long and 1/32 in. deep. - Flat spots are not permitted on the rail head.
Defects Not Permitted	<ul style="list-style-type: none"> - Bolt hole cracks or breaks, broken base, crushed head, detail or engine burn fractures, head-web separation, piping, horizontal or vertical split head, torch cuts or flame gouges, compound or transverse fissures, pitting.
Condition and Appearance	<p>Rail must be:</p> <ul style="list-style-type: none"> - Free from obvious defects. - Clean in appearance. - Straight in line and surface and free from kinks. - Free from base defects such as plate wear, spike notches, pitting, and flame-gouging.

adequate to support the desired wheel loads should be replaced.

f. Continuous Welded Rail (CWR).

(1) Continuous welded rail (CWR) is strings of standard rail welded together either in a rail plant or by field welding after installation. CWR is commonly used on commercial railroads and is beneficial in reducing maintenance costs due to rail joints.

(2) CWR is not recommended for general use on military track as it requires a larger ballast section to provide sufficient track restraint, needs more rail anchors to restrain longitudinal rail expansion, is more subject to buckling in hotter weather and pull-aparts during colder weather, and has a higher initial installation cost. If conveniently available, short strings (less than 200 feet) may be appropriate for wide road crossings or track in paved areas.

g. Field Welds.

(1) It is recommended that rail through road crossings and for 20 ft on either side of crossings be welded to eliminate joints in these areas. Likewise, field welding should be considered for rail placed in confined loading areas, adjacent to warehouse loading docks, and in other areas where maintenance access to rail joints would be difficult.

(2) Rail welding may only be accomplished with special thermite welding kits designed for this purpose and by people with the necessary training and experience in welding rail. Where many welds are to be done, some specialized contractors have truck-mounted electric welding units designed for this purpose.

h. Salvaging Rail. During track reconstruction the existing rail and other track materials can often be salvaged for use at other locations on the installation, stockpiled for future construction projects or sold on the open market as used material. Lightweight rail, defective rail, and other track materials not suitable for use in track reconstruction on the installation or for resale on the open market should be disposed of as scrap or reroll material.

6-13. Other Track Material.

a. Definition. Tie plates, joint bars, bolts, spikes and other miscellaneous hardware used in track construction are commonly referred to as other track materials (OTM).

b. Tie Plates.

(1) Tie plates vary in length and width. Most sizes are suitable, as long as the spike hole punching (or distance between the shoulders-for double shoulder plates) matches the width of the

rail base. For double shoulder tie plates, the distance between the shoulders will be at most 1/8 inch larger than the rail base width. On single shoulder plates, the spike holes on the gage side (opposite the shoulder) must keep the inside face of the spike within 1/8 inch of the rail base when the opposite edge of the base is against the shoulder. (see fig 6-19(a) and (b).)

(2) Either single or double shoulder tie plates can be used.

(3) Within a given length of track, tie plates of different lengths and widths may be used, and single shoulder plates may be mixed with double shoulder plates. However, plates with different cants (i.e. those with level rail seats and those with a 1:40 slope) will not be mixed. Tie plates with a 1:40 cant are preferred.

(4) Secondhand plates which are not bent, have not lost much material due to corrosion, and otherwise meet the above requirements, are acceptable.

c. Spikes. On tangent track and on curves up to 4 degrees, one spike on the gage and field side of each rail will be used (a total of 4 spikes in each tie). On curves greater than 4 degrees, one spike on the field side and two spikes on the gage side of each rail will be used (a total of 6 spikes in each tie).

d. Rail Joints and Joint Bars.

(1) Either four-hole (24-inch) or six-hole 36-inch) joint bars may be used for rail joints.

(2) Standard and compromise joint bars will be properly factory designed and constructed and will be of the size, shape and punching pattern to fit the rail being joined. New joint bars will meet "Specifications for High Carbon Steel Joint Bars" or "Specifications for Quenched Carbon Steel Joint Bars and Forged Compromise Joint Bars" in chapter 4, part 2 of the AREA Manual and joint bar assemblies in chapter 4, part 1 of the AREA manual. Compromise joints will be specified as indicated in AREA Plan 700B.

(3) Secondhand joint bars may be used on secondhand rail if not bent, cracked, excessively corroded, or otherwise defective. Secondhand joint bars will not be used on new rail.

(4) Insulated joints required to isolate signal currents. for road crossing warning devices may be either the field-applied type or prefabricated (glued) type. Special insulated tie plates are also required.

(5) It is recommended that rail joints be welded where located in road crossings, paved areas, or at any location where access to the joint is restricted.

e. Track Bolts, Nuts, and Spring Washers.

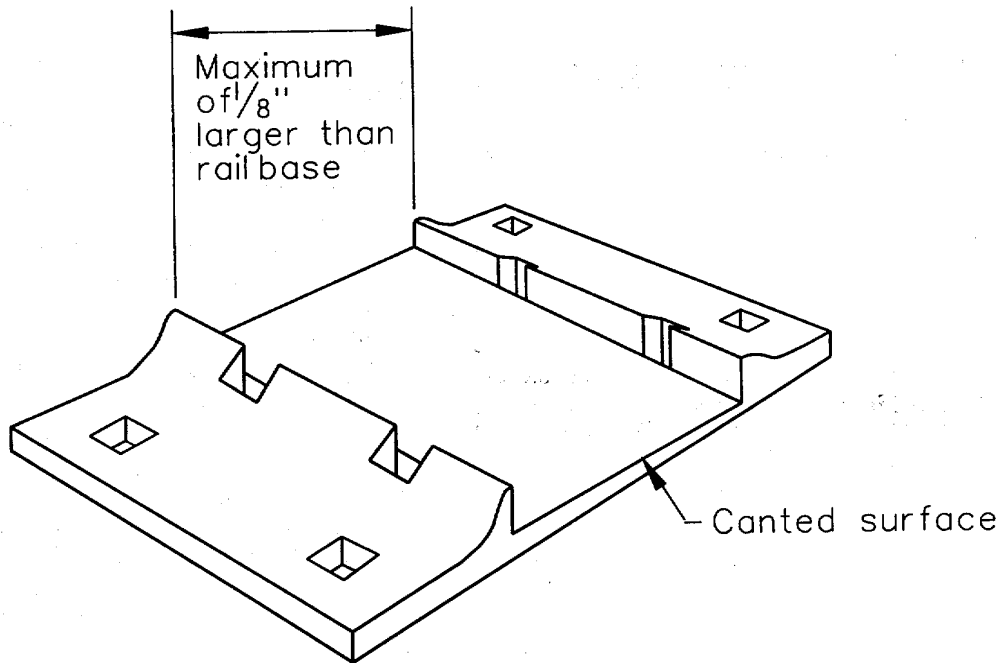

A. Double shoulder tie plate with 1:40 cant

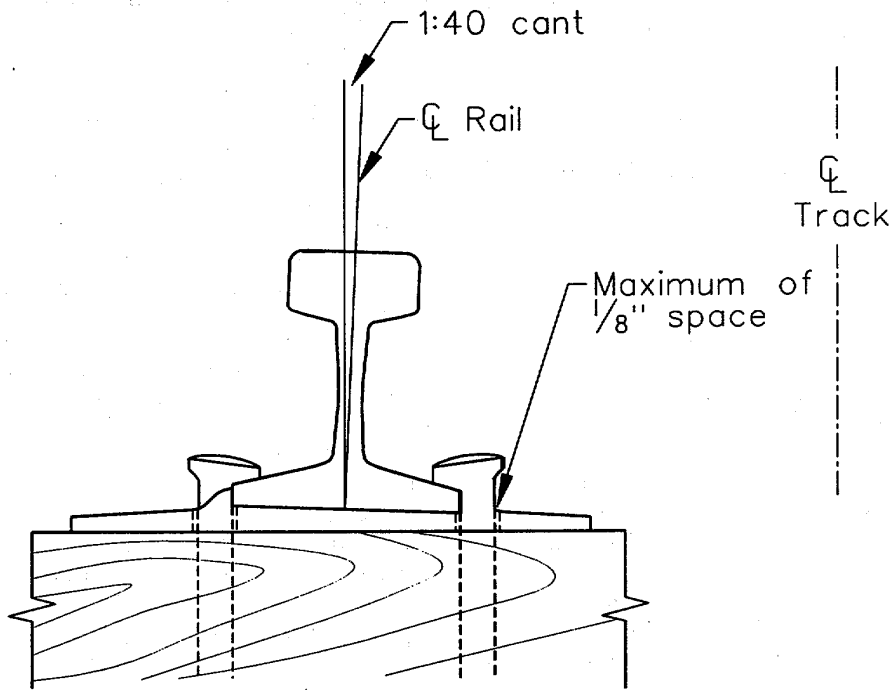

B. Single shoulder tie plate with 1:40 cant

Figure 6-19. Tie Plates.

(1) Track bolts, nuts, and spring washers will conform to the specifications in chapter 4, parts 1 and 2, of the AREA manual.

(2) Common bolt diameters for different rail weights are as follows:

Bolt Diameter, in.	Rail Weights, lbs per yd
3/4	60 to 75
7/8	70 to 90
1	90 to 130
PIA	131 to 140

f. Rail Anchors.

(1) Rail anchors restrain longitudinal rail movement and should be used on main running tracks in the quantity and arrangement diagramed

in figure 6-20, as a minimum. Additional anchors may be required on track with grades steeper than 0.5%, and where combinations of traffic volume, speed, and curvature indicate a need.

(2) When anchors are used, each tie which is anchored will have 4 anchors applied per tie (box anchored), as shown in figure 6-20.

(3) Either type of anchor, spring or drive-on (shown in figure 621), may be used. Drive-on anchors have the advantage of being easier to apply and remove manually, and do not require a special anchor wrench, as do spring anchors. It is possible, though, to over-drive a drive-on anchor, causing it to lose its ability to tightly grip the rail base.

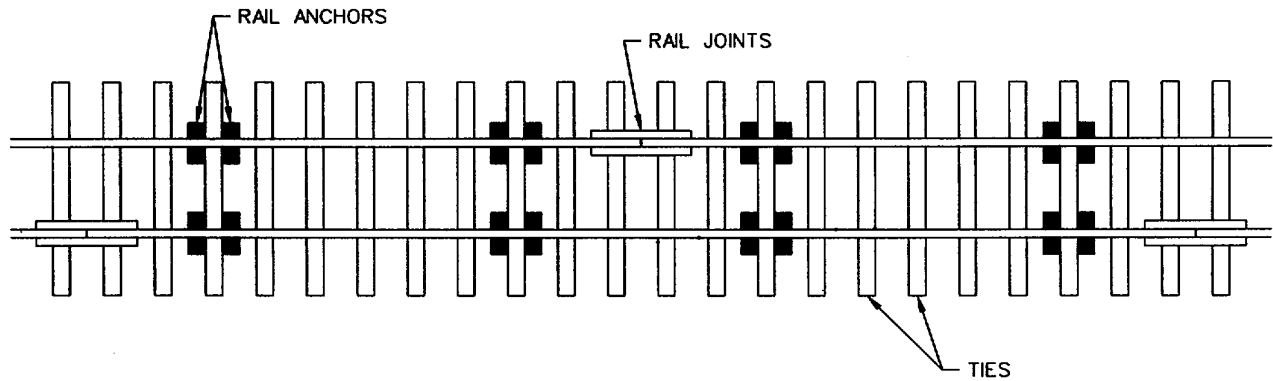

A. Lower Traffic (Standard)

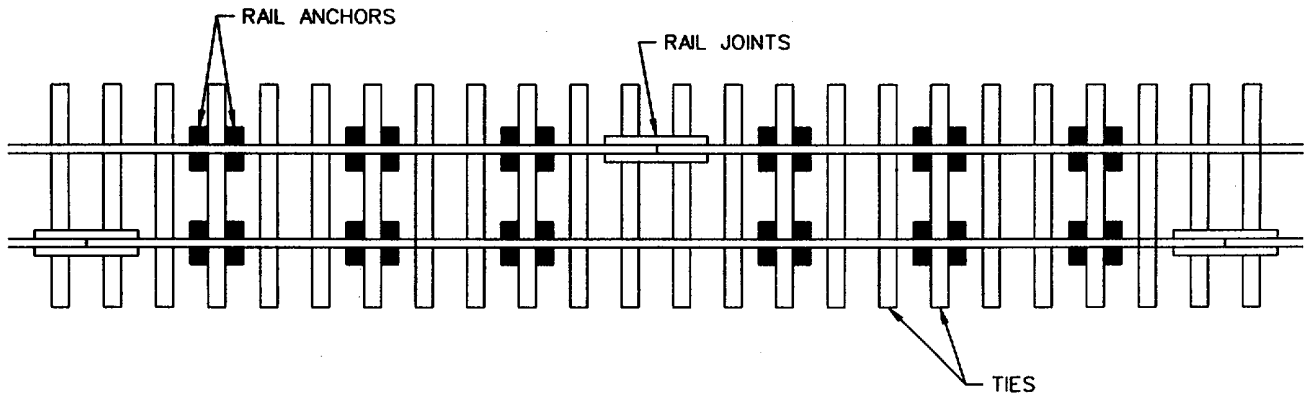

B. Large Traffic Volumes or on a Grade

Figure 6-20. Recommended Minimum Rail Anchor Application.

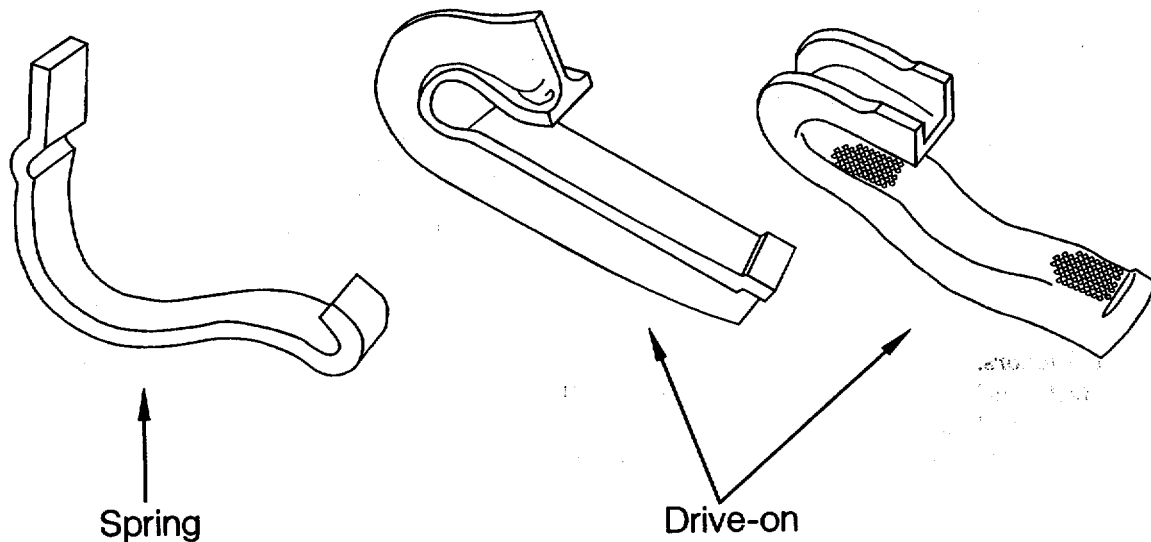

Figure 6-21. Rail Anchors.

(4) Rail anchors will not be used across deck bridges. Instead, for two rail lengths off end of the bridge, every third tie should be anchored. A similar arrangement should be at rail crossings, as shown in figure 6-22. Rail anchors should be applied at the normal designated pattern across ballast deck bridges.

g. Gage Rods.

(1) Gage rods are sometimes specified for sharp curves (over 8 degrees) where difficult holding gage is anticipated. Where used on sharp curves, two to four rods should be installed rail length.

(2) The general use of gage rods is not encouraged and should be reserved for special or unusual cases.

6-14. Turnouts and Crossovers.

a. Description. Turnouts are designed to divert trains from one track to another. Two turn form a crossover when used together to allow passage of trains between parallel tracks. The general arrangement of turnouts and crossovers is shown in figure 6-23. The main parts of a turnout are shown in figure 6-24. For additional switch detail see AREA Plans 190, 220, and 221.

b. Design and Selection.

(1) The main design decisions for turnouts are the direction in which the turnout will diverge (as shown in fig 6-23), and the angle of the frog (or frog number), which determines how sharply the turnout diverges (and also designates the size of the turnout). These and other geometric aspects are covered in chapter 7. Recommended choice for different designs and materials of specific turnout parts are covered below.

(2) Once turnout geometry has been determined from chapter 7, the designer will specify the desired turnout by selecting: a switch, a frog, and guard rails, if needed, from the appropriate AREA plans; the turnout (or crossover) tie set from table 6-5; and the amount of rail needed to complete the turnout (connect the switch and frog) from AREA Plan 910 or 911. Guidance on the selection of these items and other turnout hardware is given below.

(3) All materials used within the limits of a turnout will be factory designed and constructed, per of the proper type and size, and not be flame cut or otherwise altered in the field.

c. Switches and Switch Points.

(1) The standard switch for use on military track is the 16'6" switch with graduated risers, as shown in AREA Plan 112. The detailed specification for this switch is given in the notes in the upper right corner of plan. In most cases, the specification will be for a 112E or 112F (noninsulated hand throw-rigid braces), or if adjustable braces are desired, specification 112A or 112B-omit insulation (Note 2(e)), if the switch is not within a signal circuit (as near crossings with warning lights or gates). Shorter or longer switches may be used, as needed, but switches shorter than 15 feet are not recommended.

(2) In locations where traffic conditions may cause excessive wear on the tapered ends of the switch point, the use of alloyed steel (or hardened) switch points is recommended (AREA Plan 220).

(3) The use of spring switches is not recommended on Army and Air Force track.

d. Switch Clips. Either the adjustable side jaw clip or the adjustable transit clip, as shown at the top of AREA Plan 222, are suitable. The slanted row of holes in the clip provides adjustment in switch rod length ranging

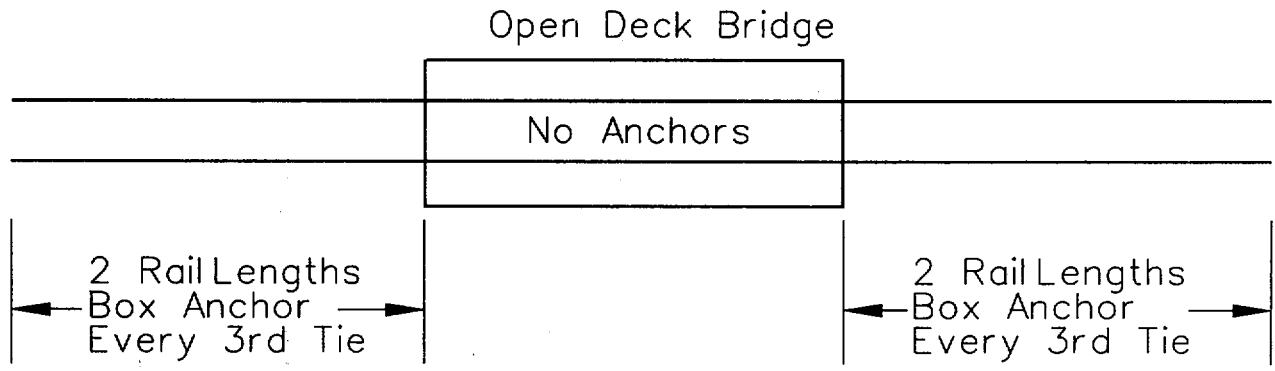

A. Anchoring at Open Deck Bridges

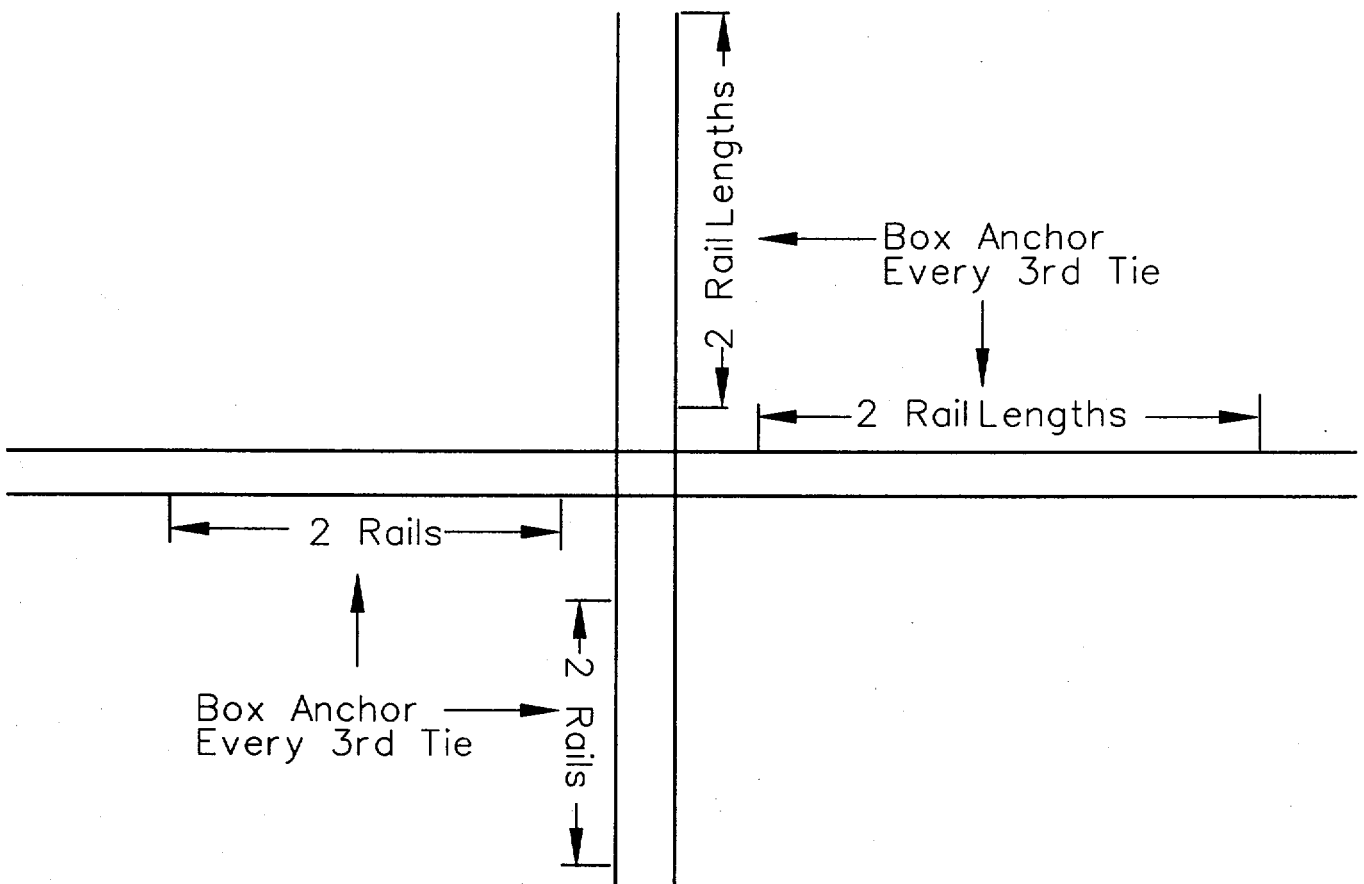

B. Anchoring at Rail Crossings

Figure 6-22. Rail Anchor Applications at Open Deck Bridges and Rail Crossings.

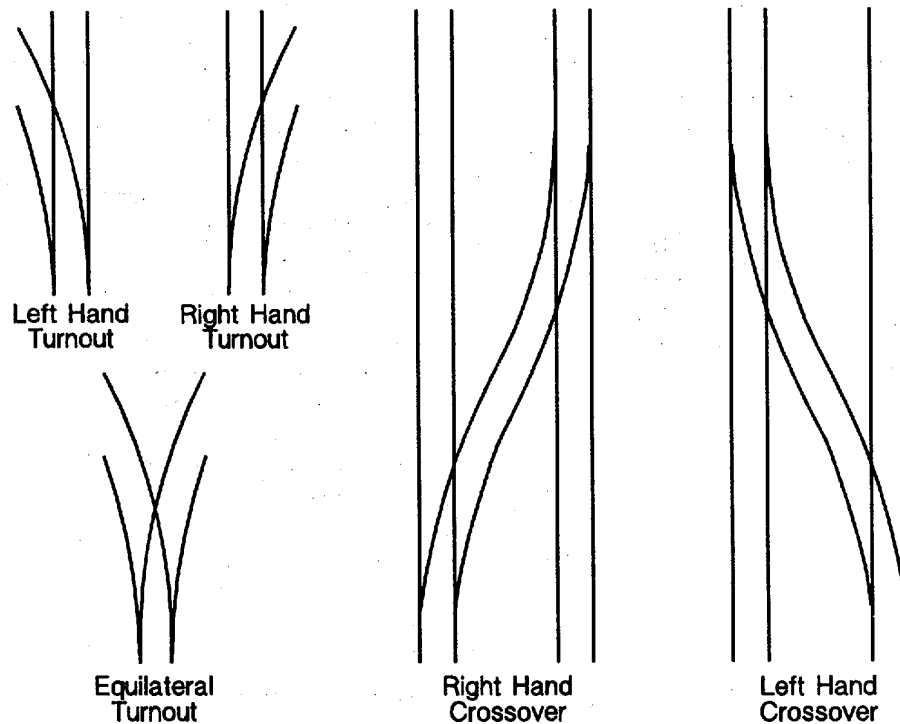

Figure 6-23. General Arrangement of Turnouts and Crossovers.

from 1/8 in. to 1/2 in., effected by moving the bolt from one hole to another.

e. Rail Braces. The rail braces which support the outside of the stock rails may be either the rigid or adjustable type. In most cases rigid braces will suffice, but where movements in both directions through the turnout may be frequent and under heavy loads, the adjustable braces are recommended.

f. Switch Stands and Lever Latches. Ground throw (low) switch stands are preferred, especially in terminal areas, while high stands may be preferred in more remote areas at the ends of passing sidings or where routes diverge. Many variations of stands are available and most are suitable, however, any stand selected should have a provision for the throw lever to lock or latch solidly in place. For switches in more remote areas, a switch point lock and/or lever lock may be desirable.

g. Frogs and Guard Rails.

(1) The solid manganese, self-guarded type frog, as shown in AREA Plans 641 and 691 (Section B-B), is preferred for the slower speed operations most common at military installations. Self-guarded frogs simplify turnout construction by not requiring separate guard rails opposite each side of the frog.

(2) Rail bound manganese (RBM) frogs, as shown in AREA Plan 600, may be used on heavy traffic lines where the traffic is approximately equal on both sides of the frog. This type of frog is most desirable for long turnouts (size 15 or above) since manganese steel is especially suited to the thin long points and requires comparatively little maintenance.

(3) Bolted rigid frogs, as shown in AREA Plan 320, can be used at any location on military installations, however, when new frogs are required, the two choices above are preferred.

(4) Spring rail frogs will not be used on Army and Air Force installations.

(5) Frogs are secured to ties with a set of hook plates, as shown in AREA Plan 241.

(6) When not using self-guarded frogs, guard rails will be specified to match the frog size, as listed in Note 2A of AREA Plan 502. Guard rails of the type in AREA Plans 504 or 510 may be used.

h. Stock Rails and Closure Rails.

(1) Enough rail to make up the straight and curved stock rails and closure rails must be supplied, as indicated in AREA Plan 910 or 911. This amount will approximately equal twice the actual lead (Column 4) plus the closure distances (Columns 5 and 6).

(2) All rail within the limits of a new or secondhand turnout will be of the same weight and

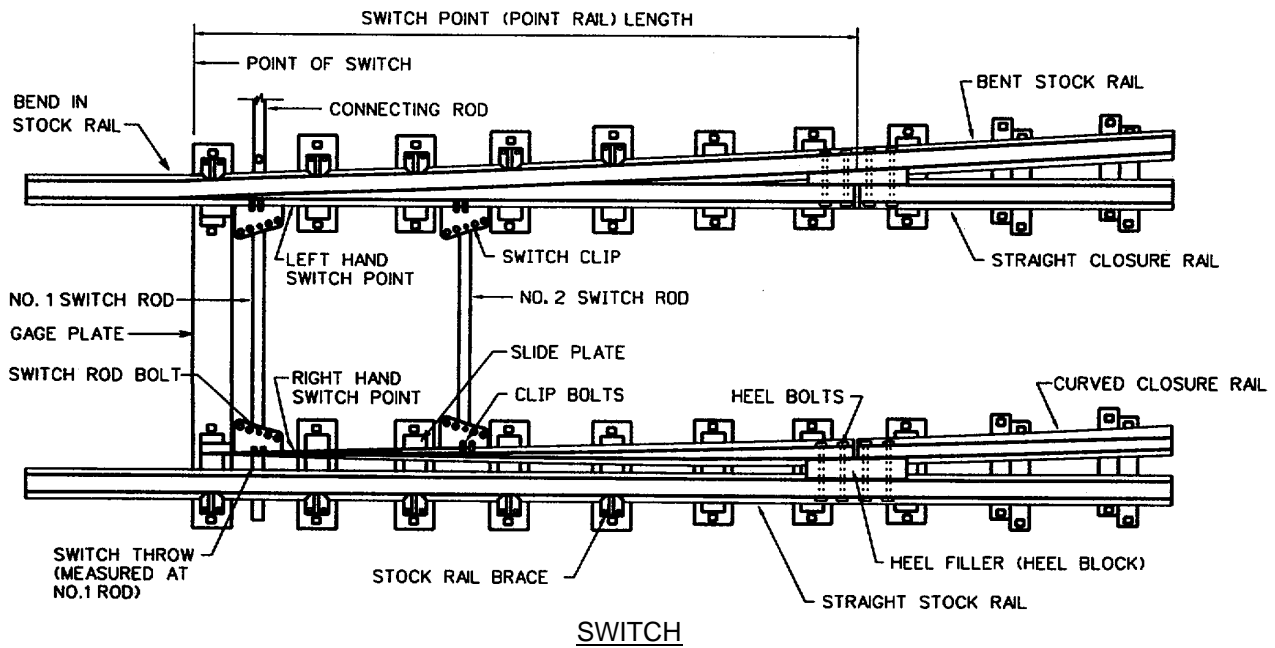
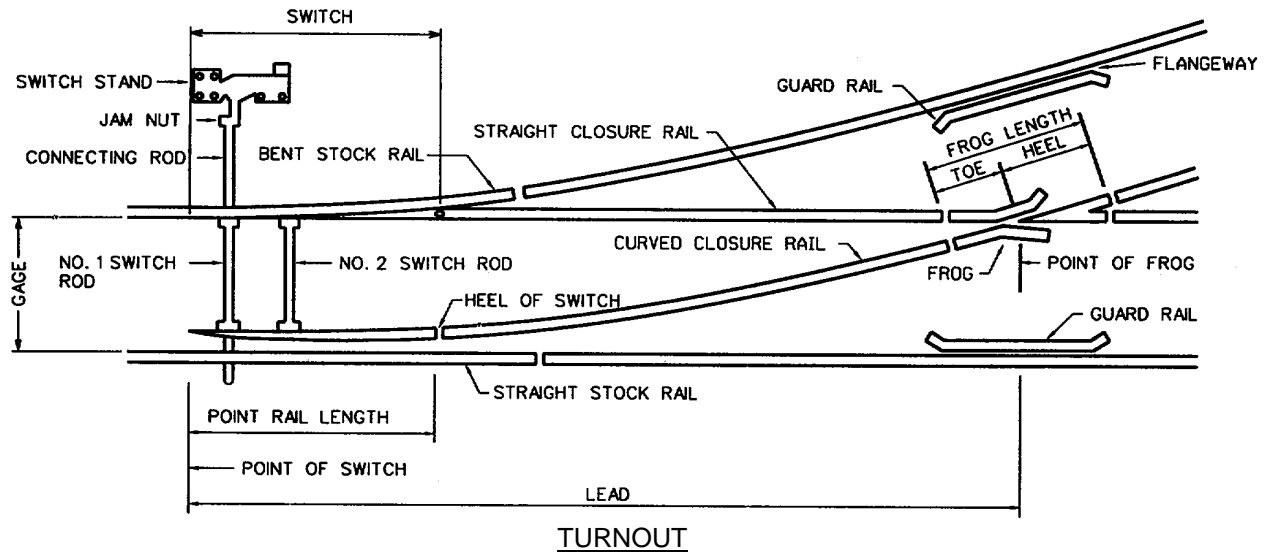

Figure 6-24. Parts of a Turnout.

and section and should match the rails on the main and diverging tracks. Compromise joints are not permitted within the limits of a turnout.

(3) Where new switch points are specified with relay closure rail, a check must be made to assure that the top and gage side of the points and closure rails match at the heel joint.

(4) When turnouts will be rebuilt, and both new and relay rail will be available on the project, it is recommended that new rail be used to reconstruct the turnouts; this will avoid the potential problem of rail contour mismatch at the switch heel joints.

i. Switch lies.

(1) The make-up of switch tie sets and cross-over sets will be determined from table 6-5.

(2) 7" x 9" hardwood ties will be used for turnouts.

(3) Switch ties will meet the material and treatment specifications for standard track ties covered in section 6-11.

6-15. Road Crossings.

a. Design Steps.

(1) The main steps in designing a road crossing are determining the geometric layout, selecting the crossing surface, designing the drainage, designing the track section, and determining the appropriate protection. Crossing surfaces, drainage, track, and crossing protection are covered below. Some geometric design issues are covered in chapter 7.

b. Crossing Surfaces.

(1) Seven standard crossing types are listed in table 6-6, with cross sections and design details shown in figures 6-25 through 6-31.

(2) The following should be considered in selecting an appropriate road crossing surface:

- (a) Vehicle traffic-volume, type and speed.
- (b) Road use-road or street.
- (c) Use by industrial traffic or special vehicles.
- (d) Railroad traffic-volume, type and speed.
- (e) Accident history for existing crossings where the crossing surface may have contributed to the accident.
- (f) Cost-initial construction cost, replacement cost and maintenance cost.
- (g) Expected service life.

(3) Type 1A crossings are intended for short-term use where vehicles must cross the track and where a permanent crossing is not required. A type 1A crossing is constructed with a minimum amount of effort in keeping with its function and life expectancy.

(4) In table 6-6, type 4A crossings are listed under light traffic densities for both low and high speeds. While not normally recommended for light duty roads, these crossings may be beneficial in industrial (warehouse) areas where the track must be encased in pavement.

Table 6-5. Switch ties for Standard Turnouts.

Frog #	Switch Point Length	Lead Distance	Number of Ties of Each Length								Total Ties
			9'	10'	11'	12'	13'	14'	15'	16'	
7	16-1/2	62'-1"	7	13	6	5	3	4	6	6	50
8	16-1/2	68'	7	13	6	6	4	5	7	6	54
9	16-1/2	72'-3.5"	7	13	7	7	6	5	8	6	59
10	16-1/2	78'-9"	7	15	8	7	6	6	7	8	64
11	22	91'-10.25"	10	17	9	8	8	6	8	8	74
12	22	96'-8"	10	17	10	9	8	7	9	9	79
14	22	107'-0.75"	10	17	13	10	9	8	11	11	89
15	30	126'-4.5"	15	21	15	11	10	9	11	12	104
16	30	131'-4"	15	21	15	12	12	11	10	12	108
18	30	140'-11.5"	15	24	17	12	11	11	13	14	117
20	30	151'-11.5"	15	26	19	12	12	11	15	16	125

Note: Each tie set includes 2 - 15' ties for headblocks (which hold the switch stand)

Table 6-6. Recommended Crossing Surfaces.

		Recommended Crossing Surfaces					
Traffic Category:	Light		Medium		Heavy		
Vehicle Speed:	<=35	>35	<=35	>35	<=35	>35	
Surface Type	1A	1B	2	3	3	3	
	1B	2	3	4A	4A	4A	
	2	3	4A	4B	4B	4B	
	3	4A +	4B	5	5	5	
	4A +	4B+					

Surface Type Key:

- 1A Gravel (Semi-Permanent)
- 1B Gravel with Timber Headers
- 2 Timber
- 3 Asphalt
- 4A Concrete: Cast-in-Place
- 4B Concrete: Precast Panels/Systems
- 5 Elastomeric System

Traffic Category	Average Daily Traffic		Design Hourly Volume	
	Road (Open Area)	Street (Built-Up Area)	Road (Open Area)	Street (Built-Up Area)
Light	< 1000	< 2000	< 150	< 250
Medium	1000 - 5000	2000 - 8000	150 - 700	250 - 1000
Heavy	> 5000	> 8000	> 700	> 1000

+ May be used in warehouse areas for track in pavement.

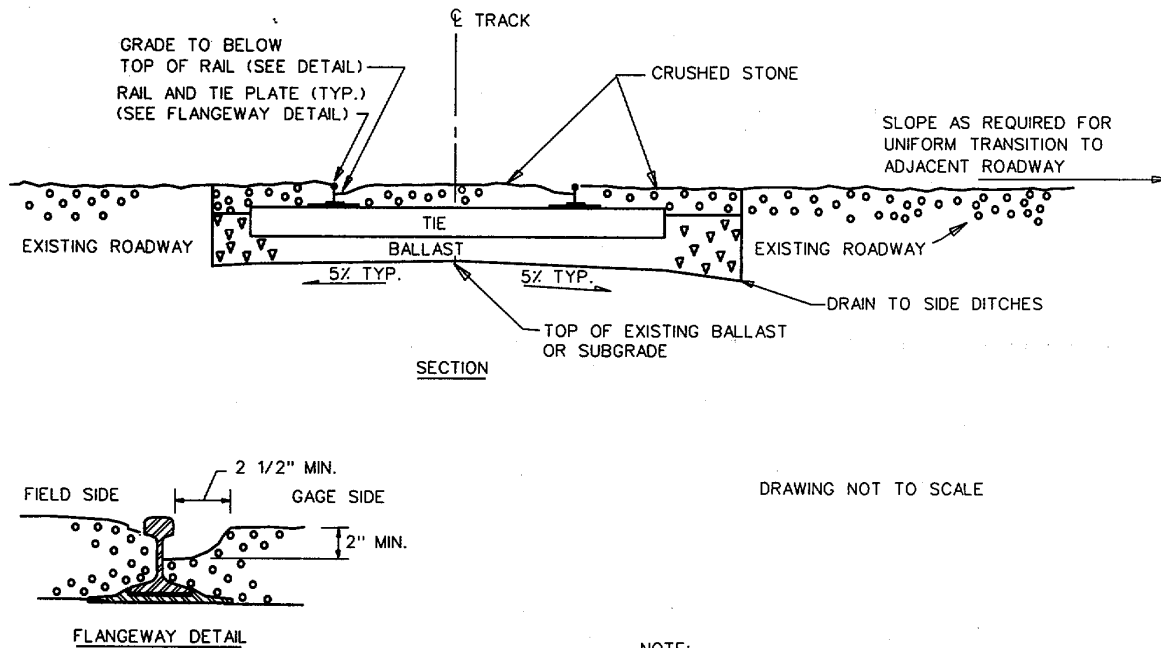

NOTE:
TYPICALLY THIS TYPE OF CROSSING WILL NOT REQUIRE
SUBGRADE RECONSTRUCTION.

Figure 6-25. Typical Type 1A Gravel Crossing.

(5) Type 4B crossings should be constructed of reinforced concrete having a minimum 28-day compressive strength of 5,000 psi.

c. *Drainage.* All crossings, for all surface types require a subdrainage system similar to that shown in figures 6-32 and 6-33. Geotextile surrounding the pipe and filter is optional, but recommended in fine-particle soils where clogging of the filter may occur.

d. *Track Construction.*

(1) When crossings are built or rebuilt, all the ties in the crossing itself and for at least 20 ft beyond each end of the crossing should be replaced. It is recommended that wood ties use in road crossings be 7" x 9" in cross section. When prefabricated road crossings are installed, tie length and spacing should conform with the installation requirements provided by the crossing manufacturer.

(2) For road crossings having heavy volumes of rail traffic and heavy vehicle traffic, it may be desirable to install tie pads beneath the tie plates in the crossing area, as shown in figure 6-34.

(3) In crossings on main running tracks, rail of 115 lbs per yd or greater is preferred.

(4) As bolted rail joints in road crossings are often a maintenance problem, it is recommended that all joints through the crossing and for 20 ft from either end of the crossing be welded. As an

alternative, 80-foot rails are readily available and may be used to eliminate joints in the crossing area.

(5) If the track approaching the crossing is anchored, it is recommended that each tie in the crossing be box anchored and that the normal anchoring pattern be maintained throughout the remainder of the crossing area (20 feet off each end).

(6) Once the crossing surface is in place, the track will be covered, making maintenance difficult and costly, thus the track geometry (gage, surface and alignment) should be nearly perfect before placing the crossing surface. The ballast in and around all the ties should be well compacted to prevent settlement and movement of the crossing.

(7) Crossing flange ways should have a minimum width of 2.5 in. with a maximum width of 3 in. and be at least 2 in. deep.

e. *Crossing Protection: Signs and Signals.*

(1) *Specifications and Minimum Requirements.* Specifications for the basic design and rail appearance of crossing warning signs, pavement markings, and warning signals are given in Part 8 of the Manual of Uniform Traffic Control Devices (USDOT-FHWA). All road crossings will have, at minimum, the standard warning signs shown in the MUTCD. The need for additional signs, flashing lights, or gates, depends on

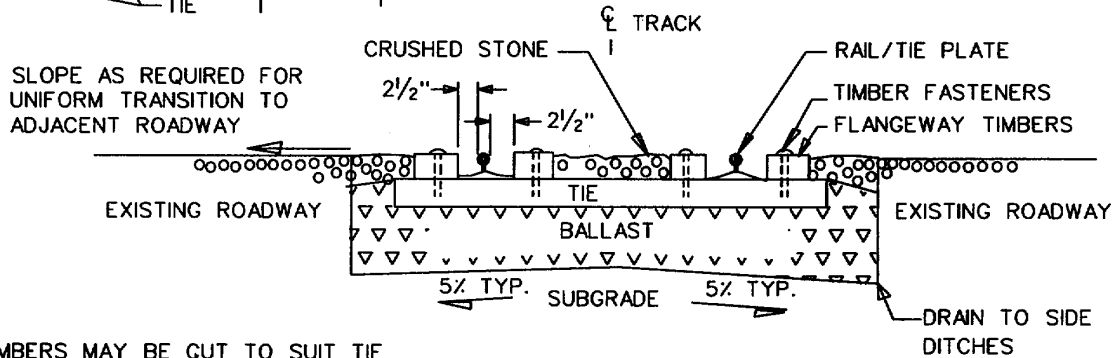
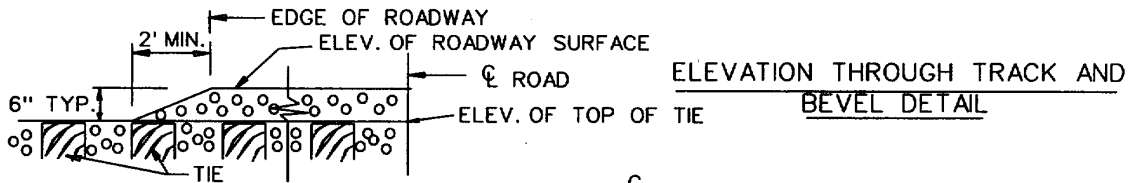
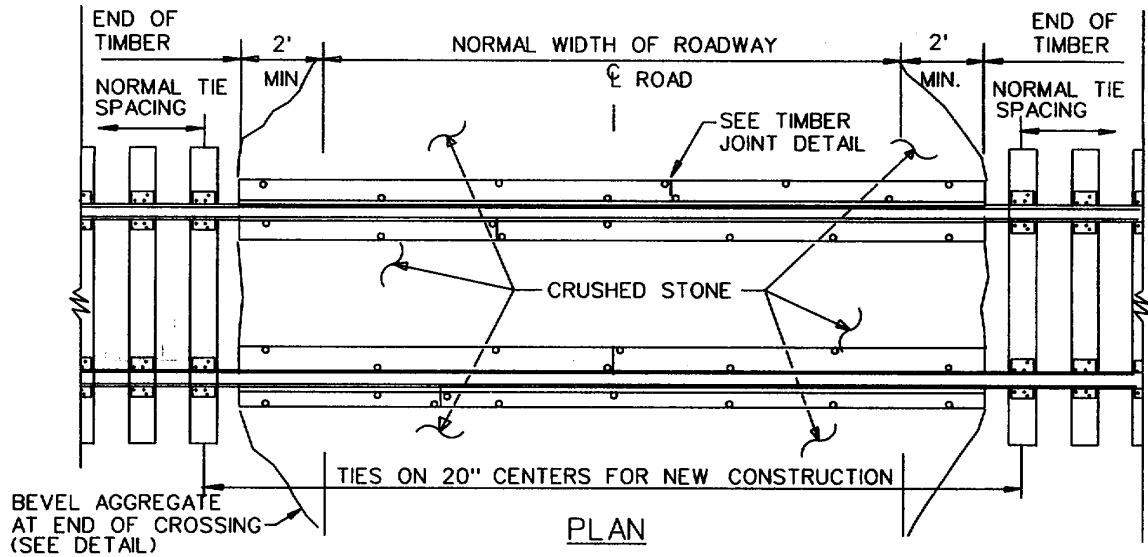

TIMBERS MAY BE CUT TO SUIT TIE SPACING (MAX. 4" EACH TIMBER) AT INTERMEDIATE JOINTS. STAGGER INTERMEDIATE JOINTS SO THAT TWO JOINTS DO NOT FALL ON THE SAME TIE.

DRAWING NOT TO SCALE

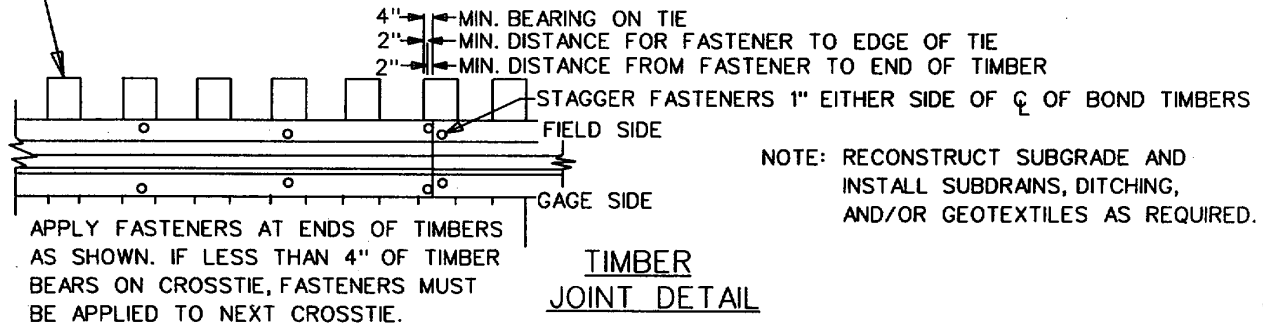
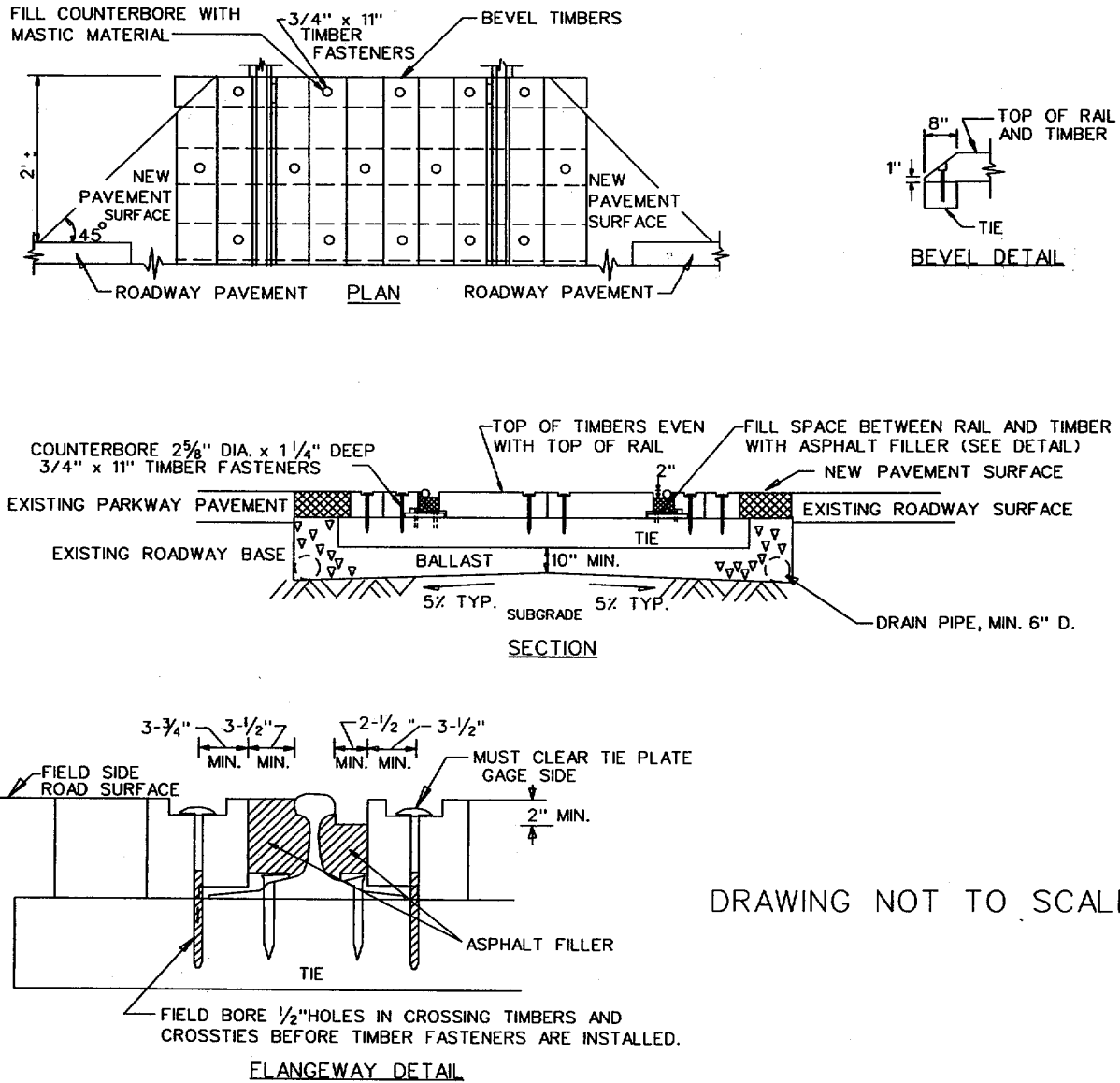

Figure 6-26. Typical Type 1B Gravel Crossing.



DRAWING NOT TO SCALE

Figure 6-27. Typical Type 2 Timber Crossing.

crossing visibility, traffic character and volume, crossing geometry, and accident and incident history, as described below.

(2) *Visibility.* Clear visibility criteria for approaching and stopped vehicles is shown in figures 6-35 and 6-36, with distances A and B determined from table 6-7. A crossing is considered visually unobstructed if the triangular area defined by distances A and B is sufficiently clear that a

motorist can see approaching trains anywhere within that field of view. Crossings which do not meet this clear visibility criteria may require additional protection.

(3) *Traffic Character and Volume.* Additional protection may be desirable at crossings which experience two or more train movements per day and the product of train movements and average daily vehicle traffic exceeds 3,000. This traffic threshold drops to 1,000 for crossings which are considered visually

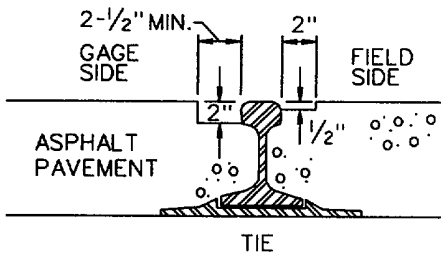
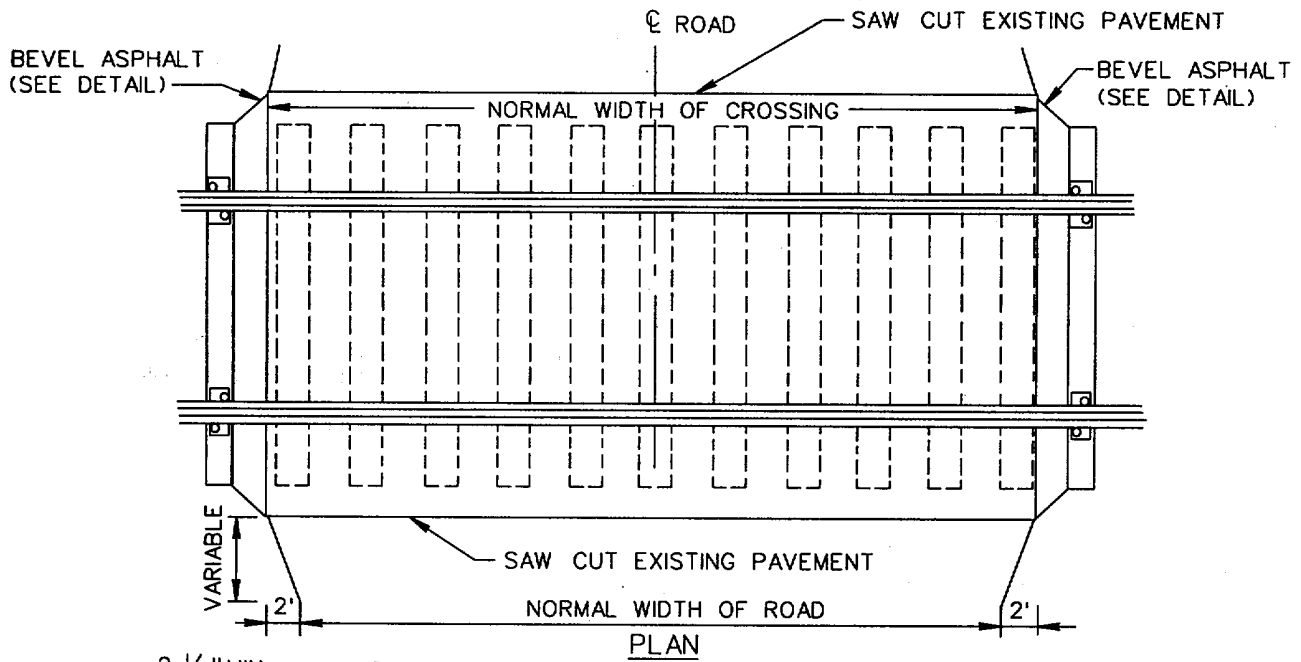

FLANGEWAY DETAIL

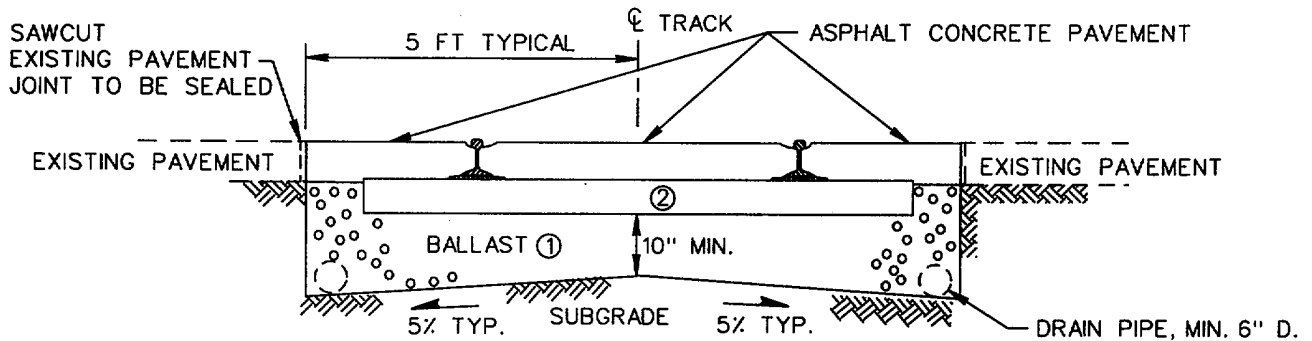
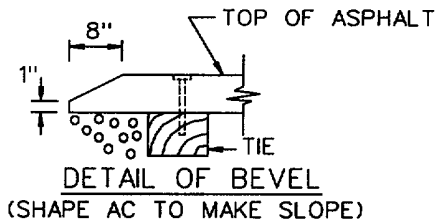

SECTION

DRAWING NOT TO SCALE

NOTE: RECONSTRUCT SUBGRADE AND INSTALL SUBDRAINS, DITCHING, AND/OR GEOTEXTILES AS REQUIRED.

Figure 6-28. Typical Type 3 Asphalt Crossing.

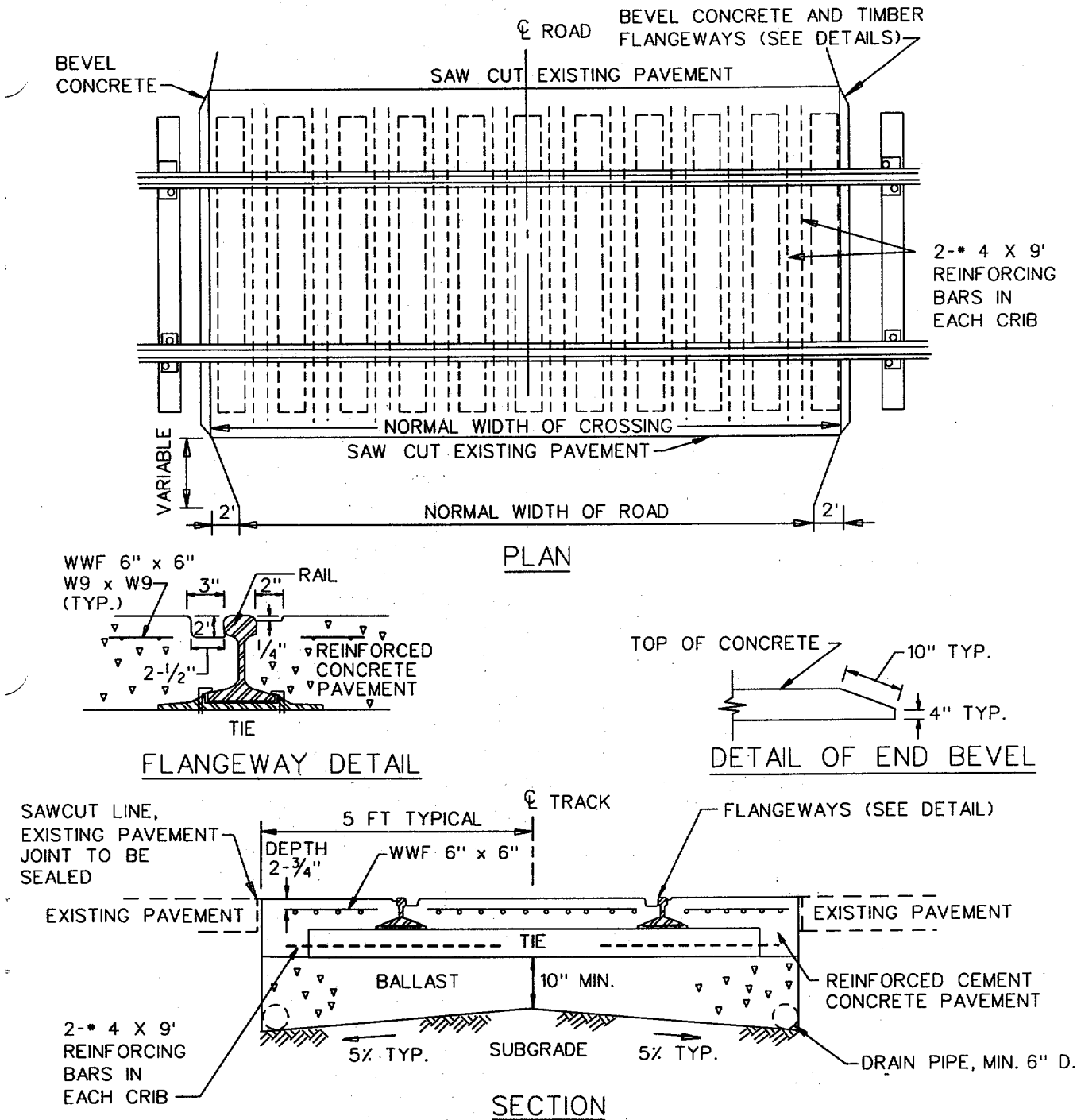

DRAWING NOT TO SCALE

Figure 6-29. Typical Type 4A Cast-in-Place Concrete Crossing.

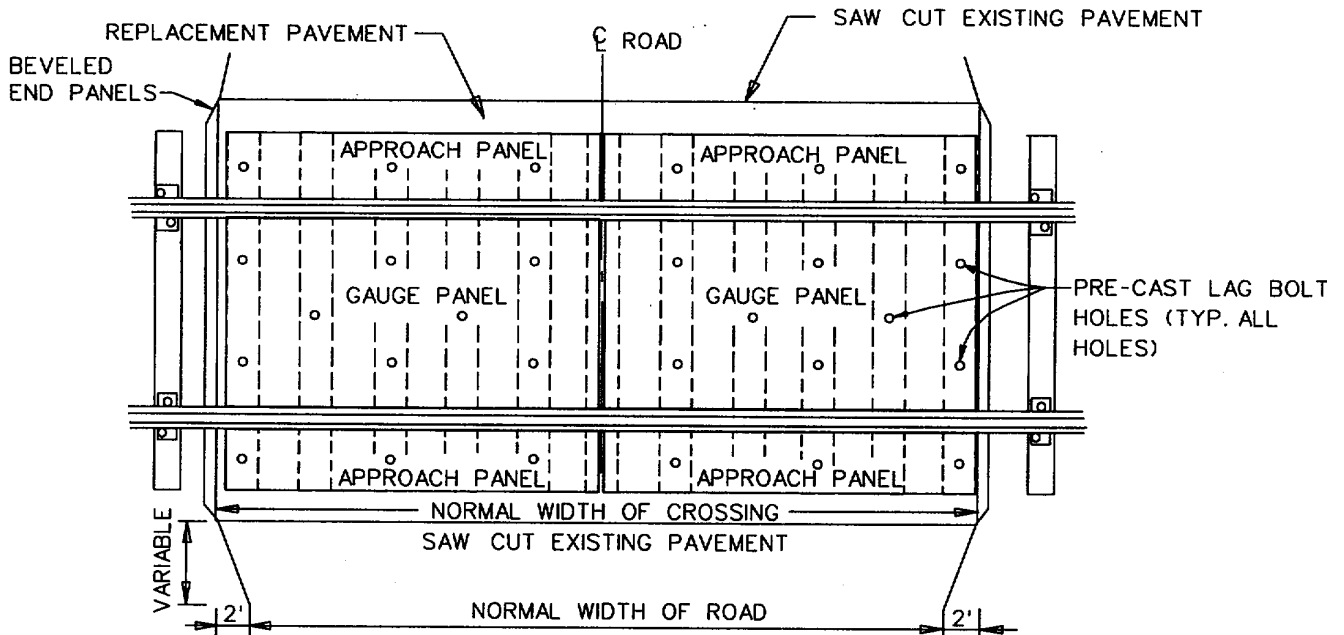

PLAN

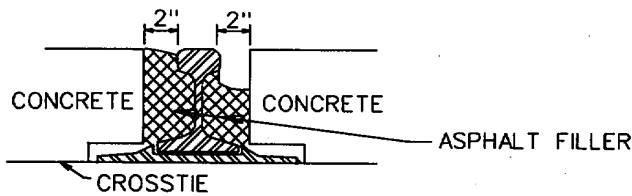

TYPICAL FLANGEWAY

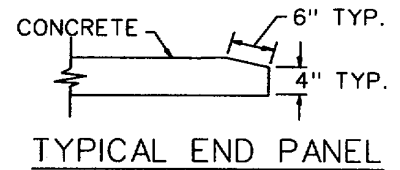

TYPICAL END PANEL

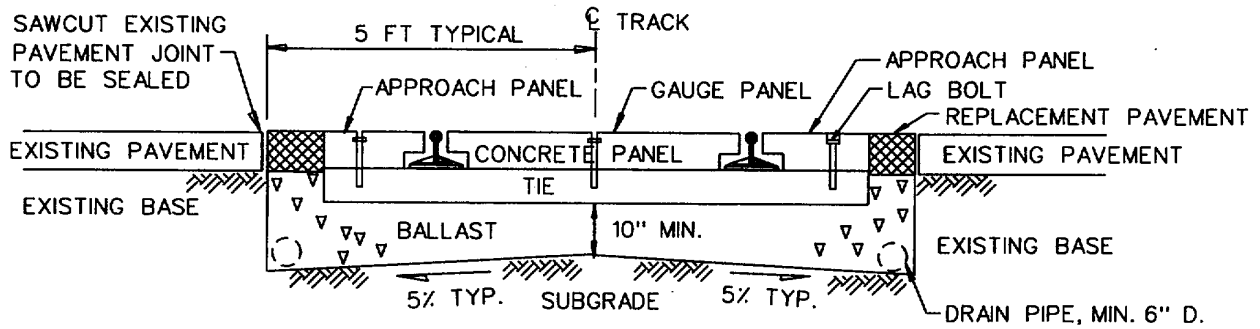

SECTION

DRAWING NOT TO SCALE

Figure 6-30. Typical Type 4B Prefabricated Concrete Crossing.

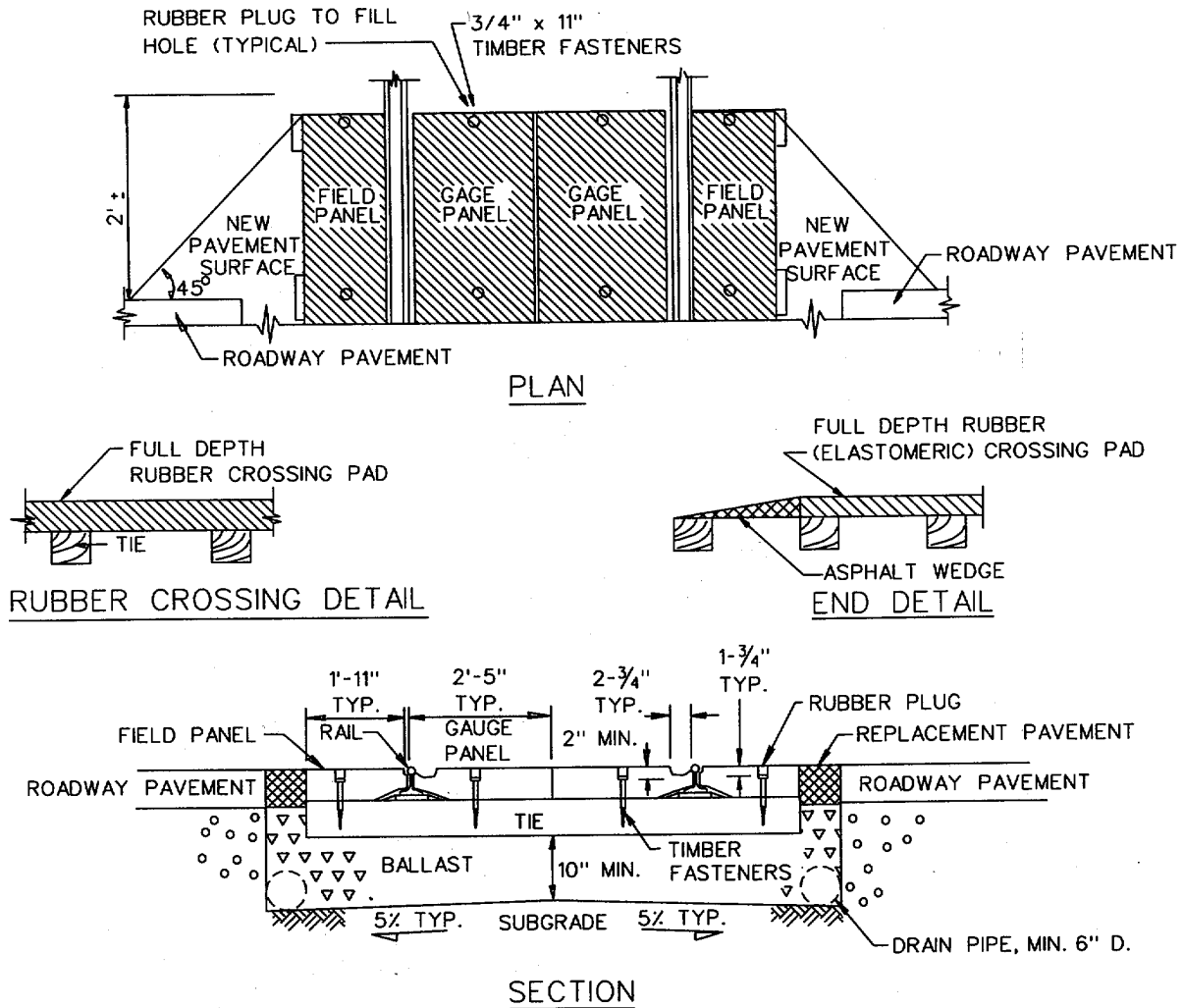

DRAWING NOT TO SCALE

Figure 6-31. Typical Type 5 Elastomeric (Rubber) Crossing.

obstructed, as defined above Flashing lights (or even gates) should be considered for crossings which experience several daily train movements and heavy truck traffic or frequent hazardous material traffic, especially if clear visibility criteria are not met.

(4) *Crossing Geometry.* Crossings with a road to track angle of less than 45 degrees, or where the road approaches the track at a steep grade may call for additional protection.

(5) *Accident and Incident History.* Crossings which have experienced at least one serious accident, some close-call incidents, and/or where incidents of motorists not obeying existing warnings are common, should at least receive consideration

for flashing lights, or gates if flashing lights are already present.

6-16. Rail Crossings.

a. *Recommended Types.* Bolted rail crossings, as described in AREA Plan 700A, are recommended for use on military track. Tie layouts and plates for various angle crossings are given in AREA Plans 700F through 700J.

b. *Anchoring Approaches.* Where rail anchors are used on the tracks approaching rail crossings, every third tie should be box anchored (four anchors per tie) for at least two rail lengths in all directions from the crossings.

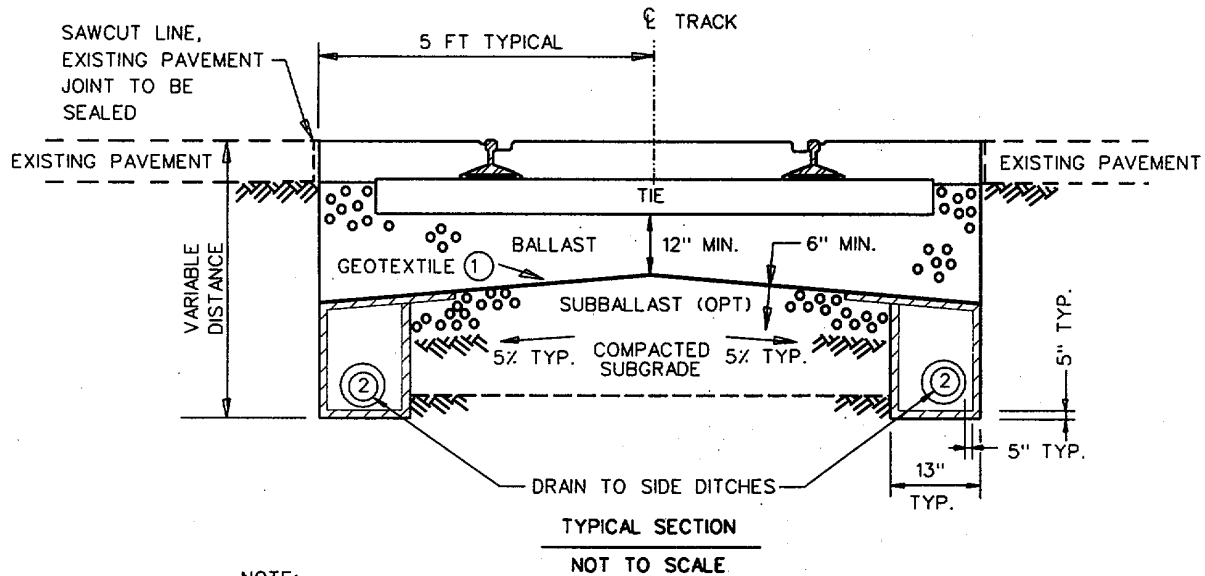

NOTE:

- ① GEOTEXTILE. MINIMUM 15 OZ/YD MEETING REQUIREMENTS OF CEGS 02274.
- ② SUBDRAIN OF CORRUGATED, PERFORATED, POLYETHYLENE OR GALVANIZED STEEL PIPE. MINIMUM DIAMETER 6 INCHES.

Figure 6-32. Typical Geotextile/Subdrain Installation for Vehicle Road Crossings.

c. *Application.* As rail crossings are expensive and require more maintenance than standard track, track layouts should be designed without the need for tracks to cross unless this is clearly necessary.

6-17. Bridges.

a. *Types.* Railroad bridges may be classified by deck type: open deck or ballast deck. In a typical open deck bridge, every fourth tie is bolted directly to the structure, thus in effect, the track becomes part of the bridge. In a ballast deck bridge, a standard track and ballast section are supported on a solid floor. The ballast deck has the advantage of allowing the track across the bridge to be lined and surfaced in the same fashion as standard track.

b. *Design Procedures.* When a bridge is required, the bridge structure will be designed by a practicing railroad bridge engineer in accordance with the AREA manual for timber structures, concrete structures, or steel structures. The AREA manual provides background and commentary on railroad bridge design practices.

c. *Basis for Design.* The design of railroad bridges is based on two main factors: the magnitude of applied loads to the bridge and the expected level of traffic (or number of stress cycles) over the design life of the bridge. One stress (or load) cycle is defined by one ap-

plication and release of loading on a bridge member.

d. Cooper E Series Loading.

(1) The design live load is expressed using the Cooper E series loading configuration adopted by the AREA about 1905. Figure 6-36 illustrates a unit E1 axle loading. Higher loadings are obtained by multiplying each load by the same constant; wheel spacings do not change. Thus, an E60 loading would show the largest axle loads as 60,000 lbs.

(2) To allow an easy comparison of permissible in-service loading (or rating) over the life of a bridge with the loads used in their original design, and to compare the effect of different engine and car loads for either design or rating, the railroad industry kept the basic Cooper load configuration and used it to represent all bridge loadings and bridge capacity ratings.

e. Equivalent Cooper Loading.

(1) In use, the loading from a train of typical (or heaviest common) cars (the design train) is converted to the Cooper E loading which would have the same effect on the bridge.

(2) For a given design train, the equivalent Cooper loading (E value) will vary with train operating speed, bridge span length, and bridge design.

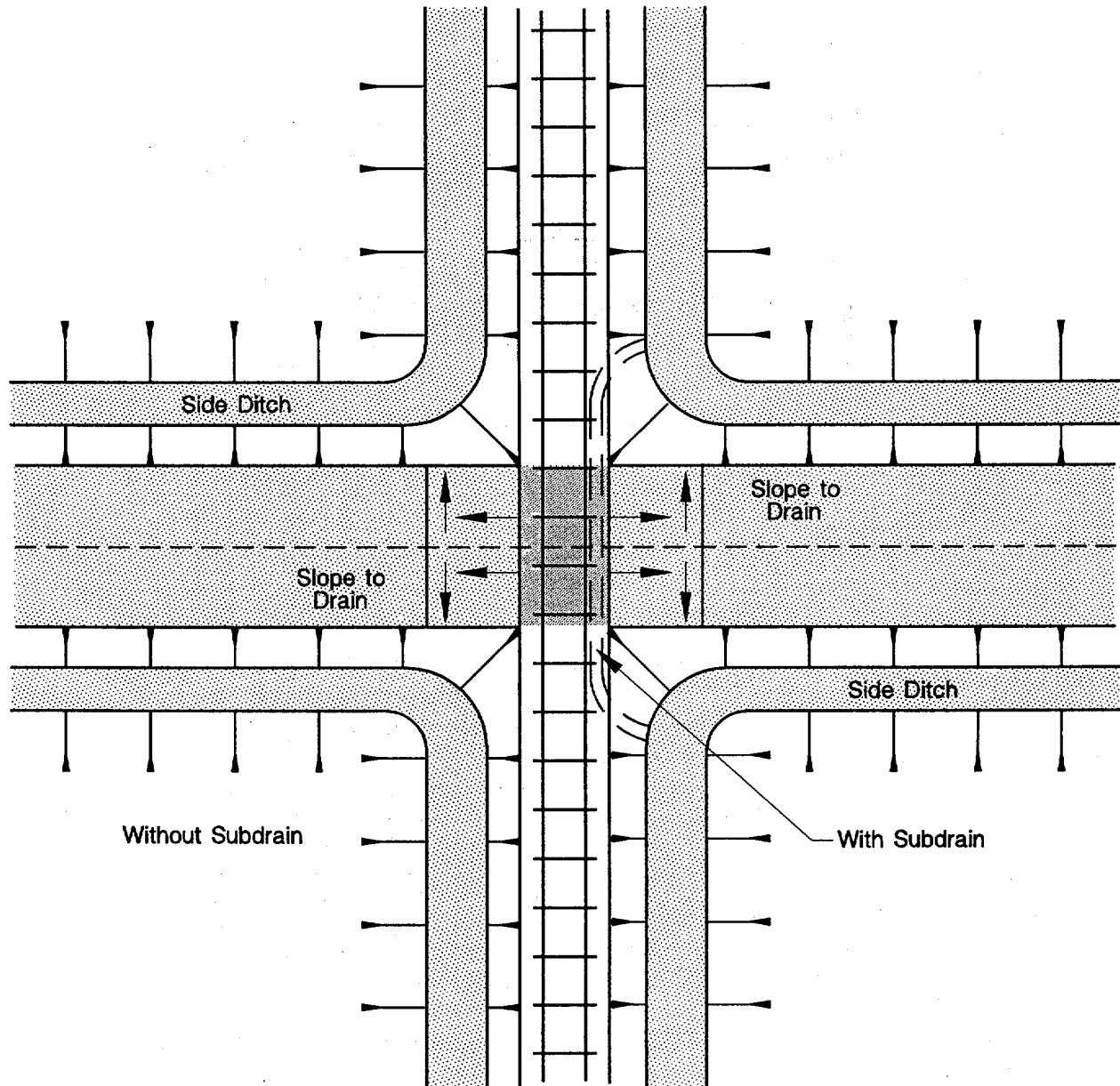

Figure 6-33. Typical Drainage at R Crossings.

(3) As the actual load distribution from current trains will differ from the Cooper configuration, the equivalent Cooper loading will not be a constant for all bridge components. Figure 6-38 shows the relationship between equivalent Cooper loading (at 60 mph) and span length for one type of steel bridge and for the loading shown in figure 6-39. As an example, figure 6-38 indicates that for a 60-foot span, the train in figure 6-39 produces an effect equivalent to a Cooper E48 load with respect to floor beam reaction, an E57 load with respect to end shear, and an E60 load with respect to bending moment.

f. *AREA Standard Fatigue Stress Cycles.* For fatigue, the standard AREA design assumes stress cycles from 100 trains per day, with 150 cars each (loaded up to 315,000 lbs gross weight), traveling at speeds up to 60 mph, every day for 80 years.

g. *Design Live Loads.*

(1) As the standard AREA fatigue loading is exceptionally high for most military railroad lines, designers should use the design live loading in table 6-8, which is based on the recommendations in the AREA manual. This loading is a general recommendation for span lengths up to about 75 feet. Actual design live loading may be adjusted to accommodate span length,

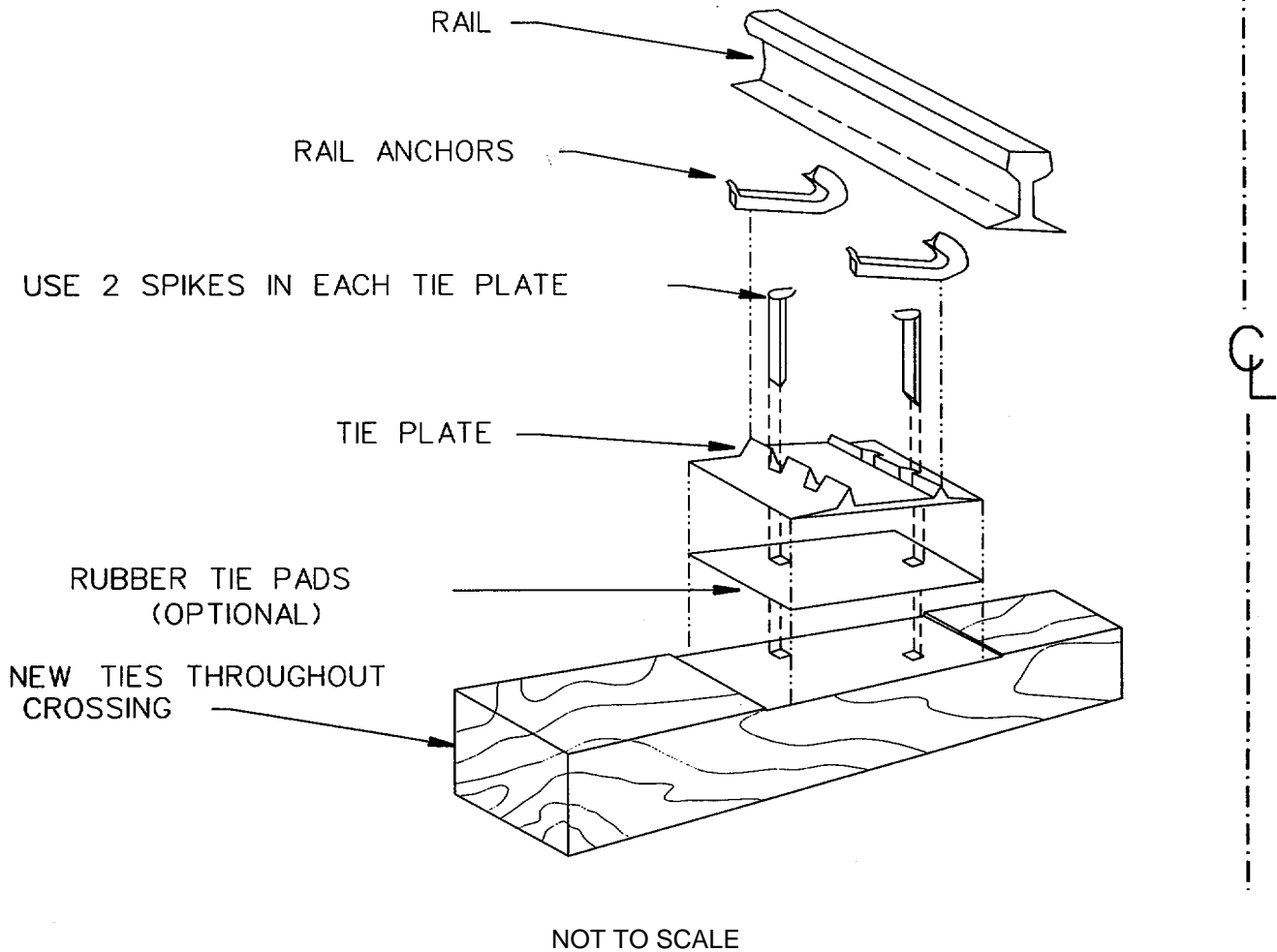

Figure 6-34. Recommended Track Construction for Road Crossings.

structure design characteristics, and other variables.

(2) Traffic over most military railroad bridges does not exceed 5 MGT per year, thus the 0-5 MGT category of table 6-8 usually applies. To exceed this lower level, a bridge would have to experience an average annual passage of 38,000 loaded 100-ton cars (104 per day) or 26,500 loaded 140-ton cars (73 per day) throughout the life of the bridge.

h. Walkways. When bridges are located in areas where switching movements are made and at

other locations where it is either useful or necessary for people to walk alongside a train (or cut of cars), walkways must be provided on at least one side of a bridge. Where people must have access to both sides of the track when a bridge is occupied, walkways must be provided on both sides. (Workers must never be expected to cross the track by going under cars, crossing over couplers, or climbing over cars).

i. Tie Pads. On open deck bridges, installation of rubber tie pads between the tie and tie plate is recommended.

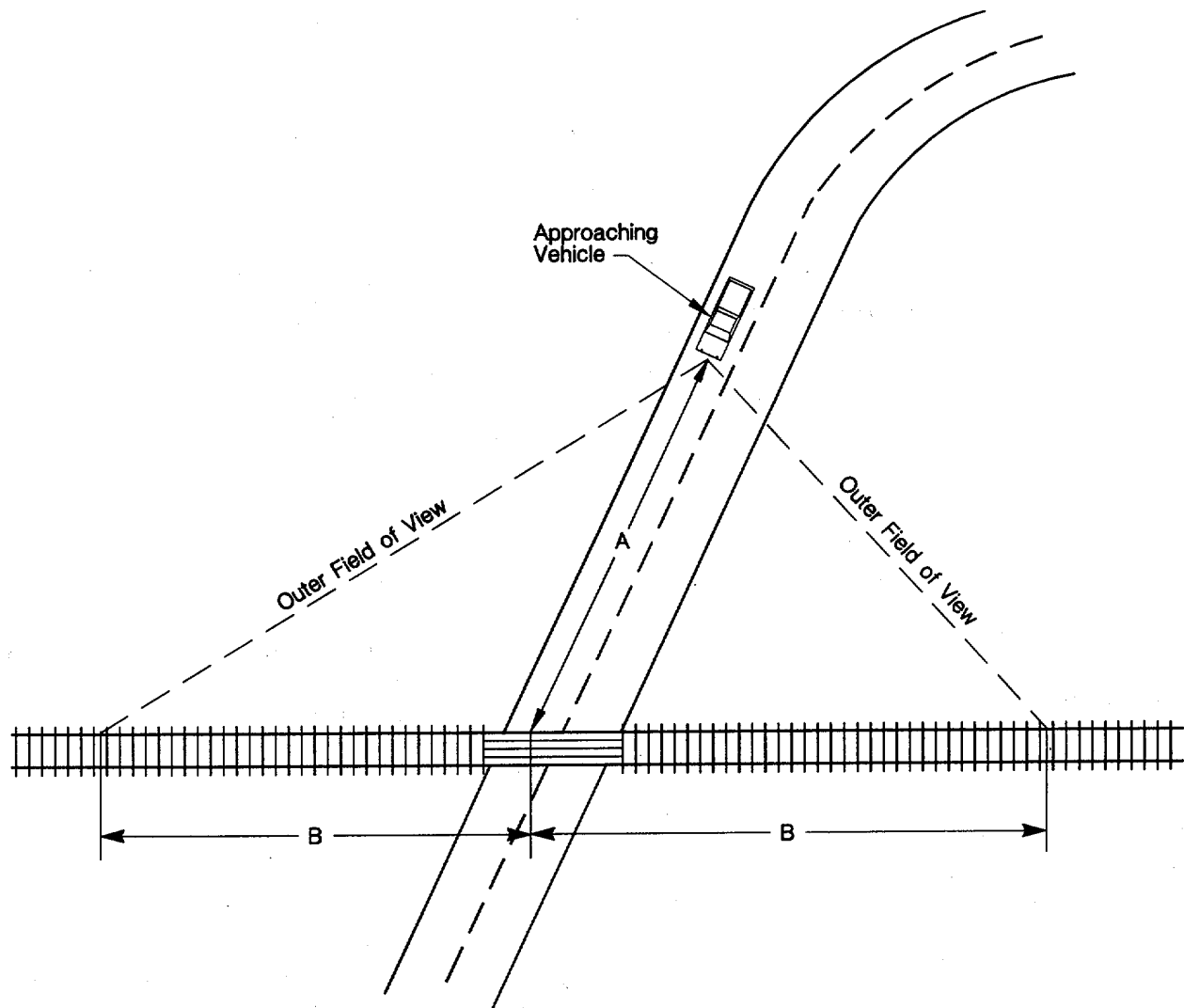

Figure 6-35. Clear Crossing Visibility Area for Approaching Vehicles.

6-18. Miscellaneous Track Appliances.

a. Derails.

(1) *Application and Type.* Derails are commonly used on spur tracks or sidings to prevent runaway cars or unauthorized entry onto the main track. Derails are also used to protect stand equipment stored on a track. Three different types are the switch point derail, permanent hinged sliding derail, and portable derail.

(2) *Location.* Derails should be located so that after running over the derail, a car would stop before reaching the point requiring protection. This distance depends mainly on track length and a gradient. Figure 6-40 illustrates derail placement.

(3) *Size and Designation.* Derails must be ordered for the size of rail on which they are to be

installed. The number of the derail usually indicates the distance (in inches) from the top of the rail to the top of the tie (including tie plate thickness). Derails generally come in even 1 in. sizes and can be shimmed up to 0.5 in. in height (or the ties on which the derail is attached can be added up to 0.5 in. deep) to accommodate height variations.

(4) *Direction.* Derails are designed as either left-hand or right-hand. The proper direction is determined by looking in the direction that the rolling stock to be derailed would be moving. A right hand derail is installed on the right hand rail and derails the cars off the right side of the track, while a left-hand derail is installed on the left-hand rail and always derails to the left.

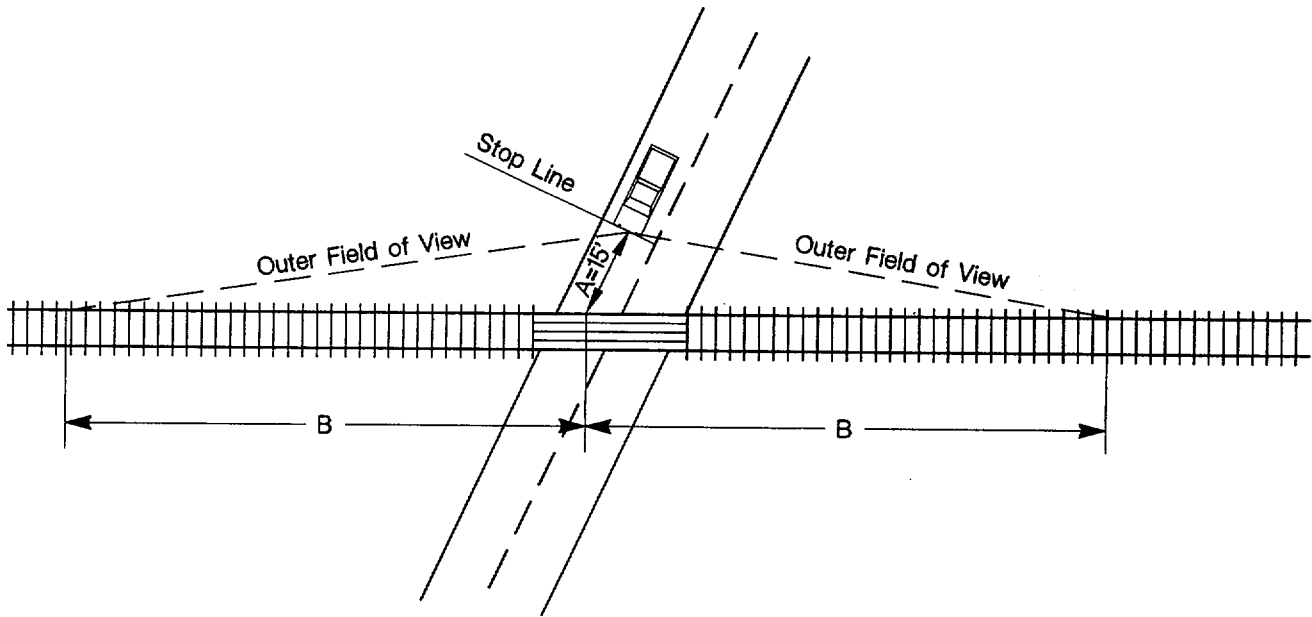

Figure 6-36. Clear Crossing Visibility Area for Stopped Vehicles.

b. Bonded and Grounded Track.

(1) Wherever cars carrying fuel, ammunition, or other flammable or explosive materials are unloaded, or where track is located adjacent to electrical equipment, the rails (and related track materials capable of conducting electrical current) must be bonded, grounded and insulated from the remaining track. This bonding and grounding helps prevent the discharge of static electricity during the loading or unloading of these hazardous materials. General requirements for bonding and grounding are given below; additional details are found in the AREA manual.

(2) When a side track, or section of running track, is to be bonded and grounded, an insulated joint should be provided on each rail at the first rail joint beyond the turnout of the adjacent main track at either end of the main track. The rails at all other joints in the track beyond or between the insulated joints will be bonded together with bond wires and both rails of the bonded track will be connected by grounding connectors to a single driven ground rod.

(3) An exothermic type rail bond ("cadweld bond") is recommended for the application of rail bonds on military track. Bond cables should be flexible bare copper stranded 1/0 AWG cables with preformed ends and should conform to the applicable requirements.

(4) Grounding rods should be 0.75-in. diameter copper clad steel rods or 1-in. diameter zinc coded steel rods. The minimum length of ground rods should be 8 ft. Ground rods should be driven vertically for their full length and the top of the

ground rod should be located a minimum of 12 in. below the top of the subgrade at the toe of the ballast slope. The maximum allowable resistance grounded rail or structures is 25 ohms.

(5) All electrical connecting hardware should bronze pressure type materials and have no rotating parts coming in direct contact with the conductors.

(6) Rail cross bonds are required to bond the two rails together. Rail cross bonds should be stalled using exothermic type bonds and 1/0 AWG flexible bare copper stranded cable. The cross bond should be applied to the rail head or rail web and the cable for the cross bonds installed minimum of 12 in. below the bottom of the ties.

One cross bonded ground rod should be installed . 100 ft intervals along tracks designated for the loading and unloading of fuel, ammunition and her volatile or hazardous materials.

(7) Defective bonds will be removed by shear cutting old cables immediately adjacent to the weld or pin. Flames or torches will not be used to !move defective or out-of-service bonds.

(8) Where overhead power lines in excess of 00 volts cross over the track, the rails will be lade electrically continuous and grounded for a stance of 150 feet on each side of the power lines.

c. track Scales.

(1) When required, track scales will be designed and installed in accordance with the AAR Scale Handbook, which appears as an appendix in Le AREA manual.

Table 6-7. Clear Visibility Distance at Road Crossings.

Clear Track Visibility Distance B for Vehicle at 15-foot Stop Line							
Train Speed Limit (mph)	10	15	20	25	30	35	40
Visibility Distance: B (feet)	200	300	400	500	600	700	800

Note: See Figure 6-36.

Clear Crossing Sight Distance A for Approaching Vehicle										
Vehicle Speed (mph)	10	15	20	25	30	35	40	45	50	55
Clear Sight Distance A(feet)	70	100	135	175	225	275	350	420	500	600

Clear Track Visibility Distance B for Approaching Vehicle										
Train Speed) (mph)	Vehicle Speed (mph)									
	10	15	20	25	30	35	40	45	50	55
10	60	70	80	90	100	110	120	130	140	150
15	90	105	120	135	150	165	180	195	210	225
20	120	140	160	180	200	220	240	260	280	300
25	150	175	200	225	250	275	300	325	350	375
30	180	210	240	270	300	330	360	390	420	450
35	210	245	280	315	350	385	420	455	490	525
40	240	280	320	360	400	440	480	520	560	600

Note: See Figure 6-35.

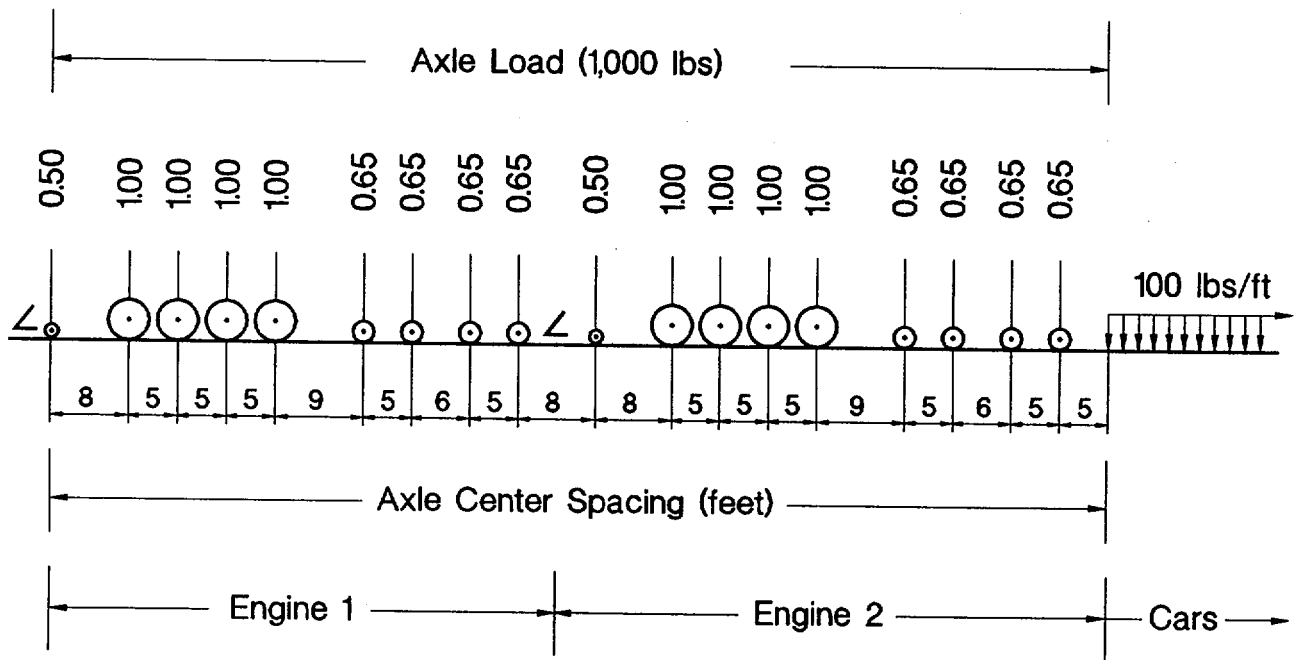

Figure 6-37. Cooper Load Configuration for Bridges.

(2) The design and construction of track scales is best performed by a commercial firm that specializes in design, fabrication and construction of railroad track scales.

d. Bumping Posts and Wheel Stops.

(1) Bumping posts, wheel stops or timber and earth mounds should be used at the open end of all stub tracks to prevent cars from rolling off the end of the track.

(2) Where it is not critical that railroad cars be absolutely stopped at track ends to protect personnel, facilities, or parked vehicles and equipment, and where no other hazards are present, consideration should be given to using low earth mounds or some type of wheel stop at the end of the tracks rather than coupler-height, solid bumping posts or obstructions.

e. Roadway Fencing. The character of the land use of property adjacent to the railroad and security requirements will govern the need for fencing along the right-of-way lines. The installation Physical Security Officer should be consulted to ensure that security fencing requirements are covered in the design.

f. Snow Fences. The AREA manual provides guidance on the application and construction of snow fences and other measures to minimize snow drifting on the track.

g. Cattle Guards. In areas where livestock or other large animals could enter the railroad right-of-way at road crossings, cattle guards may be necessary.

Two Six-Axle Locomotives Followed by 100-Ton Boxcars

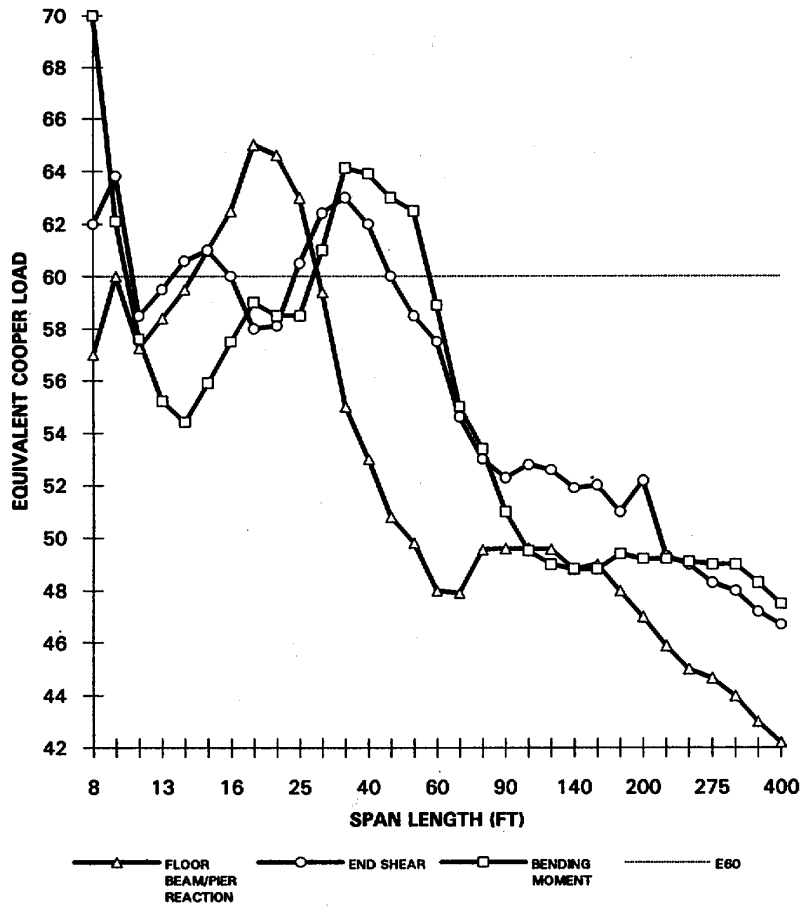

Figure 6-38. Variation in Cooper E Value with Span Length.

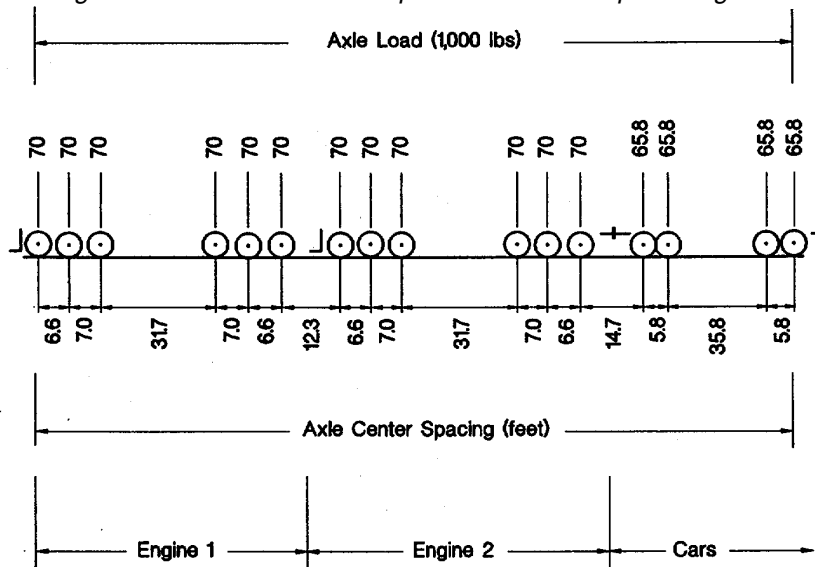
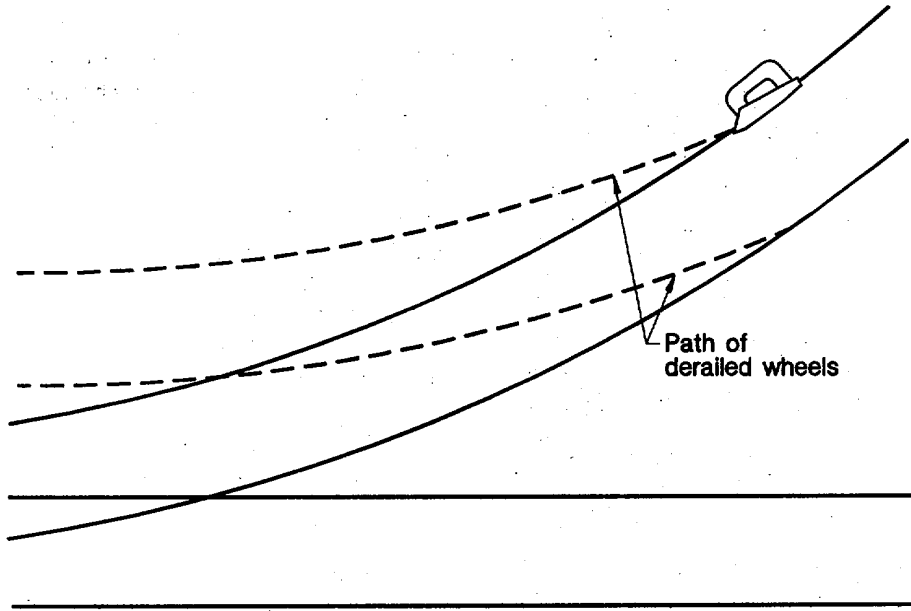

Figure 6-39. Loading Diagram for train of 100-Ton Boxcars.

Table 6-8. Recommended Cooper Design Load for Bridges.

Annual Traffic Volume (Million Gross Tons)	Recommended Cooper Design Load For Car Capacity Up To:		
	100 Tons	120 Tons	140 Tons
0 to 5	E 40	E 50	E60
5 to 15	E 60	E 65	E72

Note: 1 million gross tons approximately equals 7,600 loaded 100-ton cars or 5,300 loaded 140-ton cars.



a. Location of Derail on a Curve.

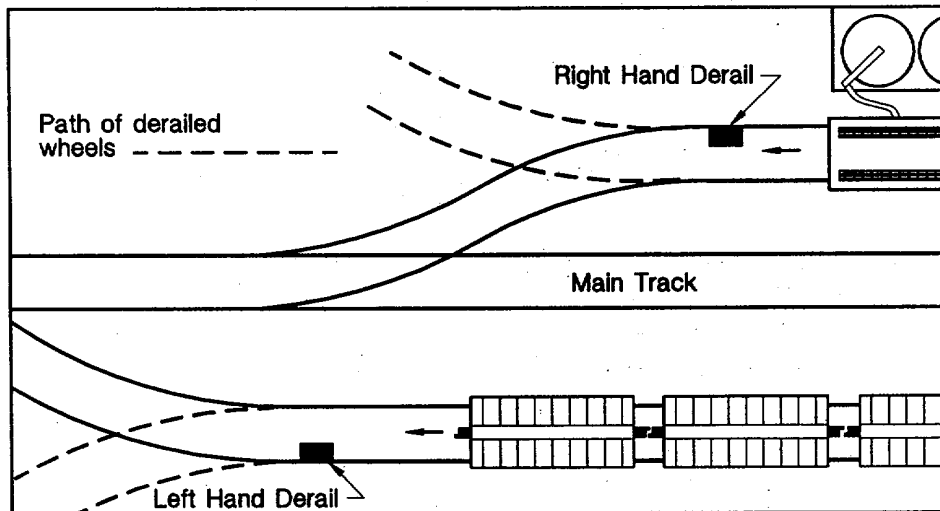

b. Derails Protecting a Main Track.

Figure 6-40. Location of Derails.

CHAPTER 7

GEOMETRIC DESIGN

7-1. Roadway Cross Section.

a. Right-of-Way Width. The right-of-way (or roadway) must be wide enough to accommodate the track, side ditches, portions of embankment or cut slopes, parallel service roads, and other structures and facilities necessary for the operation of the railroad. Figures 6-5 through 6-11 indicate the width required for the basic track structure.

b. Snow Allowance. In areas with heavy snowfall, additional roadway width (or ditch width) may be useful to provide sufficient room for snow plowed from the track.

7-2. Grades and Track Profile.

a. Grades. Gradient criteria for main running tracks are given in paragraph 3-3. Gradient criteria for terminal areas are given in paragraph 8-3.

b. Vertical Curves. Vertical curves are required as a transition between different grades. Transition rates are different for summits and sags. Here, summit refers to a convex curve where an ascending grade changes to a flatter grade, where a descending grade changes to a steeper grade, or where an ascending grade changes to a descending grade. Sags are concave curves which occur where an ascending grade changes to steeper grade, a descending grade changes to flatter grade, or where a descending grade changes to an ascending grade. (Note: It is best to avoid locating turnouts in vertical curves.) Table 7-1 shows recommended transition rates between grades. The length of track required for these transitions is determined from equation 7-1.

Table 7-1. Recommended Transition Rates Between Grades on Main Running Tracks.

Summits	Sags	
0.1	0.05	Minimum rate needed: Use where speeds will exceed 15 MPH and right-of-way length is ample.
0.2	0.1	Average rate: Use where speeds will not exceed 15 MPH or where transition length is limited.
0.3	0.15	Maximum rate where speeds will exceed 15 MPH.
0.4	0.2	Maximum rate where speeds will not exceed 15 MPH.

Note: Figures are given as percent change in grade per 100 feet of track length.

$$L = \frac{G_1 - G_2}{r} \times 100 \quad (\text{eq 71})$$

L = Length of track required for vertical curve (ft). G₁ and G₂ = slope of the two adjacent grades (percent), where ascending grades have a positive value and descending grades have a negative value. r = Rate of change in grade in 100 feet. (For main running tracks, use table 7-1. For terminal tracks, also (see para 8-3).

c. Track Profile. On either main running tracks or terminal tracks, a rolling profile (frequent changes in gradient) in the roadbed or in the final track surface (top of rail elevation) is undesirable. The criteria in table 3-2 should be followed to maintain an acceptably smooth track profile.

7-3. Horizontal Curves.

a. Definition. Railroads are laid out with circular curves using the chord definition. Curvature is measured in degrees, as indicated in equation 7-2.

D = Degree of curve (decimal degrees).

R = Radius of curve (feet).

b. Design Criteria.

(1) Design categories for curves on main running tracks are shown in table 3-3; for terminals, also use section 8-3.

(2) During the design of major track rehabilitation projects, it is recommended that, where practical, existing curvature above 10 degrees for main running tracks and 12 degrees in terminal areas be reduced below these limits.

c. Minimum Tangent Length Between Reverse Curves. When curves of different directions immediately follow each other (reverse curves) there must be a length of tangent track between the two curves to avoid train operating difficulties. The minimum tangent lengths between reverse curves are:

Degree of Curve	Minimum Tangent Length
06	60ft
6-12	100 ft

d. Superelevation.

(1) For either new design or major rehabilitation, the outer rail in curves should be elevated above the inner rail by the amount shown in table 7-2. Designs should not call for a combination of speed and curvature which fall below the bottom stepped ledger line in the table.

Table 7-2. Design Superelevation for Curved Track.

Degree of Curvature	Maximum Operating Speed, mph						
	10	15	20	25	30	35	40
0.50 1.00							
1.50 2.00	NO SUPERELEVATION REQUIRED						1.0
2.50 3.00					1.0	1.0	1.5
3.50 4.00				1.0	1.0	2.0	2.5
4.50 5.00			1.0	1.0	1.5	2.5	3.0
5.50 6.00			1.0	1.5	2.0		
6.50 7.00			1.0	1.5	2.0		
7.50 8.00			1.0	2.0			
8.50 9.00 9.50 10.00 10.50 11.00 11.50 12.00			1.5				

DO NOT DESIGN FOR OPERATION IN THIS RANGE

Note: Table entries are superelevation in inches.

(2) Full superelevation must be provided around the entire curve. For curves with 1-inch superelevation, that elevation may be run out (transitioned back to level) in 40 feet of tangent at the beginning and end of the curve. Where superelevation is more than 1 inch, spirals will be provided at each end of the curve.

e. Spirals.

(1) When, used, spiral transition curves will be designed as shown in the AREA manual. Superelevation will uniformly increase from zero at the beginning of the spiral (at the tangent) to the full elevation at the end of the spiral (where full curvature is reached).

(2) Spiral length will be determined from equation 7-3.

$$L_s = 40 \times S \quad (\text{eq 7-3})$$

L_s = Length of spiral (feet).

S = Full superelevation (inches).

f. Increase in Gage on Very Sharp Curves. Where curves of 12 degrees or more cannot be avoided, finished track gage will be as follows:

Curvature Range (degrees)	Track Gage (Inches)
12 to 14	56 5/8
14 to 16	56 3/4

7-4. Turnouts.

a. Introduction. Structural design of turnouts and design options are covered in paragraph 6-14, which should be used in combination with this section for complete turnout selection and specification.

b. Size.

(1) Turnout size is designated by the size of the frog used in the turnout, as illustrated in figure 7-1. The size of the frog determines the

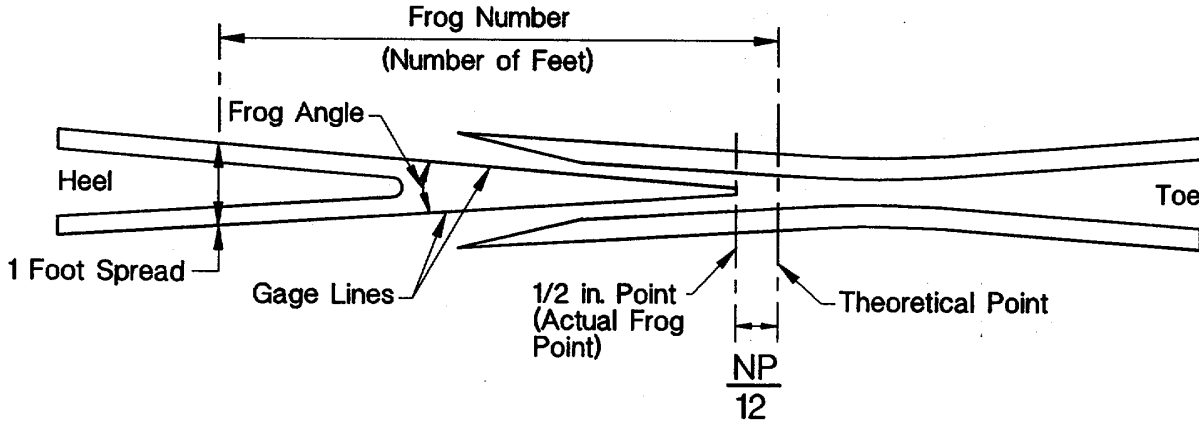

Figure 7-1. Determining Frog Number (Turnout Size).

angle at which the turnout track diverges from the tangent track. Frog size also influences the required degree of curvature within the turnout.

(2) Turnout size should be selected according to table 7-3.

Table 7-3. Turnout Size Selection Criteria.

Turnout Size	Turnout Curvature (degrees)	Selection Criteria
10	7.4	Preferred where space permits, or where long cars (over 75 feet) or 140-ton flatcars (with 3-axle trucks) are being handled Use for crossovers.
9	9.3	Smallest size recommended for handling long cars (over 75 feet) or 140-ton flatcars (with 3-axle trucks). In ladder tracks, saves space compared to a number 10.
8	11.8	Not recommended for handling long cars (over 75 feet) or 140-ton flatcars (with 3-axle trucks). Smallest size normally permitted.

c. Layout Data and Dimensions.

(1) In most cases, designers will use the dimensions and layout data for standard turnouts shown in AREA Plans 910 and 911. Turnouts may be laid out as left-hand, right-hand, or equilateral, as shown in figure 6-23.

(2) On occasions, when non-standard layout is required, or where different point lengths are used, turnout layout may be determined from figure 7-2 and equations 7-4 through 7-7.

$$\frac{h - t}{\sin s} = \quad \text{(eq 7-4)}$$

S = Switch angle (degrees).
 h = heel spread (inches). (Standard dimension is 6.25 inches).
 t = thickness of switch point (inches). (Standard dimension is 0.25 inches).

a = length of switch point (inches).

C = Long chord (feet).

q = g - e - h (feet), where g is track gage, e is frog toe spread from AREA Plan 910, Column 21, and h is the switch heel spread distance (which has a standard value of 0.52 feet).

F = Frog angle (degrees), from AREA Plan 910, Column 17 (converted to degrees).

S = Switch angle (degrees).

$$r \sim \frac{C}{2 \sin 1/2 (F - S)} \quad \text{(eq 7-6)}$$

R = Radius of curved closure rail (feet).

C = Long chord (feet).

F = Frog Angle (degrees)

S = Switch Angle (degrees).

L = a + C + d (eq 7-7)

L = Lead ((feet).

a = Switch length (feet).

C = Long chord (feet).

d = Frog toe length, from AREA Plan 910, Column 19 (feet).

d. *Equilateral Turnouts.* In an equilateral turnout, the diverging angle (frog angle) is divided equally on both sides, thus the turnout has two curved stock rails and two curved closure rails which mirror each other. Likewise, the degree of curve along each closure rail is half that of a standard left or right-hand turnout.

e. *Turnouts on the Inside of a Curve.*

(1) When not required by space limitations or other local conditions, turnouts to the inside of a curve will be avoided.

(2) Curvature through a turnout on the inside of a curve equals the degree of curvature for the curve plus that for a standard turnout. Thus, a number 10 turnout off the inside of a 3 degree curve will have a curvature of 3 + 7.4 = 10.4 degrees. The total curvature must not exceed design limits.

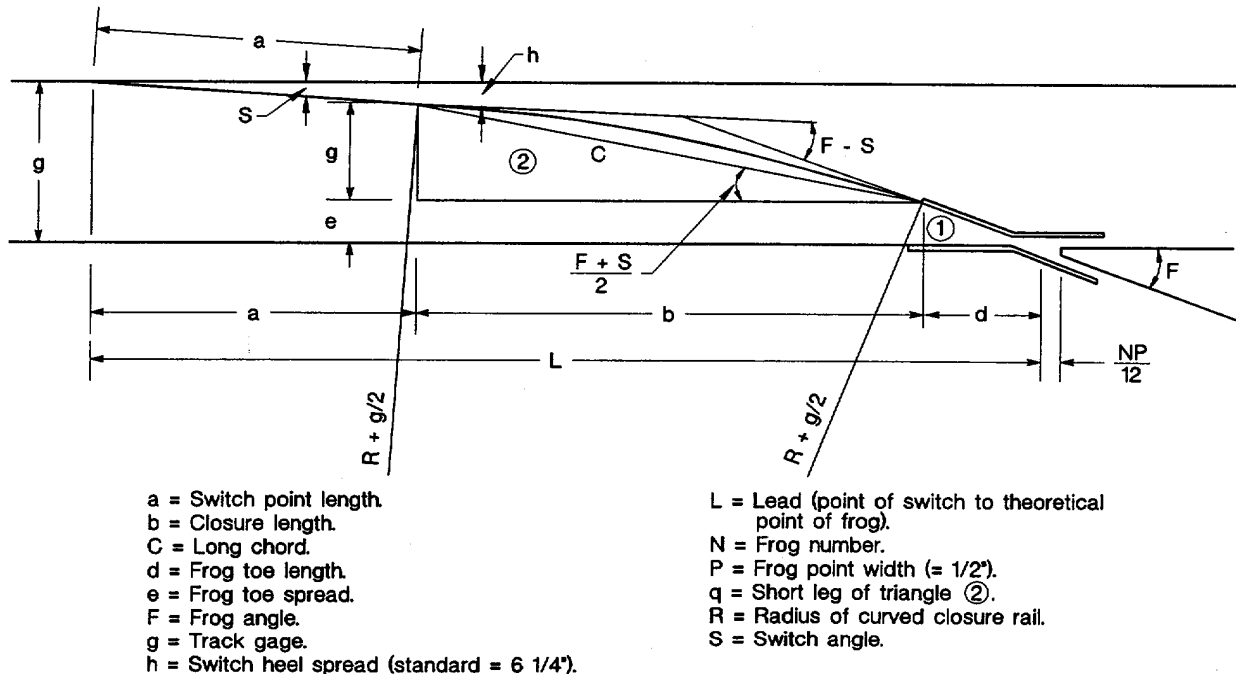

Figure 7-2. Turnout Design.

7-5. Track Connections and Ladder Tracks.

a. Diverging Routes.

(1) Figure 7-3 shows the layout for a typical diverging route connection. Note that the angle that the route diverges is the same as the frog angle for the turnout. The distance from the intersection of track center lines to the location of the frog point is given by equation 7-8.

$$BK = g(N) + 24 \quad (\text{eq 7-8})$$

BK = Distance from points B to K, as shown in figure 7-3 (feet).

g = Track gage (feet).

N = Frog number.

(2) For layout of parallel siding connections, as shown in figure 7-4, the tangent distance Q should be at least 50 feet.

b. Crossovers. Crossovers are a combination of two turnouts used to join two adjacent tracks, as shown in figure 6-23.

c. Ladder Tracks. Figure 7-5 illustrates a typical ladder track, shown between points A and H. This arrangement is commonly used for parallel yard tracks or loading tracks. (Also see chapter 8 for layout of yard and terminal tracks).

7-6. Clearances.

a. Clearances Will Be Checked. For either new construction or rehabilitation work, the location and position of all tracks will be checked for

proper clearances before the final design is prepared and after construction is complete. Allowances will be provided for future track surfacing (adding ballast and raising track) and for small k' changes in alignment during maintenance.

b. Recommended Minimum. Minimum clearances are shown in figure 7-6 and table 7-4. Vertical clearances are measured from the top of the rail, and horizontal clearances are measured from the center line of track.

c. State Requirements. Each state has legal requirements for railroad clearances. These are summarized in a table in chapter 28, section 3.6 of the AREA Manual. Where a state requires greater clearances than shown in figure 7-6 or table 7-4 the state requirement will be met.

d. Curved Track. For each degree of curvature, side clearances will be increased 1-1/2 in. over that required in figure 7-6 and table 7-4. When an obstruction is located adjacent to tangent track, but the track begins to curve within 80 ft of the obstruction, the side clearances shall be increased by the following amounts:

Distance from Obstruction to Curved Track, feet	Increase Per Degree of Curvature, inches
0-20	1-1/2
21-40	1-1/8
41-60	3/4
61-80	3/8

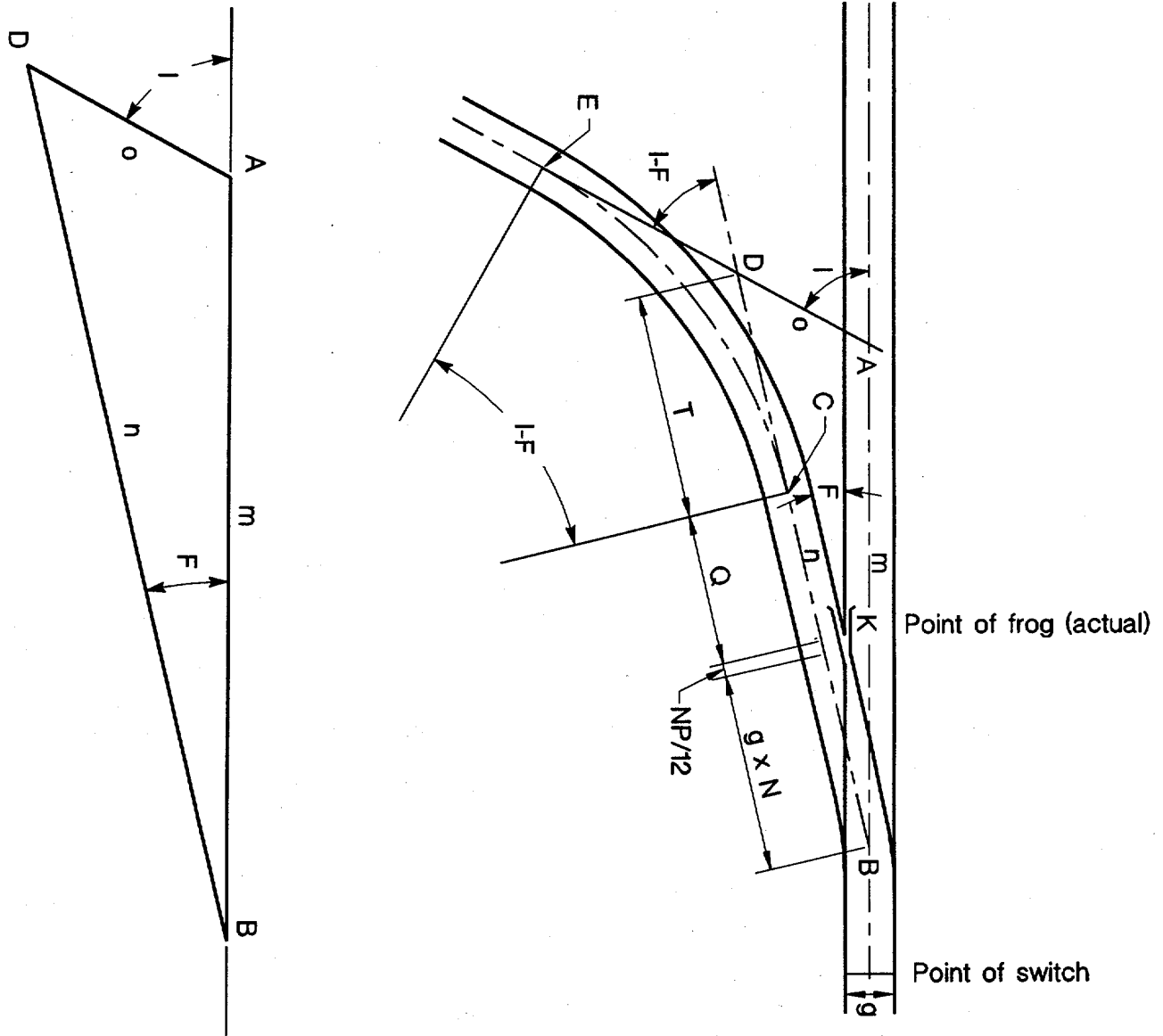

Figure 7-3. Diverging Route Connection.

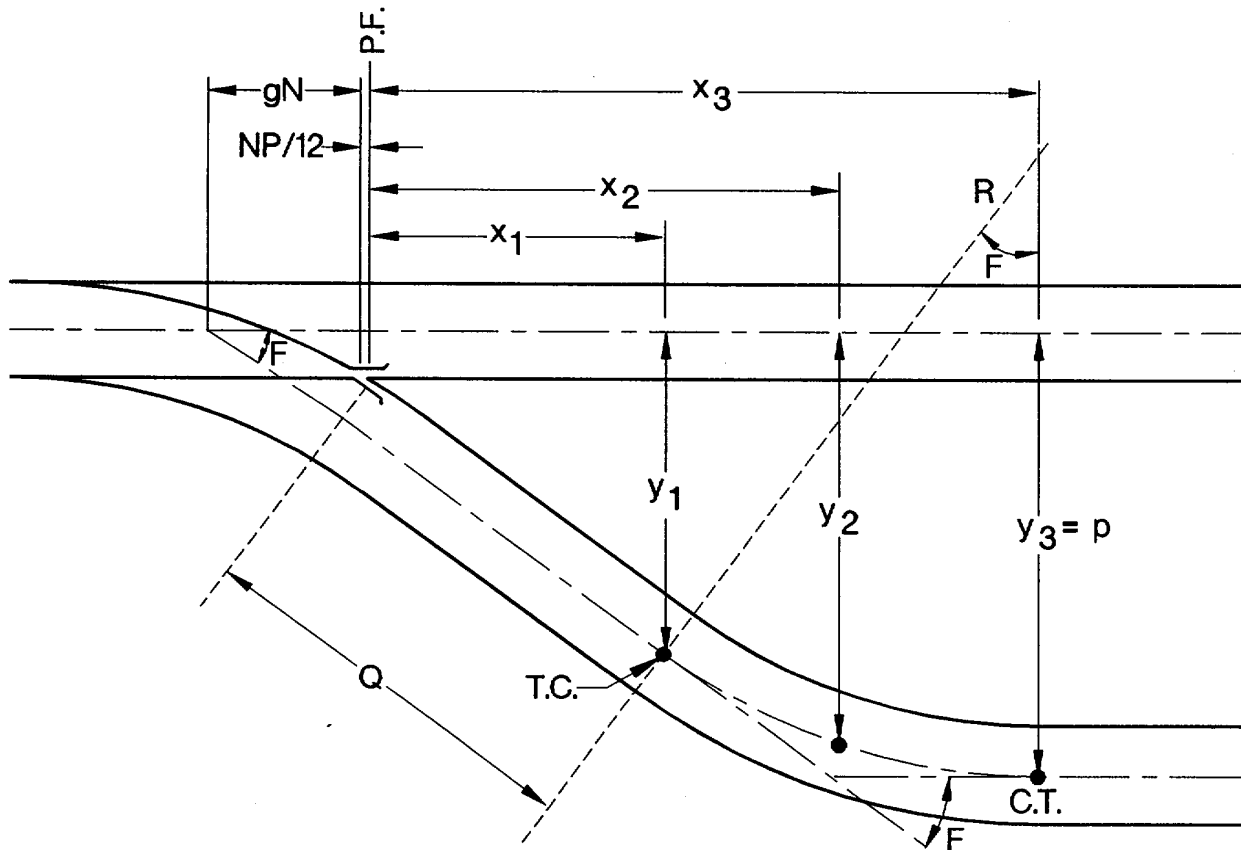

Figure 7-4. Parallel Siding Connection.

e. *Minimum Track Centers.* The recommended minimum distance between the center lines of adjacent tracks is as follows:

Between:	Minimum Distance Between Center Lines (feet)
Main tracks	15
Siding or yard track and main	15
Yard of storage tracks	14 (15, if space permits)

f. *Clearance Points At Turnouts, Ladder Tracks, and Crossings.*

(1) Figure 7-7 shows how to determine the location of clearance points at turnouts, ladder tracks, and rail crossings. As no car or piece of equipment may be left standing on a track with any part of it extending past the clearance point (toward the track junction), the clearance point will determine the usable length of sidings, loading, yard, and storage tracks.

(2) Clearance points will be marked by a 12-inch yellow bar painted on both sides of the rail base.

(3) If derails are used, they must be set to derail equipment before it reaches the clearance point.

7-7. Road Crossings.

a. Crossing Location and Site Requirements.

(1) The need for, and appropriate location of, a new crossing will be checked with the installation master plan. As road crossings increase maintenance costs and safety risk, their number should be held to a minimum.

(2) Once the requirement for a road crossing is established, a study should be performed to determine the available sight distances from vehicles approaching the track and from trains approaching the crossing from either direction. (see para 6-15e.)

(3) The ideal crossing geometry is a 90 degree intersection of the track and road with slight ascending grades on the road approaches to reduce the flow of surface water toward the crossing. Conflicting superelevations often result in long-term maintenance problems and poor performance of the crossing and should be avoided.

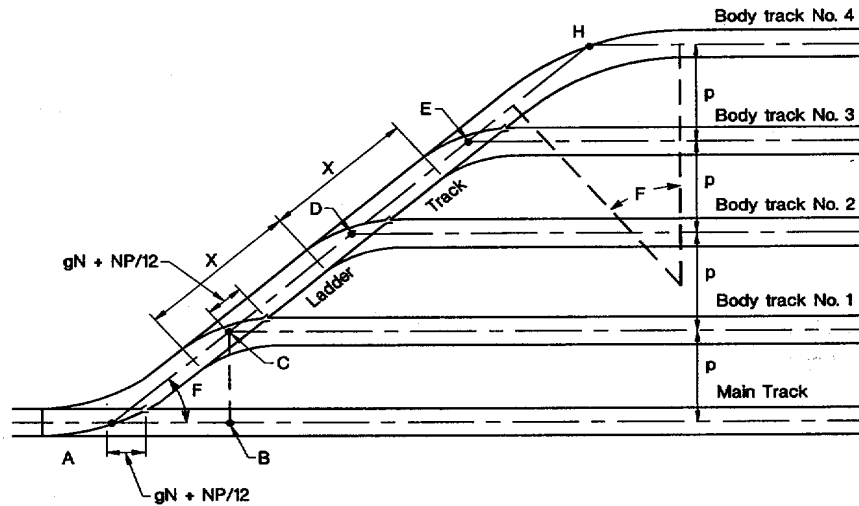

F = Frog angle.
 gN + NP/12 defines location of actual point of frog.
 p = distance between track centerlines.
 X = distance between points of switch.

Figure 7-5. Ladder Track Layout.

33' Overhead Wires (Exceeding 15,000 Volts)

30' Overhead Wires (750 to 15,000 Volts)

28' Overhead Wires (Incl. 750 Volts or less)

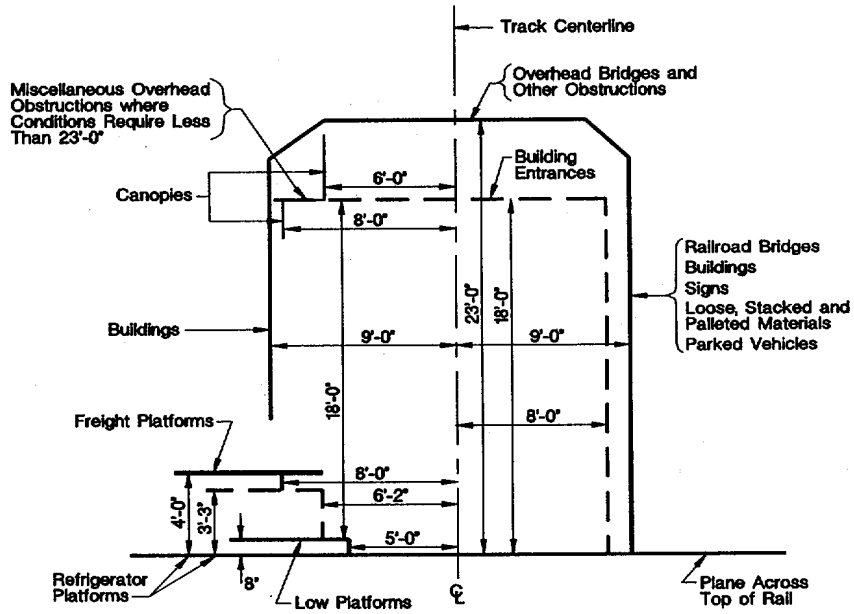

Note: Protect vertical clearances less than 23 feet and side clearances less than 9'-0" (other than track appurtenances) by an approved type of warning device.

Figure 7-6 Clearance Diagram for Tangent Track.

Table 7-4. Overhead and Side Clearances for Tangent Track.

Obstruction	Required Clearance
<u>Vertical Clearances (from top of rail)</u>	
Overhead wires: (open supply, arc wires, service drops) 0 to 750 volts 750 to 15000 volts Exceeding 15000 volts	28 feet 30 feet 33 feet
Other overhead wires	28 feet
Building entrances (including engine-houses)	18 feet
Overhead bridges	23 feet
Other overhead obstructions	23 feet
<u>Side Clearances (from track center)</u>	
Buildings	9 feet
Buildings without platforms (delivery required)	8 feet
Platforms:	
Freight platforms up to 4' maximum height	6 feet - 2 inches
Refrigerator car platforms up to 3' - 3"	6 feet - 2 inches
Refrigerator car platforms 3' - 3" to 4' high	8 feet
Low platforms (less than 8" high)	5 feet
Engine-house entrances	7 feet
Building entrances (other than engine-house)	8 feet
Canopies over platforms (canopy height <= 18')	8 feet
Fences, retaining walls, utility poles, and other obstructions	8 feet
Bridges	9 feet
Signs	9 feet
All loose, palleted, and stacked materials	9 feet
Parked vehicles	9 feet

Note: In curves side clearances will be increased 1-1/2 inches per degree of curvature.

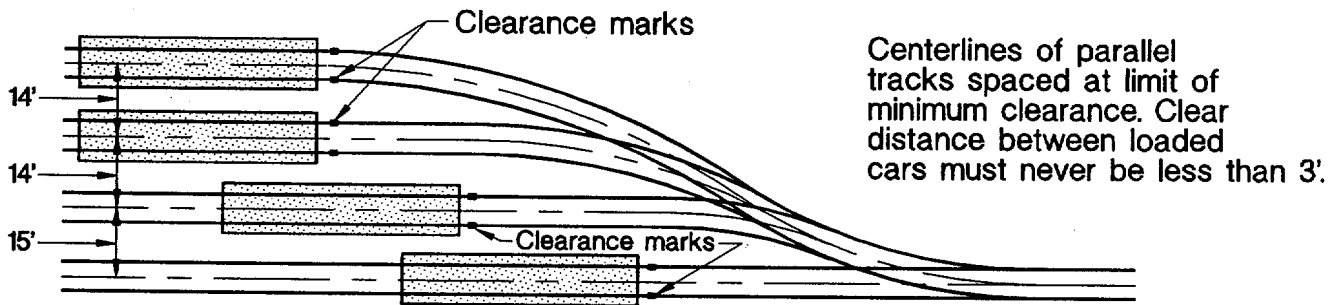
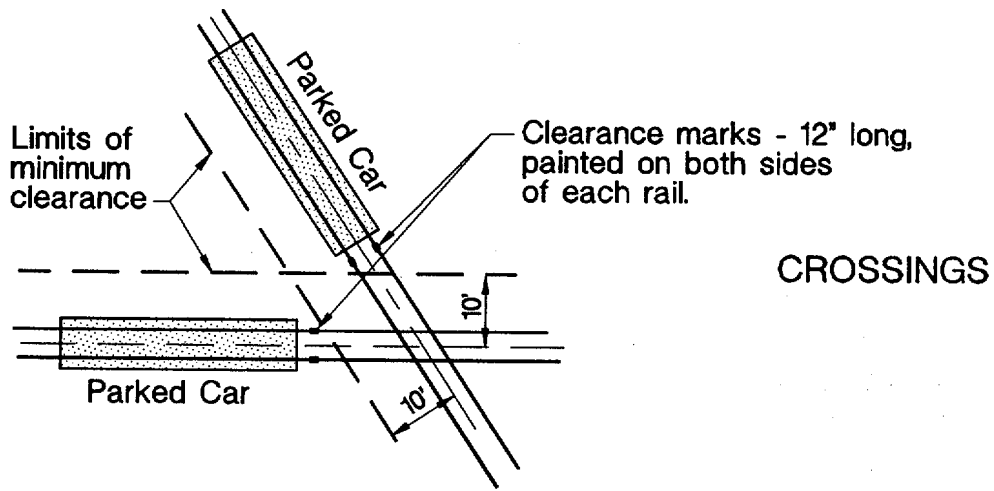

Note: Where M1 tanks are handled, increase track center spacing by an additional 1 foot.

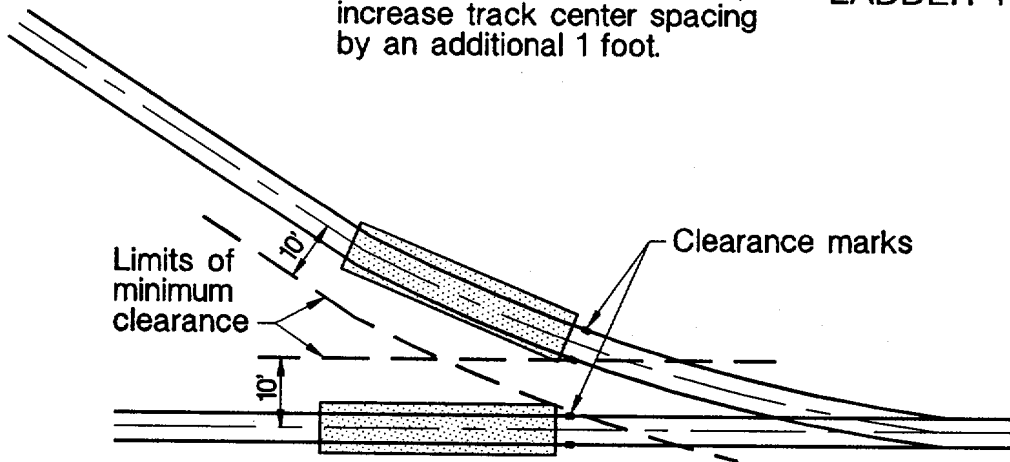

Figure 7-7 . Location of Clearance Points.

CHAPTER 8

TERMINALS

8-1. Introduction.

a. This chapter addresses the design of railroad terminal and support facilities which are primarily intended to support unit mobilizations. (Design and planning information for terminals at supply depots or ammunition plants should be obtained from the Construction Branch of the Army Materiel Command).

b. Terminals contain track and facilities for:

(1) Loading and unloading. Tracked and wheeled vehicles, containers, equipment, ammunition, fuel, and general supplies.

(2) Holding. Empty cars waiting to be loaded or loaded cars waiting to be unloaded, or cars which require repair or adjustment of the load or tie-downs.

(3) Switching. Maneuvering cars around the terminal, re-ordering or turning a line of cars, or allowing an engine to get on either side of a cut of cars.

(4) Interchange. Holding loaded or empty cars waiting to be picked up by the connecting commercial carrier, or cars delivered to the installation by the commercial carrier.

(5) Storage. For cars infrequently used or moved.

(6) Fueling and housing engines.

8-2. Siting and General Layout.

a. In the siting and layout of terminals, the designer must consider space requirements, logistics, security, safety, the presence and use of existing facilities, character of the terrain and natural drainage, as well as mission requirements. When locating a terminal area, a site must be selected which has the correct size, shape, and orientation so that it provides convenient access for both vehicles and railroad service.

b. Where space is very limited, two or more separate terminals may be considered to provide sufficient capacity. This option may result in better traffic flow and less congestion that might occur at a single site, but might also complicate command control of loading operations and security arrangements.

8-3. Track Design.

a. *Design Wheel Loads.*

(1) For through running tracks in term areas, use table 2-2, "10 MPH or Less."

(2) For tracks where cars are simply placed

and removed (as distinguished from those where general running or back and forth switching movements frequently occur), such as warehouse sidings and spur tracks (dead end tracks), including loading and storage tracks, use table 2-2, "Light led Use".

(3) For run-around tracks, passing sidings, yard tracks, wyes, balloon tracks, or other tracks where switching movements commonly occur, use table 2-2, "10 MPH or Less."

b. *Gradients.*

(1) Gradients on running tracks through a terminal should not exceed 1.0 percent.

(2) On auxiliary tracks where cars may be temporarily left standing during switching, gradients should generally not exceed 0.3 percent.

(3) Gradients on tracks where cars will be left standing for one or more days, such as loading, yard, and storage tracks, should generally not exceed 0.2 percent, with a maximum allowable of 0.3 percent. It is desirable to have these tracks slope away from the main track (or connecting track). Thus, if hand brakes do not properly hold on cars, they would not roll toward the main track.

(4) Yards are best graded as shown in figure 8-1, with tracks sloping toward the center, where storm drainage is provided. This grading arrangement will prevent cars from accidentally rolling toward either ladder track and will also facilitate drainage by collecting runoff at the center of the yard.

c. *Vertical Curves.*

(1) Maximum vertical curvature in a summit should normally be 0.4 percent change in grade in 100 feet, but may be as high as 0.8 percent change entering (or exiting) loading, storage, or other spur (dead end) tracks. Corresponding values for sags are 0.2 and 0.4, respectively. Where track space is available and no interference occurs, use the lower values. The higher values are sometimes needed to avoid putting vertical curvature through a turnout, road crossing, or alongside a loading dock.

(2) It is best to avoid locating turnouts in vertical curves as sometimes problems with point fit or operation result.

d. *Horizontal Curves.* Track curvature should not exceed 12 degrees in terminal areas. Where nal number 9 or 10 turnouts are the smallest recommended size, curvature elsewhere on the track :ed should not exceed 10 degrees.

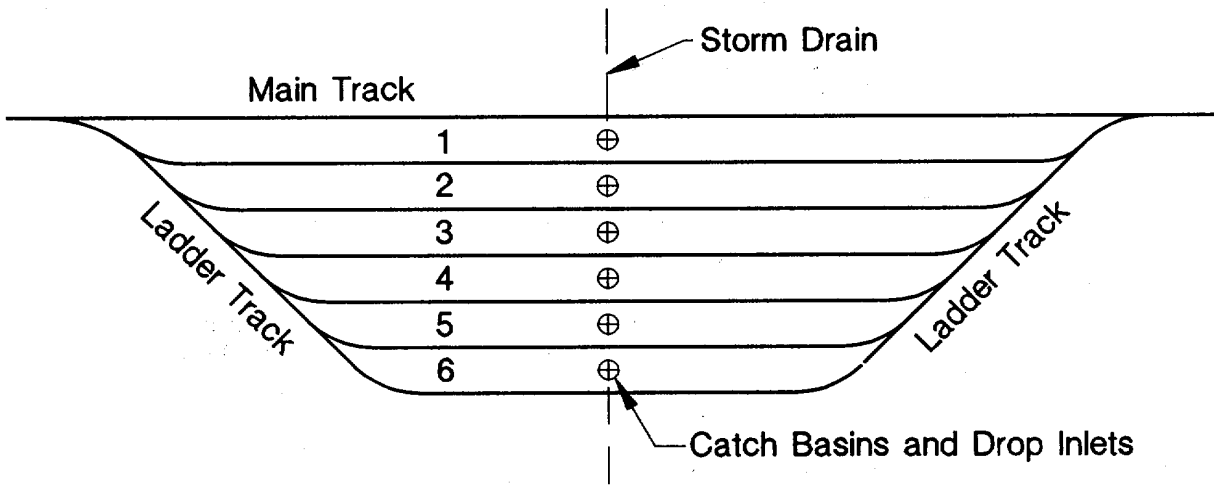

a. Plan View

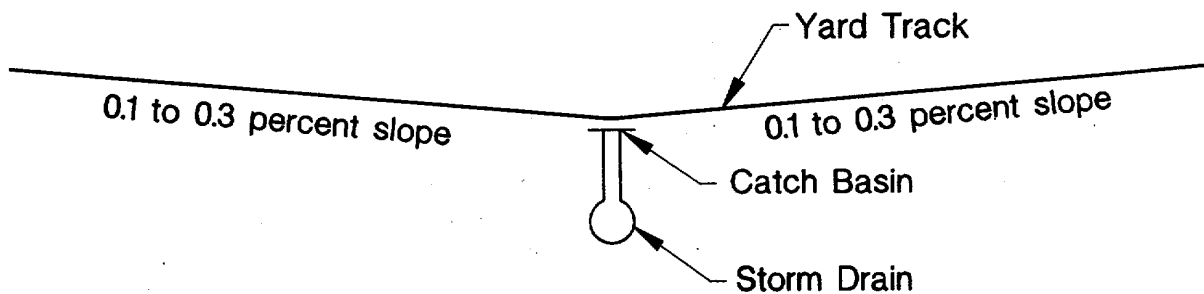

b. Elevation

Figure 8-1. Typical Small Yard with Storm Drainage.

e. *Track Layout.* Design guidance for the layout of turnouts, curves, ladder tracks, and track connections is covered in chapter 7.

8-4. Clearances and Usable Track Length.

a. As terminal track is typically closely spaced near loading docks, buildings, access roads, parking and staging areas, parallel tracks, etc., awareness of clearance requirements is especially important. Clearance requirements are covered in section 7-6.

b. The maximum usable track length for positioning cars extends from the end of track (for spur tracks) to the clearance point, or (for sidings) between two clearance points, as indicated in figure 7-7.

8-5. Vehicle Terminals.

a. *Purpose and Facility Requirements.* A vehicle loading terminal is generally designed for transferring tracked or wheeled vehicles on or off flatcars, or in the case of smaller wheeled vehicles, auto

racks (trilevel cars). A vehicle terminal will contain: loading tracks to position on the flatcars; a nearby staging area to hold the vehicles; end ramps or multilevel ramps for transferring the vehicles to and from the railroad cars; a crew and communications facility; and a storage building for blocking and bracing material.

b. Tack Spacing. When the loading tracks in a vehicle terminal are laid out parallel to each other (as is often the case), the tracks should be spaced far enough apart to accommodate one-way vehicle traffic, as shown in figure 8-2.

c. Track Length and Number of 'racks.

(1) For vehicle loading, strings of between 10 and 20 cars are most effectively handled at a time: the lower limit of 10 to minimize switching requirements and the upper limit of 20 for efficient loading. Thus, each loading track should have a tangent length extending from 10 to 20 car lengths from the loading ramp, as shown in figure 8-3.

(2) The number of tracks required can be determined from the traffic and mission information covered in chapter 2, the space available in the terminal area, and the criteria for track length above.

d. Staging Area

(1) The size and location of a staging area depend on terrain characteristics and availability of space. It is recommended that a staging area be located as close to the loading area as possible to facilitate better command and control. The staging area should be large enough to stage one full loading cycle of vehicular cargo, thus a loading terminal with a capacity of 50 flatcars would require a staging area with a capacity of 50 carloads of vehicles.

(2) The staging area must include an access road (or approach) leading up to the loading ramp, which is straight and in line with the ramp for at least the full length of the longest vehicle to be loaded. If practical, this in-line approach should be twice the length of the longest vehicle to ensure that a vehicle can always be positioned ready to load as the first vehicle is driven up the ramp. It is also preferable that this road not be directly adjacent to any tract to avoid a dust cloud from the approaching vehicles reducing the view of loading operations.

(3) For operation after dark, staging areas need to be lighted with "parking lot" type lighting. Fencing may also be required if the cargo is security sensitive. (see para 8-13).

e. End Ramps for Tracked and Larger Wheeled Vehicles.

(1) Rapid loading of larger vehicles onto flatcars is best accomplished with permanent end

ramps constructed at the end of the loading tracks. While end ramps may be constructed with concrete, wood, steel or earth, they must be capable of supporting the largest and heaviest vehicles being mobilized (typically, a main battle tank).

(2) A general reinforced concrete ramp design is shown in figure 8-4. More detailed guidance should be obtained from the Army Transportation Systems Center (CEMRD-ED-TT).

(3) A well designed end ramp will:

(a) Allow an M-1 Abrams tank to be driven onto a flatcar having the lowest platform height used in commercial railroad service. (Note: It is safer and easier to drive a vehicle from a lower ramp level to a higher flatcar level than vice-versa).

(b) Provide ample width to enable guides to walk on both sides of an M-1 tank.

(c) Provide sufficient level platform length to allow a tank to be in a completely horizontal position prior to proceeding onto the railcar.

(d) Have the proper transition between the incline and the level platform so that a tank will not "high center" itself while negotiating the ramp.

(4) To make vehicle loading easy, it is desirable to have the end of the car very close to the ramp platform. It is also necessary to protect both the car and the ramp from impact damage when cars are being positioned at the ramp. As car designs vary (draft gear length, amount of end overhand, position of uncoupling lever, etc.), this protection cannot be reliably provided by fastening wheel stops to the track.

(5) The design in figure 8-4 incorporates a cut-out at the front of the ramp at the height of the car coupler. Behind the cut-out is a concrete block separated from the remaining ramp structure with cushioning (expansion joint) material.

This concrete bumper block allows reduces the likelihood of impact damage to the ramp.

(6) Other shock absorbing designs and devices can be used as well, including commercial railcar buffers. The designer should select the method best suited for the particular application. While the concrete bumper block could easily be incorporated into new construction, it might prove impractical during rehabilitation if the existing ramp platform will not be extensively modified.

(7) To permit wheeled vehicles to cross the gap between the ramp and the flatcar, spanner boards may be necessary; tracked vehicles do not require spanner boards. Thus, if fixed spanners are used, they should be detachable so that they will not interfere with the loading and unloading of tracked vehicles.

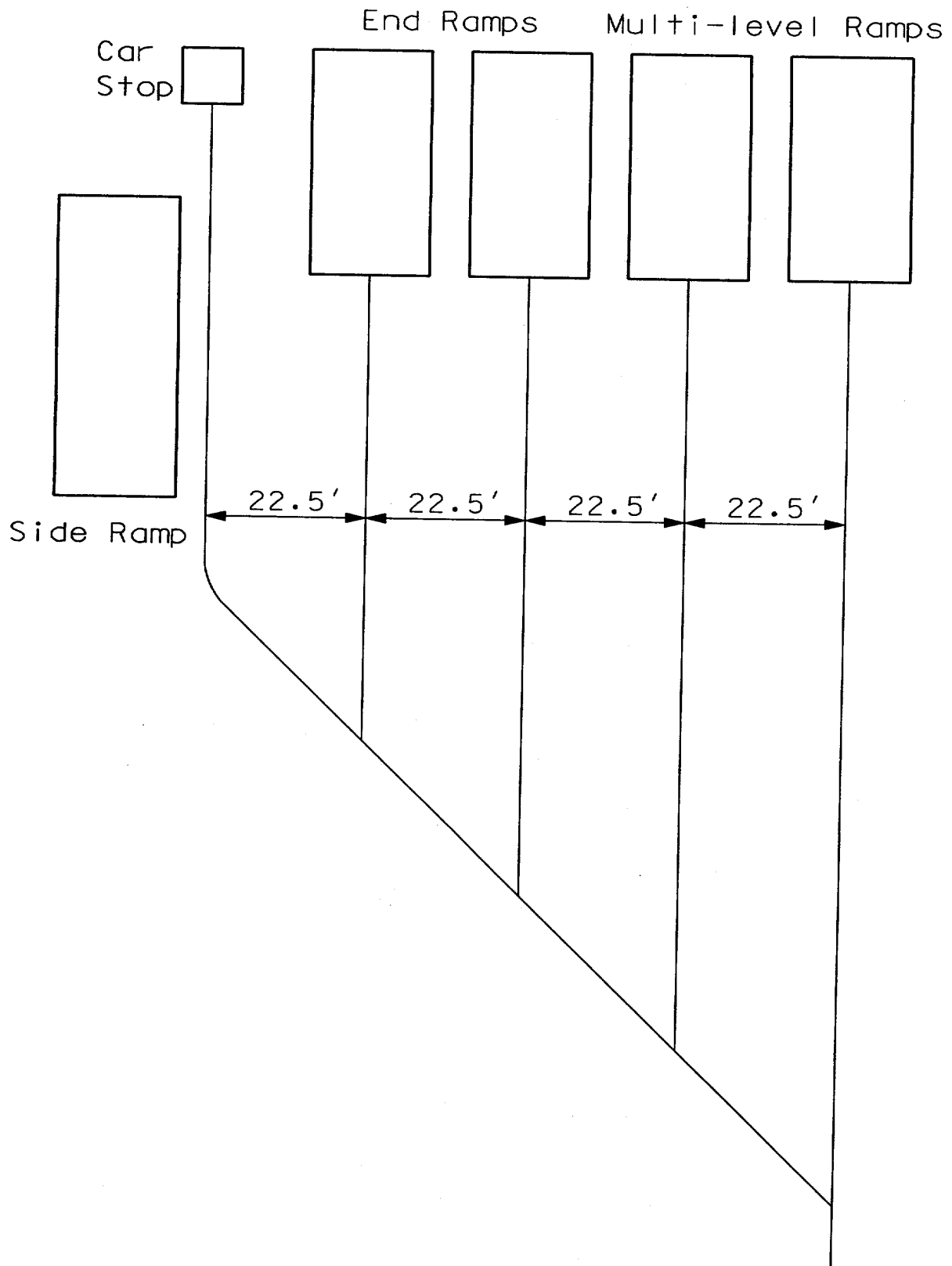

Figure 8-2. Vehicle Terminal.

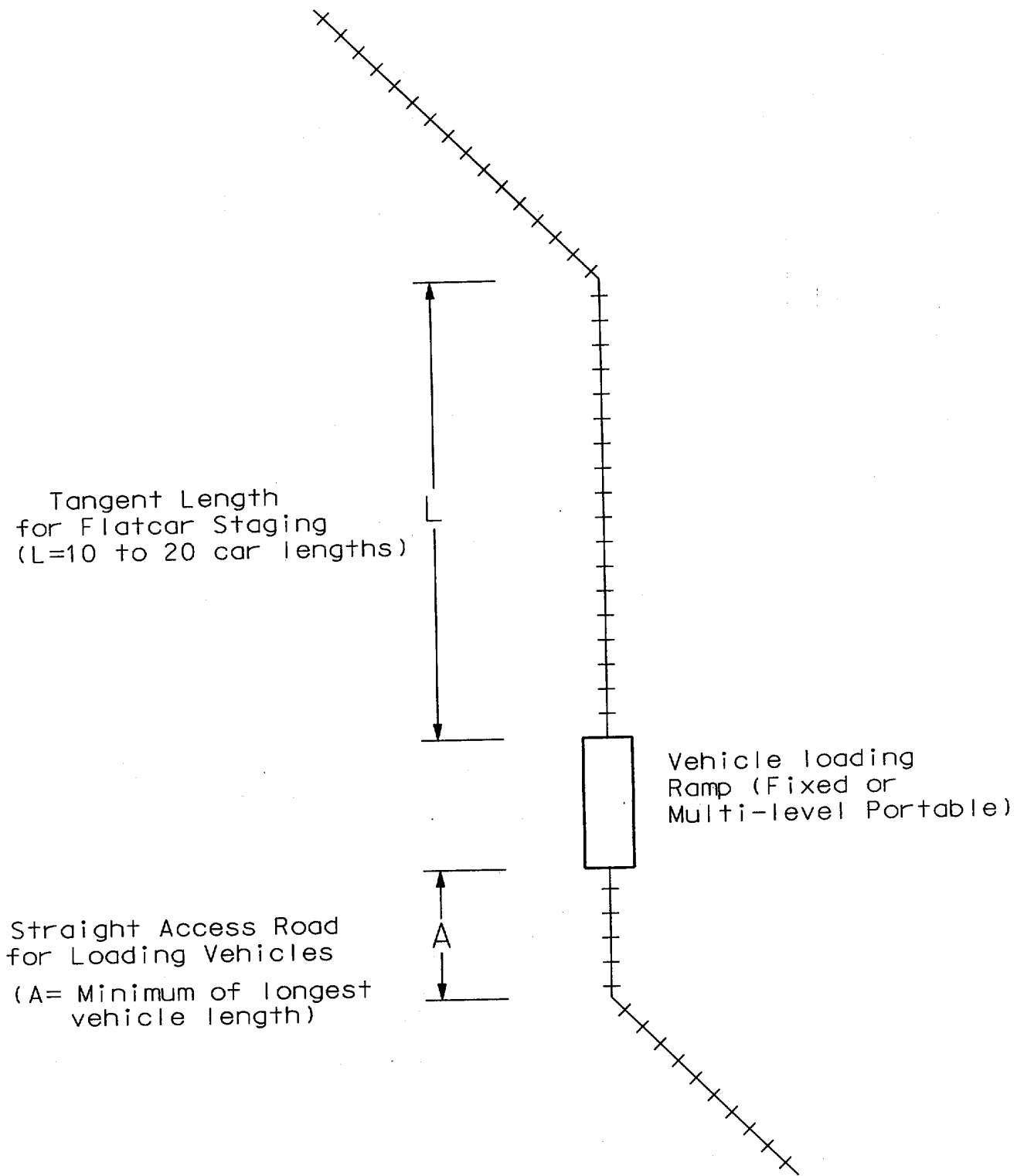
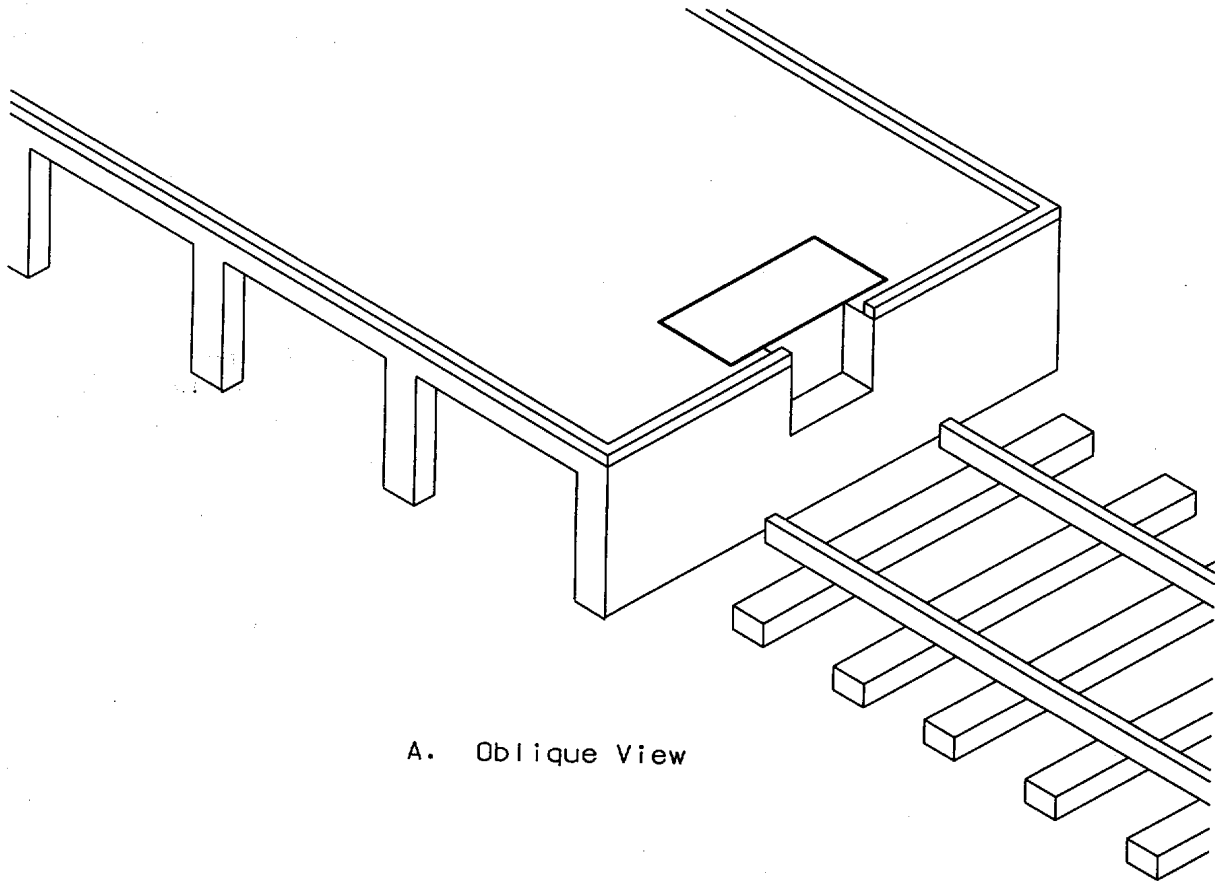
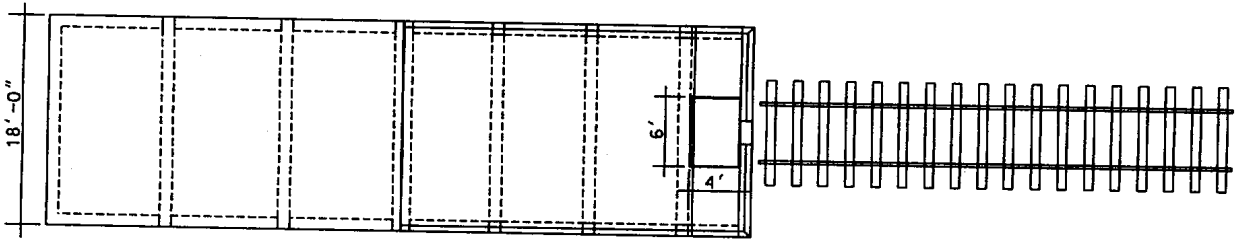

Figure 8-3. Track and Approach Road Lengths for Vehicle Loading.



A. Oblique View



B. Top View

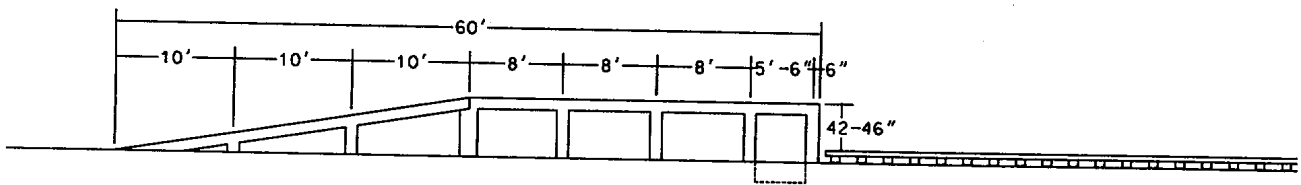

C. Side View

Figure 8-4. Concrete End Ramp.

f. Multilevel Ramps for Smaller Wheeled Vehicles.

(1) If an installation has a requirement to mobilize large quantities of small wheeled vehicles, it is recommended that multilevel ramps be used to load bilevel and trilevel railcars. These ramps are portable pieces of equipment that can either be purchased and maintained by the installation or leased from a commercial railroad when needed. Like end ramps, multilevel ramps are positioned at the end of a track spur. A typical multilevel ramp is shown in figure 8-5.

(2) It is important that the ground underneath a multilevel ramp be level and capable of bearing the weight of the ramp plus the heaviest vehicle being loaded. A portland cement concrete pad is recommended to ensure good ramp stability.

8-6. Break Bulk (Small Cargo) Terminals.

a. Permanent side ramps, parallel to the track are recommended for loading break bulk cargo into boxcars. For staging cargo, large open areas are needed surrounding the ramps. Thus, where, several parallel tracks run through a terminal, the ramps should be constructed along the outermost tracks.

b. Side ramps must meet the following design criteria: (1) The ramp must be capable of supporting the weight of a fully loaded 4,000 pound forklift.

(2) The ramp platform must allow sufficient area for a forklift to maneuver.

(3) The ramp platform must be at a height

convenient for a forklift to drive into a boxcar on the adjacent track as well as into a truck docked to the ramp.

(4) The ramp incline angle must be small enough for a forklift to easily negotiate it.

c. Figure 8-6 shows a diagram of a reinforced concrete side loading ramp.

8-7. Container Terminals.

a. A container loading area includes at least one track spur with sufficient space on one or both sides of the track for a container handler to operate. The required size of a container terminal is related primarily to the largest volume of cargo that must be handled in the shortest time period.

General plans and additional design guidance for container terminals can be found in the AREA manual.

b. A container terminal should meet the following design criteria:

(1) Include at least one straight spur track long enough to hold a minimum of 5 flatcars.

(2) Have one entrance and one exit to the yard area located to establish a one-way circular traffic flow.

(3) Have sufficient open area for a Rough Terrain Container Handler (RTCH) to efficiently operate.

(4) Have a surface which will support the weight of a RTCH carrying a loaded 40' container.

(5) For night operations, have "Parking Lot" type lighting positioned so that the light poles will

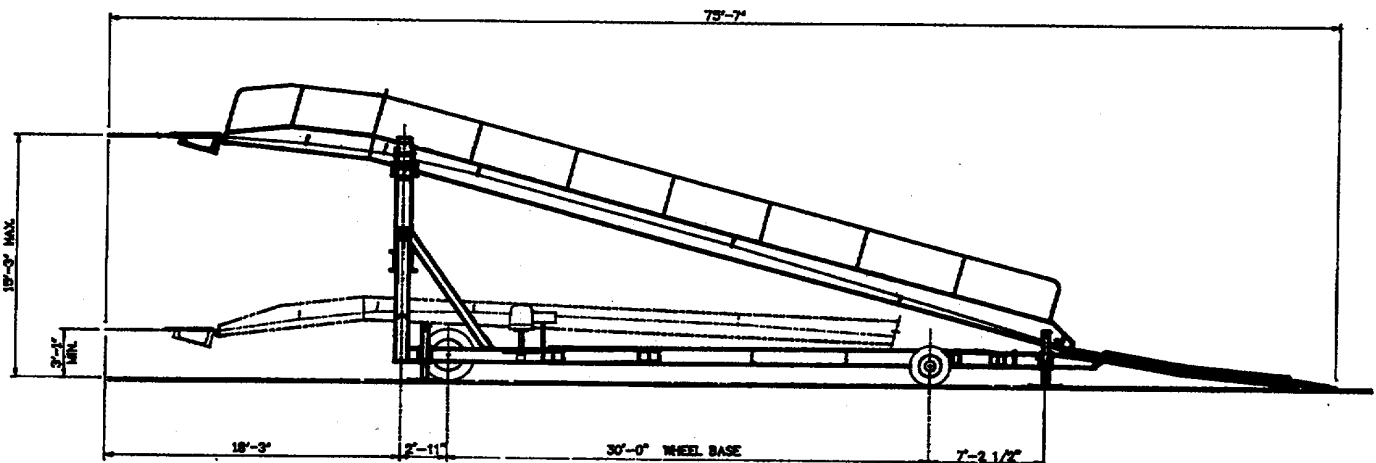

ELEVATION

Figure 8-5. Portable Multilevel Ramp.

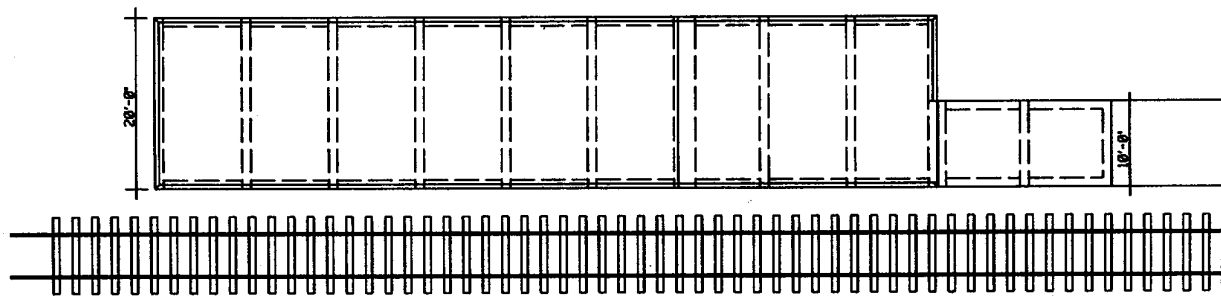
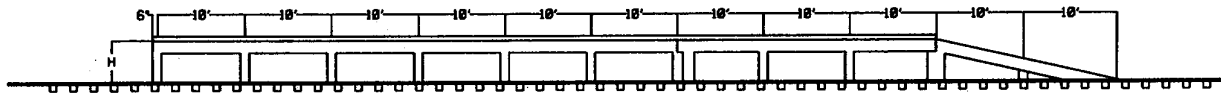
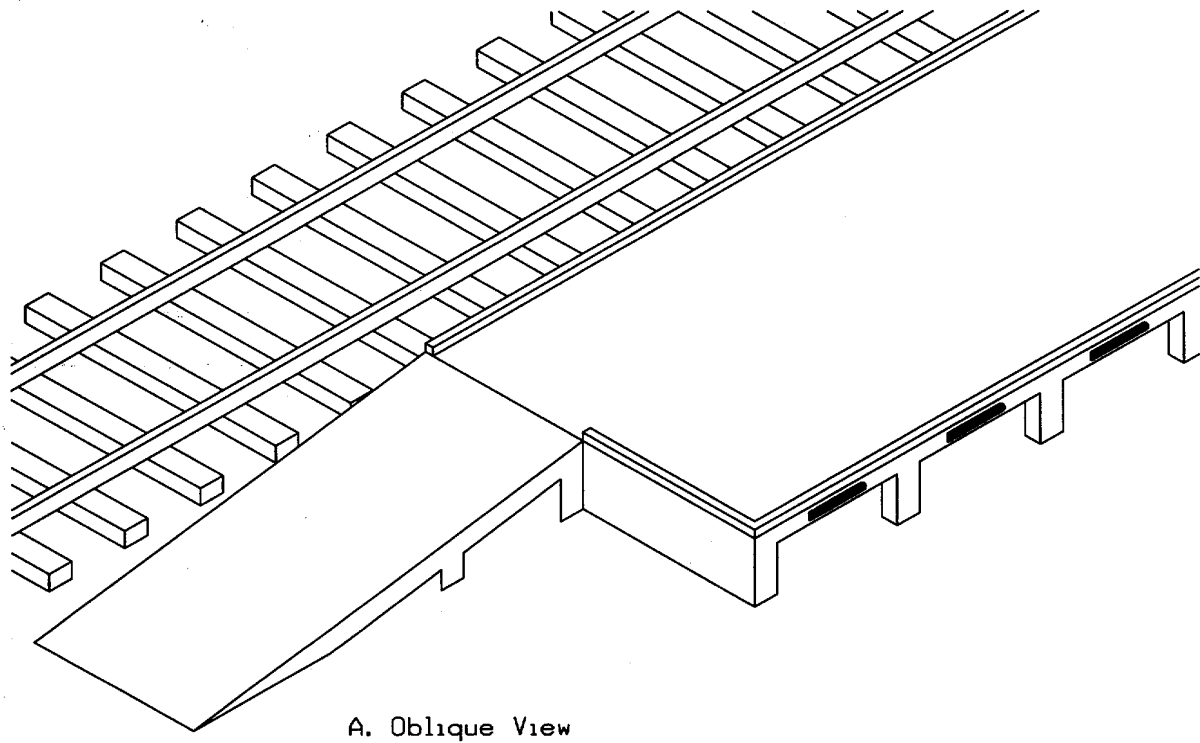

Figure 8-6. Concrete Side Ramp. not interfere with the operation of the RTCH or truck-trailers operating inside the yard.

(6) If a secured area is required, have a perimeter fence with a sally port across each track entry and exit. (See para 813).

8-8. Ammunition Terminals.

a. An ammunition terminal should be designed to meet the required shipping volume at the installation. The terminal may be set up as either a break bulk terminal (para 8-6) or a container terminal (para 8-7).

b. In addition to the usual terminal requirements, the following safety standards must be incorporated into the design.

(1) Generally, yards will be laid out on a unit car-group basis with each car-group separated by the applicable above-ground magazine distance.

(2) If the yard is formed by two parallel ladder tracks connected by diagonal spurs, the parallel tracks and the diagonal spurs will be separated by the applicable above-ground magazine distance for the unit-group quantities of high explosive.

(3) If the yard is a tree arrangement, consisting of a center ladder track with diagonal dead-end spurs projecting from each side at alternate intervals, the spurs shall be separated by the applicable above-ground distance for the net quantity of high explosives in the cars on the spurs.

(4) Railroad yards will be separated from other facilities by the applicable Quantity-Distance standards.

c. The following recommendations also apply to ammunition loading areas:

(1) If loaded ammunition cars will stay in a terminal area for sufficient time, the areas should be completely fenced, with sally ports across all tracks entering the area, and have locking pedestrian and vehicular gates. (See para 8-13.)

(2) The area should be lighted with "parking lot" type lighting.

(3) If guard towers are required, they should be positioned to allow observation of the entire ammunition loading area.

8-9. POL Terminals.

a. The design of POL handling and storage areas is regulated by Federal, state, and local environmental protection agencies as well as state and local fire marshalls. These agencies should be contacted when designing POL facilities so that the appropriate standards can be incorporated into the design.

b. POL handling and storage areas should be completely fenced, with sally ports across all tracks entering the area, and having locking pe-

destrian and vehicular gates. (see para 8-13.) These areas should also be lighted with "parking lot" type lighting.

8-10. Car Interchange.

a. *Purpose.* The interchange area (or yard) consists of one or more tracks used for the transfer of cars between the installation's railroad and the connecting commercial carrier. These tracks are usually located at or near the junction of the two railroads.

b. *Arrangement.* An example car interchange yard is shown in figure 87. In this arrangement, one (or both) of the outer two tracks would normally be designated as a running track and left clear of cars. The other tracks would be of sufficient combined length to handle the largest expected number of cars to come in or go out at any one time.

c. *Running track.*

(1) An open running track through the interchange yard will allow the installation's or commercial railroad's engine access to either end of each interchange track, and otherwise leaves an unblocked connection between the two railroads. The running track can also be used temporarily for switching. This would make it easier to rearrange the cars, if needed, or to pull out selected cars from any track.

(2) At installations with frequent grade crossings or where at least one heavily traveled road crosses the tracks at grade (especially if the crossing angle is less than 45 degrees), access to either end of a cut of cars is usually required. This will permit the engine to always be at the front of a train (pulling the cars rather than pushing), in either direction of travel-providing much better visibility and safety at road crossings.

d. *Set-Out Track.* It is sometimes useful to allow an additional track (or perhaps a short spur) at an interchange yard for special over-size loads and for cars needing repair-which should be placed only at the end of a train, or for other special movements which need separate handling.

e. *Derails.*

(1) In addition to being good practice, the connecting carrier will usually require that a derail be placed on the track leading to its line, along with a sufficient safe length of track between the detail and the junction. The derail is intended to prevent cars from accidentally rolling onto (or blocking) the carrier's track. As an option, derails may be desirable at the installation end of the interchange tracks.

(2) While derails themselves are not a design issue, their location is. Without a sufficient length

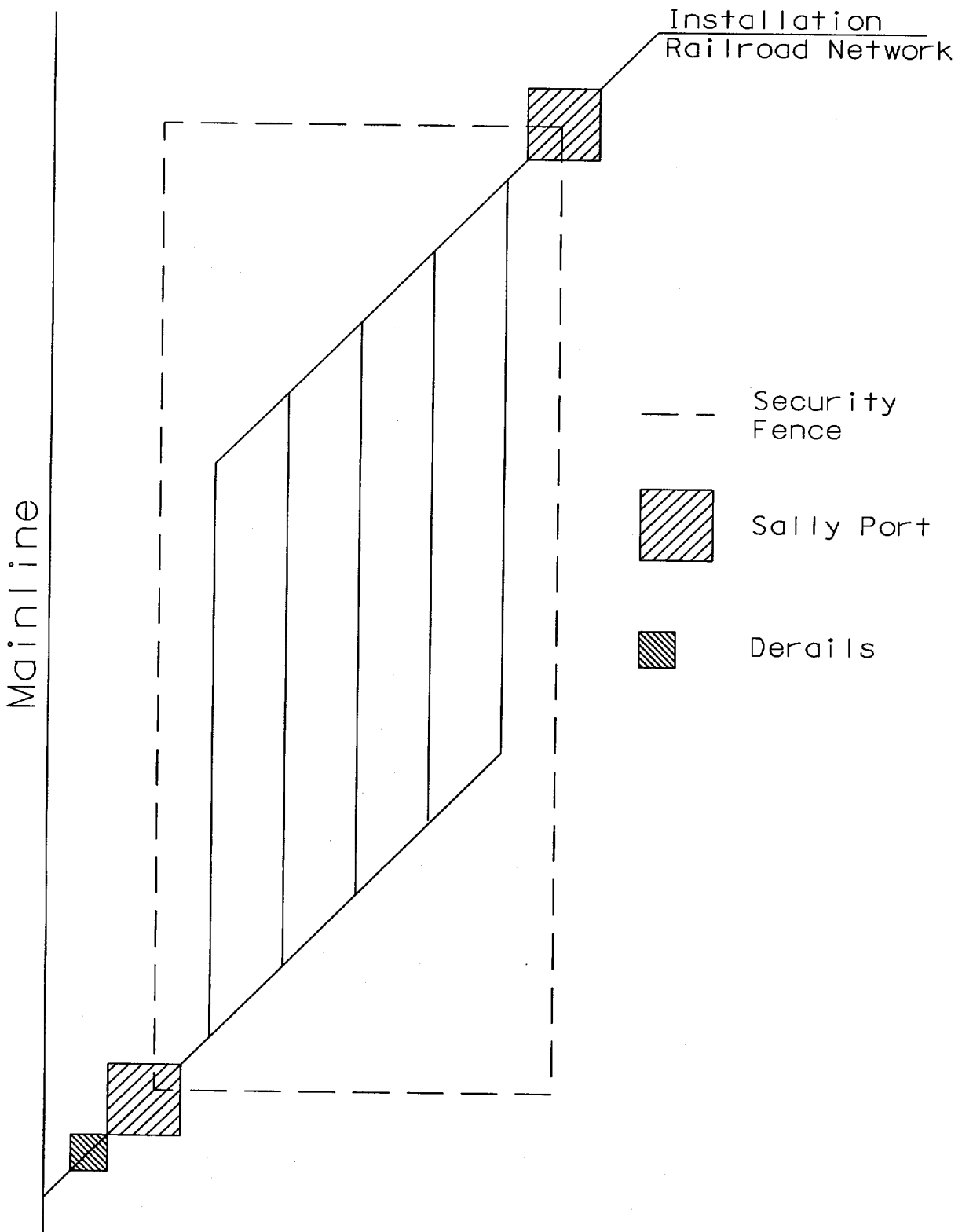

Figure 8-7. Interchange Yard

of track between a derail and the clearance point of the track being protected, a derail will be nearly useless. The designer must allow for this safe track length as an addition to the length of track required for car holding and switching space.

(3) The safe track length needed past a derail will vary with the grade of the yard tracks and the configuration of the junction area. The designer should consult the connecting commercial carrier's engineering department for guidance on placing a derail to protect their track.

f. Security. If the interchange yard is outside the main installation area or otherwise not located within constant view, it is recommended that the area be completely enclosed with a security fence, including lockable sally ports across the tracks. (see para 8-13.) Lighting and guard towers may also be required if security-sensitive cargo is regularly handled.

8-11. Yard, Storage, and Other Auxiliary Tracks.

a. Intended Use.

(1) Yard and storage tracks are intended for, respectively, the short and long term holding of cars. Yard capacity is needed at least equal to the maximum number of cars which the installation is expected to handle at one time. Storage capacity must at least accommodate the number of cars to be kept at the installation over a longer term. Loading tracks are not considered available for storage, unless cars are pre-positioned on them for loading.

(2) Auxiliary tracks include sidings, wyes, balloon tracks, crossovers, tail tracks, and other tracks used for switching and maneuvering cars, allowing engines and cars to clear the main track for other movements (as in a second engine switching or delivering cars), or to allow an engine to get around the other side of a string of cars.

b. Yard Tracks.

(1) Especially where the interchange with the commercial carrier is several miles from the loading sites, or where loading sites are within a separate and secure area, a yard may be required. A yard is typically several parallel tracks, as in figure 8-1, which serve as a holding area for cars waiting to be loaded or delivered to the interchange area.

(2) An example is used here of an installation with a mobilization plan calling for 60 loaded cars to be picked up each day (and 60 empties to be delivered) by the commercial carrier, and with loading sites (12 miles from the interchange point) which can accommodate 30 cars at one time. This installation will likely need a yard which will hold

at least the second 30 cars waiting to be loaded, and subsequently, the first 30 after they are loaded-to make room for the second 30 at the loading sites.

c. Storage Tracks. Storage tracks or a storage yard may appear as shown in figure 8-1, but are often designed as spur (dead end) tracks off a single ladder, as indicated in figure 7-5. (It is usually not essential to have access to either end of cars in storage, thus saving the cost and maintenance of turnouts at one end of storage tracks.)

d. Auxiliary 'Racks.

(1) Figure 8-8 shows common auxiliary tracks; their application is explained below.

(2) Sidings are used for temporarily holding extra cars, or holding part of a string of cars while the rest are being switched, or to allow an engine to get around to the other end of a string of cars.

(3) Crossovers can be used as a shortcut between routes or to allow an engine to get around a string of cars. In figure 8-8, the crossover, for example, allows trains from the interchange yard access to the siding without having to go south to the warehouse track and then back north again-thus the crossover allows the siding to be conveniently used from either track. In addition, when handling a string of cars longer than will fit on the siding, the cars may be left south of the crossover on either track, with the engine then using the crossover to get to the other track and then around to the opposite end of the cars.

(4) At least one wye or balloon track is almost always needed at military installations. These tracks allow engines and cars to be turned around. This capability is required for most effective use of vehicle terminals. If cars are delivered to the installation such that the vehicles on them would be facing away (backward) from the loading ramps, the cars need to be turned so the vehicles can be driven in a forward direction off the cars. Of the two types of turning tracks, wyes are most common, as they require far less space than balloon tracks. Balloon tracks are typically used if space allows them to conveniently encircle other facilities, thus not requiring a large land area just for the balloon track. Balloon tracks have the advantages over wyes of requiring only one turnout and a single movement to accomplish the turn. Wyes require a backward movement to complete a turn, as well as throwing more switches. Wyes are often created by installing the third leg where a junction already exists (or is required). In figure 8-8, for example, the wye also allows convenient access to the warehouse track from either north or south directions.

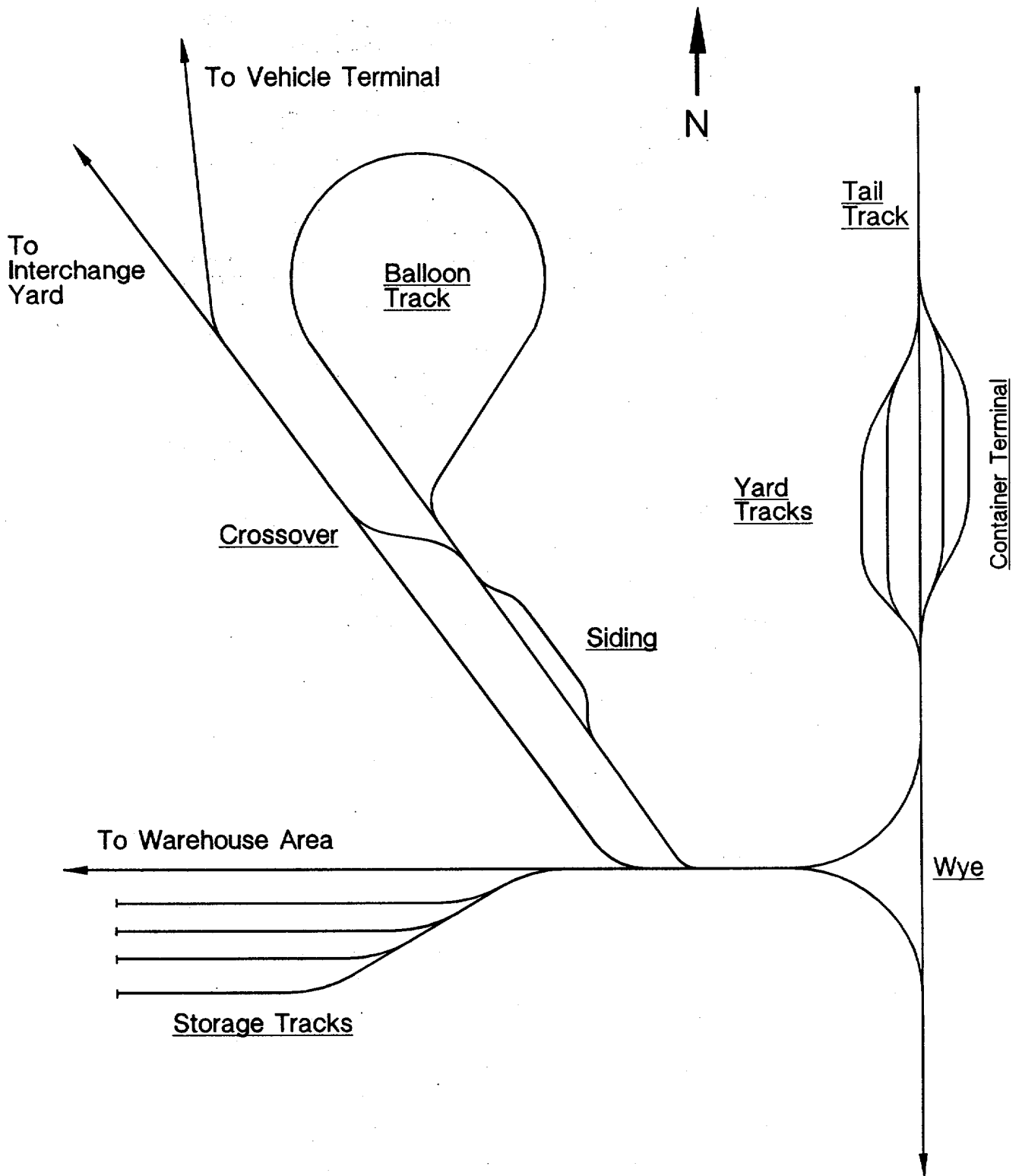

Figure 8-8. Auxiliary Tracks.

(5) When a yard or siding is located near the end of a route, a tail track is often added to allow switching from the far end of the yard or siding. A tail track is most useful if it is at least three car lengths longer than the siding or the longest track in the yard. Figure 8-8 shows a tail track north of the container terminal.

8-12. Miscellaneous Buildings.

a. Purpose. In each terminal area buildings may be needed for storage, shelter, and for other purposes. At vehicle terminals, buildings will be needed for a crew and communications facility and for blocking and bracing storage.

b. Crew and Communications Facility. The following should be considered when designing a crew and communications facility:

(1) The building should be located as close to the loading area as possible without interfering with the flow of vehicles between the staging areas and the loading ramps.

(2) The building should be large enough to accommodate the billeting of a rail loading crew.

(3) A telephone and a public address system would facilitate better command and control.

c. Blocking and Bracing Storage Facility. The following should be considered when designing a blocking and bracing storage facility:

(1) The building should be located as close to the loading tracks as possible. Co-location with the crew and communications facility may be desirable.

(2) The building needs to be large enough to hold the blocking and bracing material required for one cycle of rail loading, that is, enough material for the maximum car capacity of the terminal.

8-13. Security Fencing.

a. Requirement. Security fencing may be required to surround facilities within a terminal, or even a complete terminal area. These fences are typically standard chain-link construction (i.e. 6-foot FE-5), however a more secure fence (FE-6 or FE-7) may be needed. The installation Physical Security Officer should be consulted to ensure that proper security requirements are considered in the design. All gates and sally ports should be equipped with locking hardware.

b. Sally Ports When designing a sally port, the following should be considered: (1) The sally port must prevent unauthorized entry by both pedestrians and vehicles.

(2) The sally port must open to a minimum width of 17 feet to allow cars to pass through.

(3) Culverts draining the track through a sally port should have security bars in them.

(4) It is recommended that a drainage ditch security barrier be constructed using concrete. This will provide both a headwall for the culvert and a foundation to mount rollers for the sliding gate.

CHAPTER 9
CONSTRUCTION

9-1. Construction Survey.

a. The intent of the construction survey is to mark the route to guide construction. It may be done in two stages, especially in areas where significant amounts of earthwork and grading needed. In the first stage, enough mark are placed to define the basic track grade and drainage ditches. During this stage, culvert locations should be checked to ensure that final track elevation will allow room for sufficient cover over the culverts.

b. In the second stage, stakes are set for final grading and construction, including spiral and curve locations, grade and side slope markers, bridge abutments, culvert centerlines, and frog and switch point locations for turnouts. It is best to set stakes only a short time before they will be needed, to minimize the chances of them being disturbed. Guidance on stake setting is given in table 9-1.

Table 9-1. Suggested Stake Intervals for Final Survey

Track Category	Suggested Stake Interval (feet)
Tangents	100
Curves: up to 3 degrees	100
3 to 6 degrees	50
over 6 degrees	25

9-2. Inspecting Materials.

a. *Inspect Before Installation.* It is recommended that all materials (new or secondhand) be inspected before work begins. If there are question concerning the materials, it is much better to handle them before the material has been installed.

b. *Ties.* Although inspection of the ties at the plant is preferred, this is not always possible. However, upon delivery to the project site, all ties will be inspected to ensure compliance with the project specifications. Ties not meeting the specifications will be rejected. The inspector should receive a copy of the treatment report from the treatment plant and check that a date and manufacturer's brand are present on the ties.

c. *Relay Rail.* When relay rail is bought for the project, it will be inspected for wear and external defects (end batter, engine burns, etc.), per the project specifications. Standard gages are available for checking wear.

9-3. Saving Salvageable Materials.

a. When removing rail and other track material (OTM) for stockpile at an installation or transfer to another installation, rail of like weight and section (and OTM of like size and design) should be stacked neatly together. Normally, spikes will not be salvaged.

b. Care should be taken when removing rail and OTM to prevent damage to usable materials. A torch should never be used to cut rail, joint bars or other salvageable materials during removal.

9-4. Subgrade and Drainage.

a. *Subgrade.* The subgrade will be inspected during each stage of preparation.

b. *Handling and Installing Geotextiles.*

(1) The maximum time for exposure of geotextiles to sunlight, from removal of the protective shipping cover to final placement, should be no more than seven days.

(2) Equipment should not be allowed to operate over an area covered with geotextile unless there is at least a 6-inch cover of sub-ballast or ballast.

(3) Surface drainage should be directed away from geotextile material to help prevent contamination.

(4) The minimum overlap distance in the longitudinal and transverse directions should be 3 feet.

c. *Drainage.*

(1) Drainage and other earthwork near the track should be completed before final subgrade preparation begins; this minimizes the likelihood of disturbing the final subgrade surface or getting soil in the ballast, and also provides a properly draining work site.

(2) Subdrainage installations should be checked before being covered and ditch elevations and sections checked before track work begins.

9-5. Track Construction.

a. *Sub-ballast Placement.*

(1) On new construction, the subgrade surface should be inspected before geotextile or sub-ballast the is placed.

(2) Sub-ballast is placed on the prepared subgrade and compacted to provide a working surface for track construction. Sub-ballast should be placed to the lines of grade shown on the

project plans and compacted to 95 percent of ASTM D 1557 laboratory maximum dry density.

b. Track Construction Sequence. Typical track construction sequence is as follows:

- (1) Place ties on the sub-ballast at the required spacing.
- (2) Place tie plates on the ties.
- (3) Place the line rail on the tie plates and spike in place.
- (4) Install joint bars and tighten bolts.
- (5) Install the opposite rail by first checking the gage and spiking every fourth tie and then spiking the remaining ties.
- (6) Install rail anchors at this stage, or after final surface (but before dressing ballast).
- (7) Unload and distribute ballast.
- (8) List and tamp track to about 1 inch below final elevation, in 3-4 inch lifts, adding ballast as needed after each lift. The tamping machine will also align the track and place the proper superelevation in the curves during this operation.
- (9) Check grade and line stakes, and clearances.
- (10) If practical, run over track with at least 10 passes of an engine (or engine with heaviest loaded cars) before the final surface.
- (11) Raise track to final surface.
- (12) Dress (shape) ballast section.

c. Ballast Unloading.

- (1) Large amounts of ballast (several hundred tons or more) are most efficiently unloaded using railroad hoppers. For installations having a loco

otive, the provision of a government locomotive and crew to move the ballast cars for the contractor may result in a lower unit cost for ballast distribution. Appropriate arrangements should be provided in the contract documents and during the preconstruction meetings to insure effective use of government locomotive to assist the contractor in ricing the ballast.

(2) When trucks or other automotive equipment are used to place ballast, care should be taken to prevent rutting that would impair drainage of the sub-ballast or subgrade. Any ruts that are formed should be leveled and graded to drain prior to the continuation of ballast placement.

d. Rail Installation.

(1) Rails should be laid one at a time with allowance for expansion provided between the rail ends in accordance with table 9-2.

(2) Gaps between rail ends and insulated joints should only be sufficient to permit insertion of standard end posts.

(3) During rail laying a standard rail thermometer should be used to determine the rail temperature. The thermometer should be laid close to the web on the side of the rail base which is shaded from the sun, in advance of the laying operation and left there long enough to accurately record the temperature.

e. Installing Relay Rail.

(1) When relay rail is used, care should be exercised in matching adjacent rails to minimize joint mismatch. Any mismatch at the rail ends

Table 9-2. Rail Joint Gap.

Rails up to 33 feet long		Rails 39 feet to 160 feet long	
Rail Temperature (Fahrenheit)	Rail End Gap	Rail Temperature (Fahrenheit)	Rail End Gap
Below -10	5/16	Below 6	5/16
-10 to 14	1/4	6 to 25	1/4
15 to 34	3/16	26 to 45	3/16
35 to 59	1/8	46 to 65	1/8
60 to 85	1/16	66 to 85	1/16
Over 85	None	Over 85	None

must be ground or welded to provide proper match. Building up a worn end by welding may only be done by people with the proper training, experience, and equipment to perform this operation.

(2) Relay rail will be laid with the previous gage side facing out (old field side becoming the new gage side) unless required to match existing wear patterns. Where either overflow or a nearly square edge is left on the new gage side, this edge must be ground to a rounded profile-similar to that found on new rail.

f. Surfacing and Lining.

(1) During the surfacing operation, every tie should receive two full insertions of the tamping heads at each lift. The joint ties, on the joint side only, should get an additional insertion.

(2) If raising the track creates voids under the tie centers, the void space should be filled lightly but not tamped.

(3) Worn tamping feet on a tamping machine will not properly compact ballast under the ties.

(4) Ties which pull loose during surfacing should be lifted and plugged or replaced, spiked or retamped.

(5) Track at the ends of open deck bridges should be maintained at the same grade as the track on the bridge for at least 25 feet beyond bridge abutments and then transition smoothly to meet established track grades.

(6) Track should not be tamped if snow cover is present or in frozen ballast conditions.

g. Switch Stand Installation. The switch stand is normally installed so that when the switch is lined for the normal (main) route, the connecting

rod keeps the point closed with a pulling (rather than a pushing) force. In most cases, this will mean installing the stand on the diverging side of the turnout. When a ground throw stand is used, the handle should point toward the frog when the switch is lined for the normal route.

9-6. Quality Control/Quality Assurance

a. Many installations and offices do not have inspectors who are knowledgeable and experienced in railroad work. In these cases it is strongly recommended that inspection services be obtained from an engineering firm which specializes in railroad design and construction.

b. As initial work is often covered over in final stages, it is strongly recommended that railroad work be inspected throughout the process.

c. All relay rail should be ultrasonically tested after installation. Scheduling with a contractor specialized in this operation should be done well in advance to assure availability at the least cost.

9-7. As-Built and Final Drawings.

Upon completion of construction, a set of red-line drawings should be given to the installation engineer. Final as-built drawings will be produced showing the actual track locations, grades, curvatures and complete curve data, rail weight and section, grade crossing locations and types, crossing signal circuitry and layout, drainage structures, and other aspects of track construction. These drawings will be given to the installation engineer within six months after construction has been completed.

**APPENDIX A
REFERENCES**

Government Publications

Army.

AR 420-72 Pavements, Railroads, Bridges and Associated Appurtenances

Army/Air Force.

TM 5-628/AFJMAN 32-1048 Railroad Track Standards

TM 5-8204/AFJMAN 32-1016 Drainage for Area Other than Airfields

TM 5-822-2/AFJMAN 32-1018 General Provisions and Geometric Design for Roads, Streets, Walks and Open Storage Areas

TM 5-822-14/AFJM 32-1019 Soil Stabilization for Pavement

TM 5-8526/AFR 88-19, Vol. 6 Arctic and Subarctic Construction Calculation Methods for Determination of Depths of Freeze and Thaw in Soils

Federal Highway Administration (FHWA) 400 Seventh Street, SW, Washington, DC 20590

Manual on Uniform Traffic Control Devices for Streets and Highways

Railroad-Highway Guide Crossing Handbook

Non-Government Publications

American Railway Association (AREA): 50 F Street NW, Suite 7702, Washington DC 20590

Signal Manual of Recommended Practice, Washington, D.C.

Manual for Railway Engineering, Volumes I and II, Published Annually, Washington, D.C.

Portfolio of Trackwork Plans, Published Annually, Washington, D.C.

American Society for Testing and Materials (ASTM) 1916 Race Street, Philadelphia, PA 19103

C 33 Concrete Aggregates

D 1241 Material for Soil-Aggregate Subbase, Base and Surface Courses

D 1557 Laboratory Compaction Characteristics of Soil Using Modified Effort

American Wood Preservers Association (AWPA) P.O. Box 286 Woodstock, MD 21163

American Wood Preserver's Association Standards

Hay, William W. 1982. *Railroad Engineering*. John Wiley & Sons, New York, NY

APPENDIX B

RULING GRADE-EXAMPLE PROBLEM

B-1. This example of determining a trail ruling grade for a new railroad line follows the mat presented in paragraphs 3-4, 3-5, and 3-6.

B-2. A railroad line is to be built from terminal serving the new training area at Example to the nearest commercial railroad, a 15 miles away. The most critical traffic, heaviest loads, will be M-1 tanks on flat (Each car is 70 feet long and has a maximum loaded weight of 187 tons riding on 6 axles). The installation has one 1,500 HP, 100 ton locomotive

B-3. To handle movements during larger training exercises and mobilization, the installation w to use an engine from the connecting rail which will be capable of hauling 25 loaded over the line at 15 MPH average speed. The connecting railroad expects to have a 3,000 170 ton (340,000 pound) locomotive available when needed. (Tractive effort curves are not available for either locomotive. For simplicity, let locomotive length equal car length.)

B-4. The designer must now determine the n mum effective gradient (and grade length) on new line to accommodate these train movements:

- a. *For the commerical locomotive.*
 - (1) Traction Limit = $340,000 / 4 = 85,000$
 - (2) Tractive Effort at 15 MPH = $300 \times 3,000 / 15 = 60,000$ lbs.

Engine power governs usable tractive effort.

- b. *Ruling Grade.*
 - TE = 60,000 lbs
 - $W_{Eng} = 170$ tons
 - $W_{Car} = 187$ tons
 - $N_{car} = 25$
 - $G = 60,000 / 20(170 + 25 \times 187) - 0.15 = 0.47\%$
 - Grade length = 26 (engine and cars) x 70=1820 Feet (or longer)

Thus, grades of 1820 feet or longer would has be limited to an effective gradient of 0.47%.

B-5. From a brief review of contour maps of the area through which the route would run, the designer believes the route may require grades much steeper than 0.47% to keep construction costs at an acceptable level.

B-6. One way to accommodate the desire to l single trains of 25 loaded flats at an average speed

of 15 MPH and allow for a steeper ruling grade is to use the installation's engine and commercial engine together and drop the travel speed up the ruling grade to 10 MHP, which should further increase the tractive effort available. To offset the out loss in speed up the ruling grade, other portions of the route might be constructed to accommodate higher speeds-perhaps 25 to 30 MPH. A check of this possibility shows the following:

- a. *For the commercial locomotive.*
 - (1) Traction limit = $340,000 / 4 = 85,000$ lbs.
 - (2) Tractive Effort at 10 MPH = $300 \times 3,000 / 10 = 90,000$ lbs.

Traction limit governs usable tractive effort.

- b. *For the installation's locomotive.*
 - (3) Traction limit = $200,000 / 4 = 50,000$ lbs.
 - (4) Tractive Effort at 10 MPH = $300 \times 1,500 / 10 = 45,000$ lbs.

Engine power governs usable tractive effort.

- c. *Ruling Grade.*
 - TE = $85,000 + 45,000 = 130,000$ lbs.
 - $W_{Eng} = 170 + 100 = 270$ tons
 - $W_{car} = 187$ tons
 - $N_{car} = 25$
 - RR = 3 lbs/ton
 - $G = 130,000 / 20(270 + 25 \times 187) - 0.15 = 1.16\%$
 - Grade length = $27 \times 70 = 1890$ Feet (or longer)

Thus, if this revised arrangement is acceptable, grades of 1890 feet or longer could have an effective gradient as high as 1.16%. Table B-1 shows the curve compensation for curves on this grade.

Table B-1. Curve Compensation for a 1.16% Grade.

Degree of Curve	Uncompensated Grade		Compensated Grade	
	Actual	Effective	Actual	Effective
1	1.16	1.20	1.12	1.16
2	1.16	1.24	1.08	1.16
3	1.16	1.28	1.04	1.16
4	1.16	1.32	1.00	1.16
5	1.16	1.36	0.96	1.16
6	1.16	1.40	0.92	1.16

d. From the table, if a 5 degree curve was located within the ruling grade, the constructed (actual) gradient through that curve must be limited to 0.96% to keep the effective gradient within 1.16%.

APPENDIX C

TRACK (1.0): TRACK DESIGN AND EVALUATION FOR WORK PLANNING AND BUDGETING DESCRIPTION AND EXAMPLE

C-1. Introduction

a. The TRACK program is intended for the structural evaluation of existing track, or of a new design. TRACK is designed for lower speed railroads with light to moderate traffic volumes, as is the case at most military installations. It provides an evaluation of vertical track support for a given wheel load and was developed to serve two main purposes:

(1) To provide an estimate of the suitability of an existing track or new track design to handle its expected loading.

(2) To permit an initial look at the effects of changes in an existing track or new track design—either improvements or deterioration.

b. More specifically, the program is intended to help answer the following questions:

(1) Are there weaknesses in the existing track system? (2) If no weaknesses are apparent, how much deterioration can occur before weaknesses do appear? (How much "reserve capacity" is there?)

(3) If weaknesses are apparent, which track system components are deficient?

(4) How serious are the deficiencies?

(5) What improvements will eliminate the deficiencies?

c. Use of this program should be considered only a first step in checking the capability of existing track, a new design, or in examining rehabilitation alternatives. The program is not a substitute for railroad engineering expertise; it is 'one tool of several that should be used in any thorough examination of the track system and design or rehabilitation alternatives.

C-2. Screen Arrangement and Program Operation.

a. A sample main menu screen is shown in figure C-1. The main menu is in the upper left. Choices 1 through 5 lead to a sequence of screens which ask questions about load and track characteristics. To use the program, select items 1 through 5 in succession and respond to the questions. All questions must be answered for results to be generated.

b. The questions require using the up or down ARROW keys to select from a list or typing an

appropriate answer in the space provided. In either case, push the ENTER key afterward to input the information into the program. At any time, the user may back up to a previous question using the ESC (escape) key. One question in item 3 (Ties and Plates) requires using the map in figure C-2.

c. As items 1 through 5 are completed, the chosen input values for the equations are shown in the box on the right. Once items 1 through 5 are all complete, the program automatically performs the calculations and displays the results in the bottom box.

d. Main menu item 6 allows saving a trial case (all the selected answers, equation input values, and results) to a file, loading (retrieving) a previously saved trial case, or deleting a trial case. Item 7 will show a complete output report on the screen or send it to a printer. This report gives a listing of all the input describing the load and track characteristics for the trial case, as well as the analysis results. An example report is shown in figure C-3. Item 8 is chosen to exit the program.

e. The box to the right of the main menu shows the last input values that were used in solving the track analysis equations. (When the program is started, zero values automatically appear until the user provides input through choices 1 through 5 in the main menu.) f The bottom box shows the results from the last run. The first column of numbers are the calculated values, the second column shows suggested limits (for the type and condition of the track, as described), and the third column simply compares column 2 with column 1. Values less than 100% indicate adequate strength, with values over 100% indicating overload or overstress.

g. After changing information in any of the main menu items 1 through 5, the program automatically creates new input values of the track analysis equations, recalculates the equations, and returns to the main menu screen, which shows the revised input and results. Users may change one or all input values when re-running the track evaluation. While the program is active (on screen), all values not changed are taken from the last trial case.

Main Menu
1. Input for WHEEL LOADING
2. Input for RAIL
3. Input for TIES
4. Input for BALLAST
5. Input for SUBGRADE
6. Direct Input of Track Variables
7. Load, Save or Delete a Case
8. PRINT Results
9. Quit Program

Current Input Values and Results }			
[Input Values for TIE2.TRK]			
Rail Wt.	-	90.	lbs.
Rail I	-	38.7	in^4
Tie Spacing	-	22.0	in
Tie I	-	257.00	in^4
Tie E	-	1605615.	psi
Ballast dpth	-	12.0	in
Ballast E	-	34000.	psi.
Subgrade E	-	1890.	psi
Wheel load	-	31000.	lbs.

[Suggested Limits and Analysis Results]				
Description	Stresses and Loads	Suggested Limits	% of Limit	
Rail Bending Stress	13203 psi	26000 psi	51%	
Tie Reaction	15186 lbs	52236 lbs	29%	
Tie Bending Stress	1228 psi	1557 psi	79%	
Ballast Surface Stress	43.2 psi	54.6 psi	79%	
Subgrade Stress	8.94 psi	8.77 psi	102%	

Figure C-1. Main Menu for TRACK (1.0).

C-3. Use.

a. For new (or completely rebuilt) track, the designer should select track components which give stresses and loads below the suggested limits. However, as the program provides only approximate values, changes (or differences) of less than 10% should be considered as not very significant. Different alternatives may be generated, with the final selection made by considering economics, material availability, operating requirements, etc.

b. When answers to questions about the track are not well known, designers should pick the nearest likely minimum and maximum values. If the results change significantly between the two answers, additional investigation should be done to determine the most appropriate choice. If no significant change occurs, no additional investigation is required.

c. For characterizing the subgrade, the program allows several options. When only the soil classification is known, both the screen and the output report will note this as not as reliable as the other methods. When possible, the other methods should be chosen, with responses based on accurate information.

C-4. Example.

a. The following example illustrates a typical application of the TRACK program and the type of evaluation that should accompany the results. In

The example, it is as important to note the manner in which the program is used as it is to examine the numbers produced.

b. The DEH at Fort Example is told to start expecting regular traffic or fully loaded 140-ton flatcars at the installation. From inspection information and knowledge of the track, the following established:

(1) RAIL: 75 pound, in good condition with very little wear.

(2) TIES: The large majority are 6" thick and wide, in fair to good condition, with average spacing of 22". The most common defect (in the tie late area) is splits about 1 inch wide (through the whole depth of the tie).

(3) BALLAST: At the top, filling in between the ties, there is good, clean crushed rock, but this extends down only 6" below the bottom of the tie-which is what counts for load support.

(4) SUBGRADE: Medium-soft: acceptable, drainage is fair to good.

(5) WHEEL LOADS: 140-ton flatcars at 10 to 5 mph.

c. Figure C-3 shows the results of this initial case. If the 140-ton cars were to be regularly run over the existing track, ties, ballast, and subgrade would be significantly overstressed.

d. The DEH realizes that the 6" of real ballast under the track is insufficient, so a trial run is made to add an additional 6" to the track. Table '1 shows the results.

Decay Hazard Map of the United States

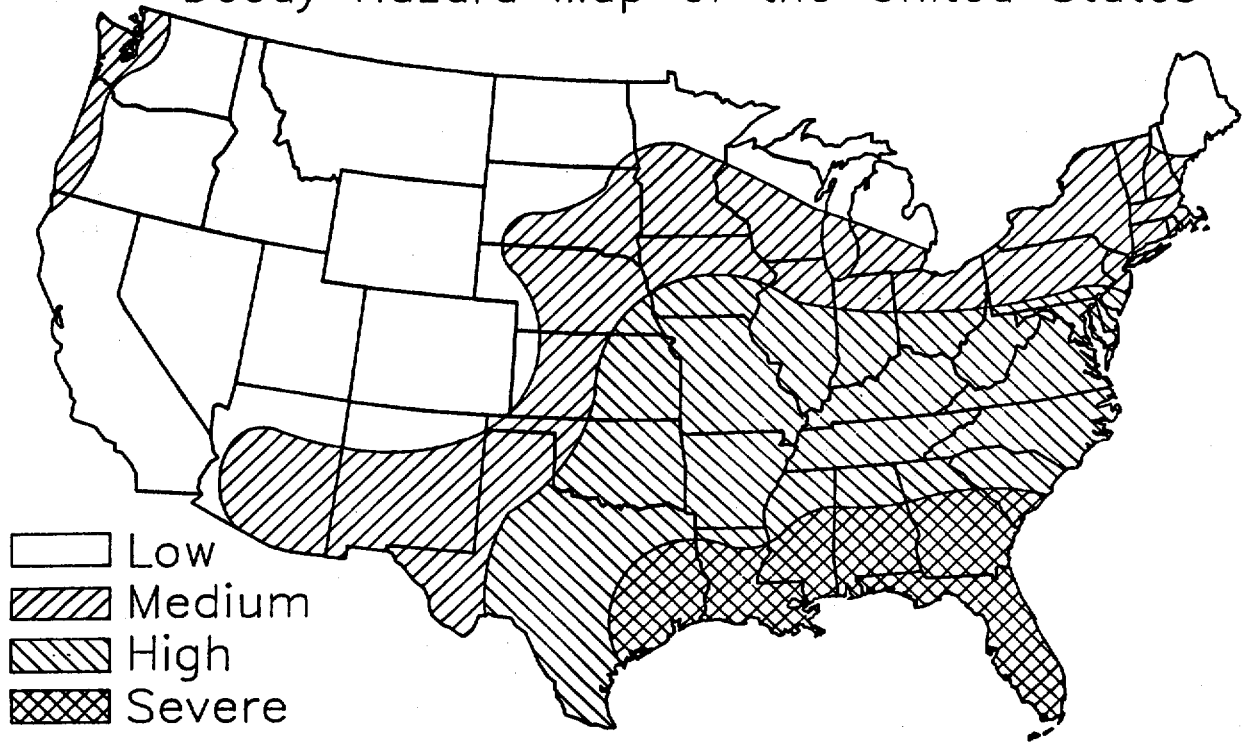

Figure C-2. Decay Hazard Map of the U.S.

Track Structural Evaluation Program Report 07-20-1994

Initial Case - Existing-Fort Example Track.
 Description of Track Conditions:

Track Loading			
Most common heavy car		Flat, 140 T	
Design wheel loading type.....		10 to 25 MPH	
Design wheel load (lbs)		38750	
Rail			
Rail weight (lbs/yd)		75	
Rail moment of inertia (in ⁴).....		23	
Ties			
Tie moment of inertia (in ⁴).....		135	
Tie modulus of elasticity (psi)		1082648	
Type of wood in ties.....		Hardwood	
Nominal dimensions of tie (in)		6 x 8	
Tie spacing (in)		22	
Dimensions of tie plate (in).....		11 x 7.5	
Tie Age (years)		15	
Decay hazard		medium	
Tie Moisture state		dry	
Most important tie defect		split tie	
Split width (in)		1	
Ballast			
Ballast Modulus of elasticity (psi)		37500	
Ballast depth (in).....		12	
Majority of ballast made up of.		> 50% larger than 1/2 inch	
Ballast moisture condition		dry	
Most common stone sizes		3/4" to 1 1/2"	
Percent fines		< 10%	
Shape of stones		angular	
***Subgrade* * *			
Subgrade modulus of elasticity (psi)		3000	
Bearing Capacity information source		Program	
Classification system used		DIRECT	

Track Stresses and Suggested Limits:

Description	Stresses and Loads	Suggested	Limits % of Limit
Rail Bending Stress	17800 psi	25000 psi	71%
Tie Reaction	20500 lbs	12600 lbs	162%
Tie Bending Stress	1580 psi	1050 psi	151%
Ballast Surface Stress	89 psi	61 psi	147%
Subgrade Stress	15 psi	15 psi	100%

Figure C-3. Report from TRACK (1.0).

Table C-1. Add 6" Ballast To Track.

	Stresses and Loads	Suggested Limits	% of Limits
Rail Bending Stress	17,800 psi	25,000 psi	71
Tie Reaction	20,500 lbs	12,600 lbs	162
Tie Bending Stress	1,580 psi	1,050 psi	151
Ballast Surface Stress	89 psi	61 psi	147
Subgrade Surface Stress	15 psi	15 psi	100

f. The results show that adding 6" of ballast does substantially reduce the subgrade stress, putting it at the allowable limit. However, ties and ballast are still overstressed, with tie bending stress and ballast surface stress slightly increasing (due to the stiffer ballast section of 12"). (Note: As the track characteristics are changed, the calculated stresses and loads and the suggested limits are likely to change. This behavior is a good illustration of the complex interaction of the track system components.)

g. Since the desired reduction in subgrade stress has been achieved by adding the 6" of ballast, the DEH decides to keep that change, at least temporarily, and add another improvement to see if tie and ballast stresses can be reduced. The DEH knows that 75 pound rail is very light, by commercial standards, so a trial is made to replace it with 115 pound rail-the lighter standard commercial rail. (Tie plate size will also increase to accommodate the larger rail.) Table C-2 shows the results.

Table C-2. Add 6" Ballast and Install 115 lb Rail.

	Stresses and Loads	Suggested Limits	% of Limit
Rail Bending Stress	12,300 psi	32,000 psi	38
Tie Reaction	17,600 lbs	14,200 lbs	124
Tie Bending Stress	1,380 psi	1,050 psi	131
Ballast Surface Stress	75 psi	61 psi	123
Subgrade Surface Stress	15 psi	15 psi	100

h. Replacing the 75 lb rail with 115 lb rail has reduced tie and ballast stress, but they are still too high. As the DEH also notes that rail replacement is a very expensive action, another alternative is considered.

i. In the existing track, nearly all the ties are 6" x 8" in cross section, while standard commercial main line ties are 7" x 9" in cross section. A trial is then made keeping the existing 75-lb rail (and the proposed 6" additional ballast), but upgrading the ties to the larger cross section. Table C-3 shows the results.

Table C-3. Add 6" Ballast and Install 7" x 9" Ties.

	Stresses and Loads	Suggested Limits	% of Limit
Rail Bending Stress	17,800 psi	25,000 psi	71
Tie Reaction	20,500 lbs	14,200 lbs	87
Tie Bending Stress	1,470 psi	1,050 psi	106
Ballast Surface Stress	66 psi	61 psi	109
Subgrade Surface Stress	13 psi	15 psi	89

j. While tie bending and ballast surface stresses are still slightly over the suggested limits, table C-3 shows that installing 7" x 9" ties (instead of replacing the rail) has provided a more effective structural improvement to the track.

k. As a result of this analysis, the DEH decides to see about fitting the tie/ballast combination into the budget. This appears to be a good, cost-effective choice since, from a structural improvement perspective, it will accomplish more than the rail/ballast combination at much less expense.

l. In this case, though, even the tie/ballast combination turns out to be more than the current budget will allow, so the DEH considers the following: add the 6 inches of ballast this year, and as future budgets permit, begin replacing deteriorated ties with 7" x 9' ties. Though not obtainable immediately, over time this approach would appear to provide the kind of track needed to properly support the 140-ton flatcars. Further investigation into other factors and costs will be done before a final choice is made.

m. The example above was intended to demonstrate that with appropriate input to the TRACK program, and by knowing the relative costs of basic track work, the program can be used to indicate good, cost-effective alternatives for producing a track system with the required structural capability.

APPENDIX D
SAMPLE TRACK REHABILITATION REPORT

D-1. Sample Report.

This sample report illustrates the type of information, and level of detail, suggested for an analysis of a military railroad network, in preparation for rehabilitation work. The material which explains how the work is normally conducted is included for the benefit of the reader and would not be necessary in an actual rehabilitation plan.

a. Included in this example report are:

(1) A description of track and roadway condition.

(2) A problem/defect analysis.

(3) A sequential work plan to correct the defects.

(4) Cost estimates for each item of the work plan.

b. The material in appendix C covers the structural evaluation which is normally required in a rehabilitation plan. The operational evaluation (not detailed here) should follow the guidance in paragraph 5-5.

D-2. Railroad Track Rehabilitation Report for Fort Example Summary.

a. Examination of the railroad network at Fort Example showed the following major deficiencies:

(1) Inadequate lateral and longitudinal track stability.

(2) Deteriorated track through road crossings.

(3) Turnout defects.

(4) Washouts under track.
(5) Defective and/or skewed ties in certain areas.

(6) Loose or missing track fastenings.

(7) Thick vegetation growing in some portions of track.

b. The work plan was divided into 2 phases, with a total project cost of approximately \$970,000.

c. Phase 1 (to be accomplished first) covers the rehabilitation of the primary route and sidings extending from the connection with the commercial carrier to the end of the East Line. This work is estimated to cost approximately \$550,000.

d. Phase 2 covers rehabilitation of most of the remainder of the track network: the south half of the Main Line, the West Line, and the North Line. This work is estimated to cost approximately \$420,000.

e. The remedial work described in this report would restore the railroad network to a fully functional level, in a cost-effective manner. Remedial work has been specified only for those sections of track where the work is most needed. Tracks with no current use are not included in the plan.

f. The work plan has been designed so that when completed, the railroad network would require only normal routine maintenance to keep it fully functional for the foreseeable future.

**SAMPLE RAILROAD TRACK REHABIUTATION REPORT
FOR
FORT EXAMPLE**

Contents

	<i>Page</i>
1. INTRODUCTION	D-4
Background	D-4
Objective	D-4
Approach	D-4
Scope	D-5
2. OPERATIONAL EVALUATION.....	D-5
3. DESCRIPTION OF NETWORK AND TRACK CONDITION	D-5
Introduction	D-5
Rail	D-7
Plates/Fastenings.....	D-7
Ties.....	D-7
Ballast	D-7
Drainage/Subgrade	D-7
Vegetation	D-8
Turnouts	D-8
Road Crossings.....	D-8
Track Geometry.....	D-8
Bridges	D-8
4. STRUCTURAL EVALUATION (see app C).....	D-8
5. ANALYSIS OF MAJOR DEFICIENCIES.....	D-8
6. RECOMMENDATIONS AND COST ESTIMATES FOR REMEDIAL WORK.....	D-9
7. CONCLUSIONS AND RECOMMENDATIONS.....	D-15

List of Tables and Figures

Tables		
<i>Number</i>	<i>Title</i>	<i>Page</i>
1	Key to Track Names and Station Locations	D-7
2	Cost Estimate Summary	D-10
3	Road Crossing Repair/Rebuilding	D-11
4	Turnout Rehabilitation	D-13
5	Ballast and Surfacing Locations	D-14

Figures

<i>Number</i>	<i>Title</i>	<i>Page</i>
1	Installation Track Diagram	D-6

1. Introduction

Background

This rehabilitation plan was prompted by reports that portions of the For Example railroad network were in a general deteriorated condition and that results of the structural evaluation program indicated structural deficiencies in several stretches of track. These conditions were confirmed by the team performing the track assessment contained in this report.

Objectives

The objectives of this report are to:

- (1) Document the track and roadway deficiencies found during the recent field inspection, both by type and extent.
- (2) Propose corrective measures.
- (3) Provide cost estimates for budget planning.

The corrective work included in the plan is intended to restore the railroad network in a cost-effective manner. Thus, not all sections of track in the network are included in the plan, and each type of remedial work is specified only for those sections most in need. Further, corrective work is specified only to the extent which will restore the long term function of the track. Tie replacement estimates are based on improving tie condition to the point where installation trackage can function well for five years before the next tie replacement program is needed.

Approach

A 3-person team visited the installation to examine the railroad network. During this visit, all track (except the short piece leading to the old coal/gravel chute) was examined by walking inspection, and all primary routes were traveled

with the installation's 120-ton locomotive. In addition, those who were familiar with the track were interviewed about deficiencies they had observed and about track work performed in recent years.

Scope

This report is intended to assist in the preparation of contract specifications for remedial track work. Neither the field investigation nor this report is intended to cover every detail required for proper restoration of the railroad network, nor is this report intended to be a substitute for a complete statement of work and specifications. There are, in fact, several items noted that will require additional examination and decisions before a complete and final remedial work plan can be established.

Accompanying this report are both general and detailed track maps and photographs (with notes)

showing portions of the railroad network and representative defects.

2. Operational Evaluation

This topic should be covered according to the guidance in paragraph 5-5.

3. Description of Network and Track Condition.

Introduction

The railroad network connects with the (Railroad Name) Railway about 10 miles east of (City, (State). Of the 19.95 miles of track, 9.62 miles are primary routes, 3.43 miles are in the classification yard, and 6.90 miles are loading and storage sidings and auxiliary tracks. A track diagram is shown in figure D-1, with a key to track designations in table D-1.

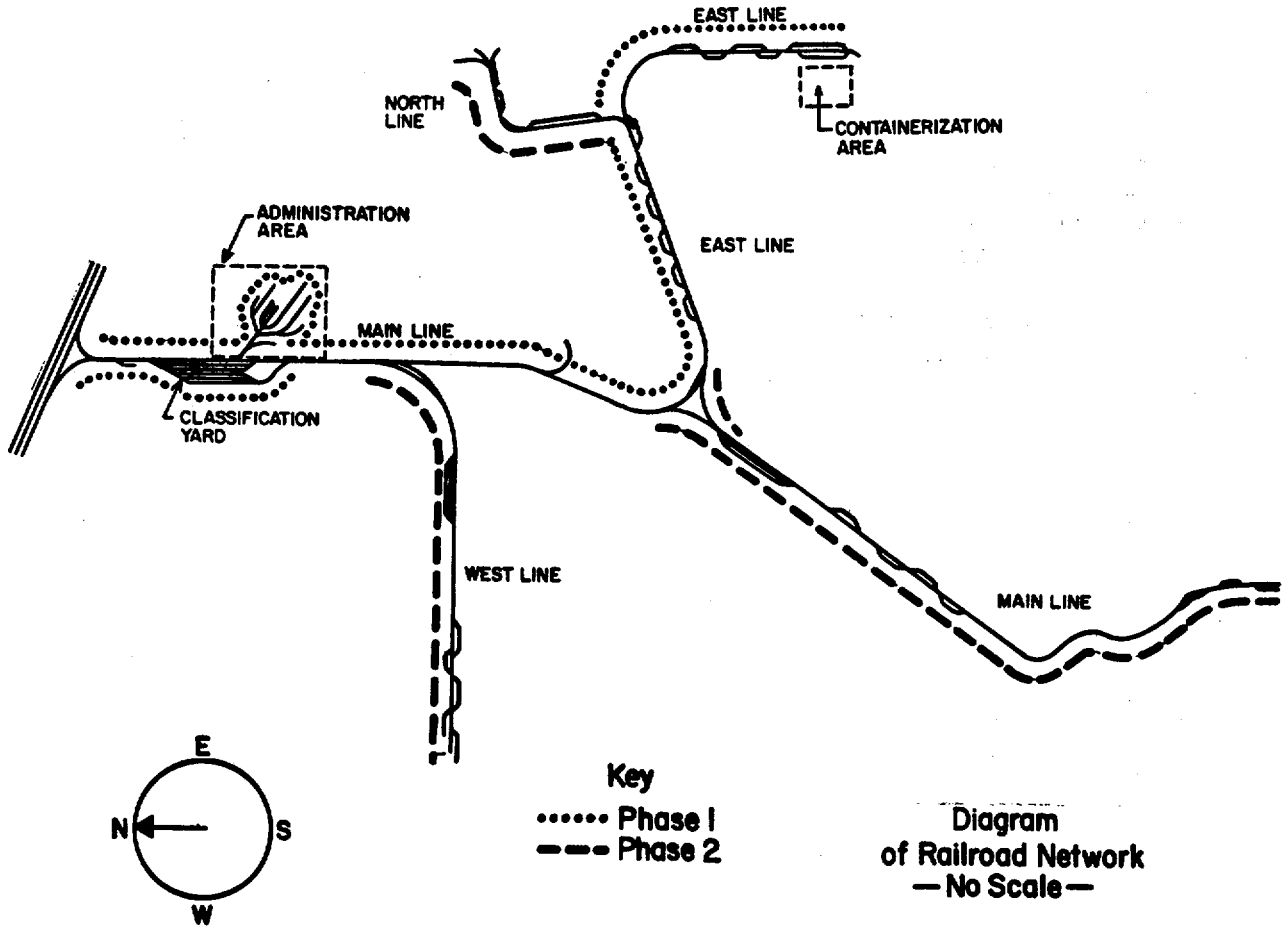

Figure D-1. Track Diagram for Fort Example.

Table D-1. Key to Track Names and Station Locations.

Letter Prefix	Track Type or Area
M	Main Line
E	East Line
W	West Line
N	North Line
A	Administration Area
P	Sidings serving loading ramps
S	Sidings serving buildings A through L
X	Miscellaneous spurs or sidings
Y	Wye tracks
2-14	Tracks in the Classification Yard.

Incoming cars are generally brought to the classification yard by the commercial carrier. There, one of the two installation locomotives will pick up the cars and deliver them to the appropriate area for loading or unloading. These cars are then brought back to the yard to be picked up by the commercial carrier. Below is a description of the railroad network, by component, reflecting conditions found during the investigation.

Rail

a. *Description:* 80% of the rail is 90 lb. (weight per yard of length) and manufactured between 1909 and 1924. The remaining 20% is 85 lb. The 85 lb. rail is primarily in Tracks 4 through 14 of the classification yard, the end of the North Line, and on Track A5 in the Administration Area (leading to the engine house). All rail was manufactured before the control cooling process was in use. (The control cooling process, now standard practice, greatly reduces the formation of internal defects.) b. *General Condition:* The rail is generally in good condition, neither excessively or unevenly worn. Very few pieces show serious end batter or surface bending. Likewise, obvious external defects, serious corrosion (except, perhaps in crossings-where the whole rail is not visible), and breaks are rare. (Testing for internal rail defects was not done.) **Plates /Fastenings**

a. *Plates:* Almost all track has single shoulder tie plates. These are in adequate condition, with relatively few missing or defective.

b. *Joints:* Joint bars are in good condition, with few excessively worn, cracked, or broken. However, many bolts are missing, loose, or not fully tightened. Of those that are not fully tightened, many appear to be rusted solid with the nut.

c. *Spikes:* Spikes are in good condition, however some are not fully driven or have worked their way up in the last few years. Also, spikes have

been frequently driven through angle bar base slots, which is no longer considered to be good practice.

d. *Anchors:* A portion of the primary routes have rail anchors. However, most of the anchors are far enough from the ties that they can provide no benefit in restraining longitudinal rail movement.

Ties

a. *Description:* Most older ties are 6" x 8" in cross section. Most of the ties installed during the tie replacement 8 years ago are 7" x 8".

b. *General Condition:* Tie condition is generally fair to good. Areas which did not receive ties during the last tie replacement program are generally in the worst condition.

On the Main Line, approximately between stations 200+00 and 250+00, there are many skewed, bunched, or otherwise misspaced ties.

Ballast

a. *Description:* Most track in the primary routes has ballast composed of a low density, finely crushed volcanic material or slag, or cinders mixed with earth. Some stretches of track appear to have no real ballast section, leaving the track essentially sitting directly on the subgrade.

During recent track work, some new ballast was applied. This ballast is crushed rock of about AREA 3 or 4 gradation and appears to be good, hard material. However, in most cases, this ballast is only a surface treatment, helping to fill in cribs (the spaces between the ties) and fill out the shoulders (at the ends of the ties).

b. *General Condition:* The cinder/volcanic/earth material seems to drain adequately, but apparently provides insufficient lateral or longitudinal stability to the track. (See Track Geometry section below.) Additionally, this material is not sufficiently dense and stable to resist washout from heavy rains. (See Drainage/Subgrade section below.)

Drainage /Subgrade

a. *Description:* While the rainfall in this area of the country is not high, much of the rain comes in short, heavy periods, resulting in flash floods and washouts. Culverts at the installation are generally large (as big as 72") and often of double pipe arrangement, not only to accommodate sudden heavy flows, but also the debris that is swept along by the water.

The track is built on a sandy subgrade, and is generally elevated above surrounding ground level. There are, however, clay layers near the surface in some locations.

The large, flat areas containing tracks in the classification yard and in the Administration Area do not have a subdrainage system.

b. General Condition: Drainage is generally good, both from the track and through culverts. However, there are a few problem areas. After a heavy rain, water commonly stands in the Administration Area and in some loading sidings for quite some time. Also, due to the large amount of debris present in the storm runoff, some culverts are partially or fully blocked.

Heavy rains have also caused several small washouts on the Main Line, especially along a roughly 800 foot stretch between stations 162+00 and 170+00 and at the south end of the line.

In some places, shallow clay seams block vertical drainage, but water can usually escape adequately in lateral directions. And despite the numerous loose joint bars, the number of low joints is quite small, indicating good vertical ballast and subgrade support.

Vegetation

a. Description: Thick brush and low vegetation grow close to the track in many stretches of track, especially in loading sidings and near the ends of the primary routes.

b. General Condition: Some vegetation is very tough, and where dense growth occurs, it scrapes the sides of trains. Because of this growth, it is difficult for a person to walk next to the track in several loading sidings and at the end of the Main Line.

Turnouts

a. Description: Turnouts are either 85 or 90 lb., matching the rail in the adjacent track. All but a few are number 8 (in size) and have bolted frogs and either 11' or 16'6" switch points.

b. General Condition: Overall, turnout condition, line, and surface are adequate. However, many switches are difficult to operate and badly need cleaning, lubrication, and adjustment. Also at many switches, the heel bolts are loose and the nuts and bolts often appear solidly rusted together, which would prevent re-tightening. Some switch points are also badly chipped or broken, and other miscellaneous parts need replacement.

About half the turnouts had most or all of their ties replaced during the last tie replacement program. A few turnouts that did not get new ties do need some new ones.

Road Crossings

a. Description: Most crossings are all asphalt, with a few gravel/dirt type. There are two rubber crossings through the Main Highway near the connection with the commercial carrier.

b. General Condition: About 25 percent of the asphalt crossings are in fair to poor condition. Likewise, the track in those crossings appears to be in fair to poor condition, typically showing loose joints and wide gage. Through a few crossings, only the slow and careful operation by the installation train crews has prevented derailments from occurring.

Track Geometry

a. Description: Track geometry describes the relative position of the two rails and track in the vertical and horizontal planes. The three primary measurements are:

- (1) Alignment-a measure of lateral track deviations.
- (2) Surface/Crosslevel-measures of vertical track deviations.
- (3) Gage-the spacing between the two rails. (Standard Gage is 56-1/2").

b. General Condition:

- (1) Alignment: Track alignment is generally fair, with some poor sections.
- (2) Surface/Crosslevel: Track surface is generally adequate, although poor in places on the east half of the East Line, west half of the West Line, and spots on the Main Line. Track surface is also poor in some loading sidings. A few curves have excessive superelevation.
- (3) Gage: Track gage is generally good, with the exception of some of the road crossings, where side gage is common, and spots where skewed ties have caused tight gage.

(3) Gage: Track gage is generally good, with the exception of some of the road crossings, where side gage is common, and spots where skewed ties have caused tight gage.

Bridges

a. Description: There are three all-timber bridges:

Line	Location	Length	Deck Type
Main	19+13	64 Feet	Open
West	9+02	85 Feet	Ballast
West	40+00	122 Feet	Open

b. General Condition: These bridges were thoroughly inspected about two years previously, and found to be in good condition. During this visit, the bridges were given a brief inspection, and no obvious defects were apparent.

4. Structural Analysis

See appendix C for coverage of this topic.

5. Analysis of Major Deficiencies

Below is a description of the major track deficiencies, along with contributing factors, where appropriate. In addition, these deficiencies are referenced to the remedial actions (as described in Chapter 4) which are designed to correct them.

Inadequate Lateral and Longitudinal Track Stability

The track at the installation has, at best, a surface layer of crushed rock ballast. Most stretches have a low density mix of fine crushed volcanic material and earth filling in the spaces between and around the ties. This material does not provide adequate lateral or longitudinal track support. And as a result, track alignment is generally fair or poor, and many ties have shifted position and become skewed (not perpendicular to the rails).

To both restore and keep proper track line and surface and maintain proper tie position, a sufficient amount of good quality ballast material must be added to the track. In addition, anchors must be correctly re-applied and added where needed. Remedial Actions 2, 6, 8, 9, 12, and 13 (as listed on page 16) are designed to establish adequate lateral and longitudinal track stability.

Deteriorated Track Through Road Crossings

About 25% of the asphalt crossings are in poor condition, and likewise, so is the track in them; ties have deteriorated, track support is mushy, and joints have loosened-in some cases allowing track gage to widen to an unsafe distance.

Remedial Action 5 includes complete crossing/track rebuild, as required.

Turnout Defects

The portion of the track covered by this rehabilitation plan includes 48 turnouts. Many of these are difficult to operate, out of adjustment, and have loose or defective parts. Remedial Action 9 (Restore Turnouts) includes allowances for general turnout rehabilitation.

Washouts Under the Track

Heavy rain runoff occasionally washes out ballast and subgrade beneath the track in three areas along the Main Line. Nine small washes have occurred in the last 3 years in the Main Line between Sta. 162+80 and 169+70. One small washout occurred near Sta. 253+40, and a deeper washout just past that point.

This is one area in which further study will be required to determine the most cost effective way to either eliminate the probability of future washouts, or at least minimize possible track damage.

Remedial Action 2 includes a general plan for correcting drainage problems at these washout areas.

Skewed Ties

Some areas of the Main Line (mostly between stations 200+00 and 250+00) have skewed (crooked), bunched, and misspaced ties.

This situation is caused by the following:

(1) Low density ballast which cannot resist tie movement.

(2) Cribs (space between the ties) not fully filled with ballast, further reducing resistance to tie movement.

(3) Anchors not replaced after tie installation, or applied to only one rail (one side of the tie).

(4) Track on grades. Portions of the track are on grades steep enough to encourage longitudinal rail movement, and thus also, tie movement.

(5) Spikes driven in the slots in angle bar type joint bars. This is no longer considered good practice. As joints are usually staggered, rarely does a tie ever have a joint on both rails. Driving spikes into the joint bar base slots will then have the same effect as anchoring only one side of a tie.

(6) Ties with incorrect spiking pattern, present in some of the older ties. (While this incorrect pattern does not actually cause tie skewing, it does encourage it.)

(7) Some ties appeared to have been installed crooked.

Remedial Action 7 provides for repositioning skewed and misspaced ties, and Remedial Action 10 will help prevent future tie movement.

Loose or Missing rack Fastenings

Numerous rail joints have loose or missing bolts, and several joints (at least 12 noted during the inspection) have both bolts in one rail missing.

Remedial Action 8 calls for tightening all joints and replacing defective bolts and joint bars.

Vegetation In or Near the Track

Scattered locations along primary routes and loading sidings have thick brush growing close to the track, and in some cases, in the ballast section. This vegetation must be removed before any track work can be performed.

In addition, sufficient herbicide needs to be applied soon after completion of track work to prevent future brush growth.

Remedial Actions 1 and 13 cover the removal and future prevention of brush growth.

6. Recommendations and Cost Estimates for Remedial Work

General

This section presents a general plan for correcting the majority of track deficiencies. The plan is organized as a list of 14 remedial actions, numbered in general work sequence order. The cost estimates for each remedial action are broken down between Phase 1 (to be done this year) and Phase 2 (to be done next year). A cost estimate summary is shown in Table 2.

Phase 1 and Phase 2 include the following trackage:
Phase 1

- Main Line from connection with the commercial carrier (Sta. 0+00) to East Junction (Sta. 119+81).
- Track Y1 and Classification Yard tracks 2-5.
- Administration Area tracks A1-A8.
- East Line and sidings from Origin (Sta. 0+00) to End (Sta. 120+56).

Phase 2

- Main Line and sidings from East Junction (Sta. 119+81) to End (Sta. 263+97), and track Y2.
- West Line and sidings from Origin. (Sta. 0+00) to End (Sta. 75+06).
- North Line and sidings from Origin (Sta. 0+00) to End (Sta. 47+96).

The work plan and estimates are for restoration of the majority of the railroad network. However, not all remedial actions are intended to be carried out on all trackage. Within the description of each remedial action, the intended work limits are listed, where appropriate. Generally not included in the work plan are Classification Yard tracks 6-14 (the far west tracks), tracks X1 through X5, Administration Area track A9 (to the old coal/gravel chute), and track P5 (at the end of the West Line). These tracks, while required for mobilization, are not in regular use.

Remedial Actions

A cost estimate summary of the remedial actions is shown in table D-2.

Table D-2. Cost Estimate Summary

REMEDIAL ACTION		PHASE 1	PHASE 2	TOTAL
No.	Description			
1	Remove Vegetation	\$1,200	\$2,400	\$3,600
2.	Restore Drainage	15,000	35,000	50,000
3	Rail Defect Inspection	5,000	-----	5,000
4	Replace Defective Rail	13,600	13,600	27,200
5	Rebuild Crossings	29,950	33,470	63,420
6	Tie Replacement	140,000	100,000	240,000
7	Respace Ties	3,250	8,125	11,375
8	Tighten Bolts/Spikes	18,700	18,700	37,400
9	Restore Turnouts	19,800	12,150	31,950
10	Rail Anchors	33,580	25,200	58,780
11	Unload Ballast	147,640	86,060	233,700
12	Surface Track	55,200	32,175	87,375
13	Herbicide Application	3,200	2,600	5,800
14	On-Site Inspection	12,000	12,000	24,000
	Subtotal	\$498,100	\$381,500	\$879,600
	10%	49,810	38,150	87,960
		547,910	419,650	\$967,560

NOTES

1. PHASE 1 covers the primary route from connection with the commercial carrier to the end of the East Line, Admin, Area, and Tracks 2—5 of the Classification Yard.
2. PHASE 2 covers the remainder of the Main Line (East Jct. To End), West Line, and North Line.

(1) *Remove Vegetation*

This should be the first step, to ensure that the track is fully accessible for other track work and that large amounts of vegetation will not be buried in the track during ballast unloading.

Vegetation removal can be accomplished with the plow and brooms of a ballast regulator, supplemented by laborers with brushcutters.

Phase	Mileage	\$ Estimate
1	1.2	1,200
2	2.4	2,400
Total	3.6 mi.	\$3,600

Note: Unit Cost = \$1,000/Mile

(2) *Restore Drainage*

It is essential that proper drainage be provided and maintained to prevent roadbed deterioration and track washouts. While drainage of the track network is mostly satisfactory, some general maintenance is needed, with a few areas that require serious attention.

This section provides a rough allowance for the following drainage work:

- (a) Excavator, dump trucks, backhoe, and laborers reshaping ditches and cleaning culverts.

- (b) Grading in the Administration area to keep water from standing within the roadbed.
- (c) Installation of culverts and related earthwork in washout areas on the Main Line.

Due to the nature of the drainage in the Administration Area and in the washout areas, it may not be practical to implement a solution which will entirely correct the problems. A plan which will greatly improve the situation may suffice.

Especially after heavy rains (such as were experienced last summer), water stands in the track in the Administration Area. Apparently, a drainage system was never installed here, and providing one now may be quite expensive.

It is recommended that consideration be given to at least providing some grading so that water will tend to flow away from the track into adjacent lowered areas. While this solution will not eliminate the standing water in this area, it could at least prevent it from standing in the track, where it would do the most damage.

In selected areas along the Main Line (especially between Sta. 162+80 and 169+70) ballast and subgrade have been washed out from beneath the track on several occasions. These areas are located in the natural drainage path of heavy rain runoff. While preventing all runoff from reaching the track may not be affordable, it is recommended that remedial work be considered which will at least prevent the water that does reach the track from causing any roadbed damage. Such work might include the following:

- (1) Install a culvert (perhaps double pipe) beneath the track, at the center of the washout area. Grade adjacent area to channel water through the culvert. Place large rock near the culvert approach to prevent erosion.
- (2) Construct an interceptor berm, or other obstacle, in the drainage path to break the force of a heavy runoff.
- (3) Increase the ballast shoulder in the washout areas to 12".

This may provide additional resistance against damage by water that does reach the track.

Any drainage work that may directly disturb the track should be accomplished before track work begins.

Phase	\$ Estimate
1	15,000
2	35,000
Total	\$50,000

(3) *Internal Rail Defect Inspection*

Since no record of internal rail defect inspection exists, and all rail was manufactured before the use of controlled cooling (1933), an inspection for the presence of internal rail defects should be made over the entire railroad network.

Phase	Mileage	\$ Estimate
1	17	5,000
2	-	-
Total	17 mi.	\$5,000

Note: Rail defect testing is priced per day plus travel costs, rather than by mileage. Phase 1 includes inspection of all track in the rehabilitation plan. In addition to cost effectiveness, inspection of all rail as soon as practical will permit an accurate determination of the quantity of rail that requires replacement.

(4) *Replace Defective Rail*

This estimate is an allowance for replacing the defective rails that may be found during an internal defect inspection.

Phase	Number of Rails	\$ Estimate
1	34	13,600
2	34	13,600
Total	68	\$27,200

Note: Unit Cost = \$400/rail. Estimate based on 33-foot sections of 90 lb. rail, and allowance of 4 defective rails/mile.

(5) *Rebuild Road Crossings*

In road crossings which require replacement, the track often needs to be completely rebuilt. In addition, conventional rail joints are often replaced with welded joints to eliminate the need for future joint maintenance (which usually requires tearing out at least part of the crossing surface). Welding joints in a crossing is especially recommended in areas with heavy truck traffic and in crossings in main running tracks. The rebuilding of crossings can start any time before the ballast and surfacing operations.

These estimates cover crossing replacements, as listed in table D-3. Three types are specified: complete track rebuild with timber/ asphalt surface, timber/asphalt surface replacement, and timber/gravel surface replacement.

Table D-3. Road Crossing Repair/Rebuilding.

Phase	Line	Centerline Location	Crossing Length	Rebuild Type
1	Main	24+53	24'	CA
		77+55	42'	CA
		113+65	87'	CA
	East	10+94	33'	A
		46+46	31'	A
		65+81	30'	CA

Table D-3. Road Crossing Repair Rebuilding-Continued.

Phase	Line	Centerline Location	Crossing Length	Rebuild Type
2	Main	173+20	25'	A
		193+31	22'	A
		204+20	15'	G
		258+09	30'	A
	West	4+45	18'	G
		37+56	21'	A
		45+49	19'	A
North	5+75	85'	CA	
	35+63	30'	A	
	44+95	67'	CA	

SUMMARY

Phase	Rebuild Type	Number of Xings	Footage	Number Welds
1	CA	4	183'	7
	A	2	64'	4
2	CA	2	152'	8
	A	6	126'	11
	G	2	33'	2

Rebuild Ape Key

CA-Timber/Asphalt crossing surface with complete track rebuild.

A--Timber/Asphalt crossing surface replacement.

G--Timber/Gravel crossing surface replacement.

The timber portion of the crossing surface refers to timber head boards installed along the gage side (or both sides) of the rail. Timber head boards help keep the flangeways clear, reduce intrusion of road material into the track, and lessen the lateral rail impact from vehicle traffic.

Phase	\$ Estimate
1	29,950
2	33,470
Total	\$63,400

Note: The following unit costs were used for crossing work:

- (1) Timber/Asphalt crossing with complete track rebuild, \$125/foot.
- (2) Timber/Asphalt crossing surface replacement, \$50/foot.
- (3) Timber/Gravel crossing surface replacement, \$25/foot.
- (4) Joint Welds, \$350 each.

(6) Tie Replacement

This estimate provides for ties primarily in the areas that were not covered in the previous tie replacement program. Generally, the limits are the same as specified for ballast and surfacing. The number of ties estimated is intended to allow the installation track to maintain sufficient tie condition for 5 more years before another tie program is required. (Although during the next 5

years, some spot tie replacement will probably be needed).

Included in the estimate for each phase is an allowance for 400 ties in the loading tracks (and the containerization terminal on the East Line to be done in Phase 1) and for 100 ties which drop during surfacing and are in too poor a condition to be respiked.

Exact tie counts should be made when preparing the final plans.

Phase	Numer of Ties	\$ Estimate
1	3500	140,000
2	2500	100,000
Total	6000	\$240,000

Notes: (1) Unit Cost estimate = \$40/Tie.

(2) The tie spacing at the installation averages 20', which equals 3,168 ties/mi.

(7) Respace Ties

During this remedial action, the many skewed and misspaced ties will be properly repositioned. This work also includes raising ties that dropped during the track raise and replacing occasional defective ties that cannot be re-spiked.

This estimate covers labor and machine costs for tie respacing.

Phase	Mileage	\$ Estimate
1	2.50	3,250
2	6.25	8,125
Total	8.75	\$11,375

Notes: (1) Unit Cost estimate = \$1,300/Mile.

(2) For Phase 2, tie respacing not required on Main Line from Sta. 154+00 to Sta. 200+00. This work is also only needed over approximately half of the North Line.

(8) Tighten and Replace Track Bolts/Drive High Spikes

Due to numerous loose rail joints, a bolt tightening machine should tighten all track bolts. During this operation, all defective bolts and joint bars should be replaced.

Along with bolt tightening, all high spikes should be driven down and all defective spikes replaced. This will minimize the number of ties that drop down when the track is raised during surfacing.

However, it is not recommended to either pull any spikes driven in the slots of angle bar type joint bars, or pull or add any spikes in ties with an incorrect spiking pattern. The combination of tie straightening/respacing, additional ballast, and application of rail anchors included in this rehabilitation plan should be sufficient to prevent any future tie movement due to incorrect spiking.

Further, there would be significant potential for

long term tie damage due to pulling spikes (even if old holes are plugged).

Both operations (for bolts and spikes) should be performed prior to any ballast unloading or surfacing.

Table D-4 provides a detailed listing of turnouts included in Phases 1 and 2, along with a rough approximation of switch tie requirements and switch point replacements. (Exact requirements should be determined for inclusion in contract work statement).

Phase	Mileage	\$ Estimate
1	8.5	18,700
2	8.5	18,700
Total	17.0 mi.	\$37,400

Phase	Number of Turnouts	\$ Estimate
1	10	19,800
2	12	12,150
Total	22	\$31,950

Note: Unit Cost estimate of \$2,200/Mile based on:

- (1) Bolt tightening, \$1,500/mi.
- (2) Allowance for extra bolts, \$2.50 each, 120 per mi, or \$300/mi.
- (3) Allowance for extra spikes and miscellaneous work, spikes @ \$1.00 each, total allowance @ \$400/mL

(9) Restore Turnouts

This work includes: surfacing turnouts; replacing defective parts; grinding switch points and frogs as needed; and cleaning, adjustment, and lubrication.

Notes: (1) Unit Cost varies with work required. Estimates based on:

- (a) \$1050/turnout for surfacing, miscellaneous parts, and cleaning and adjustment.
- (b) \$50/switch tie, installed.
- (2) Estimate allows for 75 switch ties in Phase 1 and 126 in Phase 2. (See Table 4).
- (3) Estimate allows for 7 switch points to be replaced in Phase 1 and 6 in Phase 2. Cost per point (installed) is estimated to be about \$800 for a 16'6" point.

Table D-4. Turnout Rehabilitation

Phase	Line	I.D. Number	Location	Direction	Switch Tie Requirement	(1) Point Replacement	
1	MAIN	M03	24+67	RIGHT	8	L R	
		M04	39+88	LEFT	-	R	
		M05	40+21	LEFT	-	LR	
		M07	44+84	LEFT	12	-	
	EAST	E03	3+64	LEFT	10	-	
		E04	14+49	LEFT	8	-	
		E08	36+15	RIGHT	20	-	
		E10	42+77	LEFT	8	-	
		E12	49+60	RIGHT	8	-	
		E17	117+95	LEFT	-	LR	
						<u>74</u>	<u>7</u>
	2	MAIN	M13	134+51	RIGHT	15	-
			M15	155+02	LEFT	5	-
M16			162+11	LEFT	5	-	
M17			170+55	RIGHT	9	L R	
WEST		W09	69+23	RIGHT	8	L	
		W11	70+89	LEFT	8	-	
		W12	71+54	RIGHT	8	R	
NORTH		NO1	8+78	RIGHT	12	-	
		NO4	23+03	LEFR	22	L	
		NO5	25+80	RIGHT	11	L	
		NO6 (2)	32+47	LEFT	9	-	
		NO7 (3)	32+87	RIGHT	14	-	
					<u>126</u>	<u>6</u>	

- Notes: (1) L = Left Point, R = Right Point
 (2) One switch rod missing
 (3) Cracked frog

(10) *Apply Rail Anchors*

After new ties have been installed and skewed and misspaced ties properly repositioned, rail anchors should be applied.

This estimate calls for every 5th tie to be box anchored (have 4 anchors applied), with anchoring of primary routes only (no sidings). See Notes 2 and 3 below for intended anchoring limits.

Phase	Mileage	\$ Estimate
1	4.77	33,580
2	3.58	25,200
Total	8.35 mi.	\$58,780

Notes: (1) Unit cost estimate of \$7,040/Mile, based on:

- (a) Purchase cost of \$2.00/anchor.
- (b) Installation cost of \$1.25/anchor.
- (c) 2,560 anchors/mi.
- (d) Assumption that 25% of required anchors can be salvaged from existing material.

- (2) For Phase 1, anchors are to be applied along the Main Line from Railroad connection (Sta. 0+00) to East Junction (Sta. 119+81); East Line from Origin (Sta. 0+00) to End (Sta. 120+56); and along Y1.
- (3) For Phase 2, anchors are to be applied along the Main Line from East Junction (Sta. 119+81) through Sta. -194+00; West Line from Origin (Sta. 0+00) through Sta. 70+89; and North Line from Origin (Sta. 0+00) through Sta. 43+63.
- (4) Anchoring near the two open deck bridges (M 19+13 and W 40+00) should be done as follows: no anchors on track on the bridge; box anchor every 3rd tie for 2 rail lengths (about 66 feet) off either end of the bridge.

(11) *Unload Ballast*

Once the track is clear of excess vegetation, all bolts in place and tight, high spikes driven, and track in crossings rebuilt, the track is ready for new ballast to be applied. Ballast and surfacing locations are shown in table D-5.

Table D-5. Ballast and Surfacing Locations

Location	Footage
Phase 1	
<i>Main</i>	
3+87 (S. end Rt. 40 Xing) to 19+13 (N. end bridge)	1,526
24+65 (S. end new Xing) to 45+50 (N. end scale track)	2,085
47+51 (s. end scale track) to 119+81 (east Junction)	7,230
	<u>10,841</u>
<i>East</i>	
0+00 (East Junction) to 120+56 (End)	12,056
Sidings (except X3, X4)	6,586
	<u>18,642</u>
<i>Yard</i>	
Tracks 2-5	5,823
<i>Admin</i>	
Track A1-up to 5+61 (Building 9)	561
Track A5-up to 14+40 (to engine house)	1,440
Track A6-up to 9+52 (end)	952
Track A--up to 6+00 (to scrap bin)	600
	<u>3,553</u>
Total Phase 1 Footage (7.36 mi.)	<u>38,859</u>
Phase 2	
<i>Main</i>	
119+81 (East Junction) to 194+01	7,420
257+79 to 263+97 (End)	618
	<u>8,038</u>
<i>West</i>	
0+00 to 75+06 (End)	7,506
<i>North</i>	
0+00 to 48+73	4,873
Tracks SASE	2,237
	<u>7,110</u>
Total Phase 2 Footage (4.29mi.)	<u>22,654</u>

This estimate is for sufficient ballast to give the track a 3-inch raise, fill in shoulders and cribs, and pull up any track sags. It includes the costs of purchasing the ballast material, delivery to the work site, and distribution along the track.

The mileages indicated correspond to the surfacing footages, as shown in table D5.

Phase	Quantity	Mileage	\$ Estimate
1	10,100 tons	7.36	147,640
2	5,900	4.29	86,060
Total	16,000 tons	11.65 mi.	\$233,700

Notes: (1) Unit Cost estimate of \$20,060/Mile based on:

- (a) Ballast quantity of 0.2 cu. yd per track foot (1,056 cu. yds/mi.) @ \$10.00/cu. yd. delivered to site, or \$10,560/mi.
- (b) Unloading operation @ \$9,500/mile.
- (2) Locations for ballast unloading are the same as for surfacing (Remedial Action 7).
- (3) 1 cubic yard of ballast weighs approximately 1.3 tons.
- (4) Ballast needed for rebuilding track in crossings is included in the estimate for rebuilding road crossings.
- (5) Estimate includes AREA standard 15% allowance for ballast waste and loss.
- (12) Surface Track/Reshape Ballast Section The main surfacing operation includes:
 - (a) Lifting the track 3 inches.
 - (b) Restoring proper track line and surface.
 - (c) Reshaping the ballast section.

The limits for this work are as shown in table D-5.

During the final design process the sidings serving the loading docks and magazine standards should be checked to ensure that there is proper horizontal and vertical clearance between the track and the loading platform. Any corrections that are required should be done during track surfacing.

Phase	Mileage	\$ Estimate
1	7.36	55,200
2	4.29	32,175
Total	11.65 mi.	\$87,375

Notes: (1) The Unit Cost estimate for surfacing is \$10,560/Mile. Included in this cost is the following work:

- (a) Raising the track 3".
- (b) Plowing new ballast back into the track to fill in up to the tops of the ties.
- (c) Reshaping the ballast section.
- (d) Sweeping the track.
- (2) For Phase 1, estimate assumes no track raise through the track scale, and also assumes that track will be raised to level of existing crossings in the sidings along the East Line (Buildings A-F).

- (3) For Phase 2, a 12' shoulder should be provided in the track washout areas along the Main Line.

(13) Herbicide Application

Once the track work is complete, all track should be sprayed to prevent the growth of weeds in the ballast section.

While vegetation spraying should be done at least once per year, this estimate is for one initial heavy application over a 16-foot wide path (8 feet from the center line of track on both sides).

Phase	Mileage	\$ Estimate
1	10.7	3,200
2	8.5	2,600
Total	19.2 mi.	\$5,800

Notes. (1) Contract herbicide application is priced per day. As a rough estimate, a unit cost of \$300/Mile was used.

- (2) Phase 1 to include all Classification Yard tracks.

(14) Quality Control Inspection

Although listed last, quality control inspection is an essential element for a successful track rehabilitation. It is an effective means of assuring that all work reflects good workmanship and is performed according to the contract specifications.

Phase	\$ Estimate
1	12,000
2	12,000
Total	\$24,000

Notes. (1) Inspection cost estimate based on \$35/Hour basic labor and overhead charge, or \$280/Day, and \$100/Day subsistence expenses. Total = \$380/Day.

- (2) Allowance for travel to and from site of one round trip/week = \$500.
- (3) Total Inspection Cost/Week = \$2,400.
- (4) Phase 1 and 2 estimated to require 5 weeks each of on-site inspection

7. Conclusions and recommendations

Proper track restoration will involve remedial work which requires special attention. It is essential that this work be done by skilled workers, with knowledgeable and attentive supervision.

As indicated in the report, there are still some areas that need further examination before detailed contract specifications can be made, particularly in the improvement of drainage in areas where track washouts have occurred. These additional determinations should be included as part of the final design process.

If the design work is to be contracted to an outside organization, it is recommended that a single design/inspection package be considered. Having the track work designed and inspected by the same organization has great potential for

improved quality control and accountability throughout the project.

To further clarify the work plan and contract specifications, the work requirements (by type and location) should be marked in the field, whenever practical. This might include: marking with paint

lose switch ties which need replacement, setting flags or stakes to indicate the limits where extra shoulder ballast is required, painting a code at each road crossing to indicate which type of reconstruction is to be done, and any other indicators which may help guide the field work.

The proponent agency of this publication is the Office of the Chief of Engineers, United States Army. Users are invited to send comments and suggested improvements on DA form 2028 (Recommended Changes to Publications and Blank Forms) to HQUSACE (CEMP-EA), WASH DC 20314-1000.

By Order of the Secretaries of the Army and the Air Force:

Official:

YVONNE M. HARRISON
*Administrative Assistant to the
Secretary of the Army*

DENNIS J. REIMER
*General, United States Army
Chief of Staff*

OFFICIAL

EUGENE A. LUPIA
*Maj General, USAF
The Civil Engineer*

Distribution:

Army: lb be distributed in accordance with DA Form 12-34-E, block 0777 requirements for TM 5-850-2.

Air Force: F

RECOMMENDED CHANGES TO EQUIPMENT TECHNICAL PUBLICATIONS



SOMETHING WRONG WITH THIS PUBLICATION?

THEN... JOT DOWN THE DOPE ABOUT IT ON THIS FORM, CAREFULLY TEAR IT OUT, FOLD IT AND DROP IT IN THE MAIL!

FROM: (PRINT YOUR UNIT'S COMPLETE ADDRESS)

DATE SENT

PUBLICATION NUMBER

PUBLICATION DATE

PUBLICATION TITLE

BE EXACT... PIN-POINT WHERE IT IS

PAGE NO.

PARA-GRAPH

FIGURE NO.

TABLE NO.

IN THIS SPACE TELL WHAT IS WRONG AND WHAT SHOULD BE DONE ABOUT IT:

TEAR ALONG PERFORATED LINE

PRINTED NAME, GRADE OR TITLE, AND TELEPHONE NUMBER

SIGN HERE:

DA FORM 2028-2
1 JUL 78

PREVIOUS EDITIONS ARE OBSOLETE.

P.S.—IF YOUR OUTFIT WANTS TO KNOW ABOUT YOUR RECOMMENDATION MAKE A CARBON COPY OF THIS AND GIVE IT TO YOUR HEADQUARTERS.

